

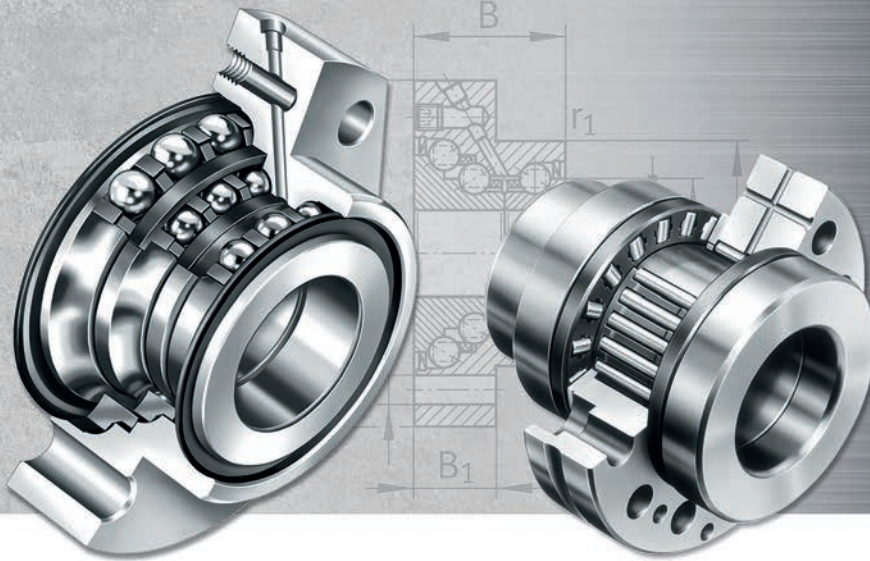

FAG



Bearings for Screw Drives

Axial angular contact ball bearings
Needle roller/axial cylindrical roller bearings
Accessories

SCHAEFFLER

Foreword

Focus on complete system

With trend-setting bearing arrangement solutions for feed spindles, main spindles, rotary tables and linear guidance units, Schaeffler has been at the forefront of the world market for decades.

However, bearing components alone are often no longer the decisive factor for the success of these machine subsystems.

Indeed, our customers are continuing to benefit directly from significant performance improvements and unique selling points thanks to our “ready-to-fit” products, since these follow the efficient basic concept: unpack, screw mount, use. In order to optimise the entire machine tool system, however, it is also becoming ever more important to integrate important functions such as measurement, sealing, lubrication, braking etc. in the components themselves. This intellectual approach focusses consistently on the complete system, including the bearing and bearing position. This means that you can access a product range that gives optimum coverage for all your applications in the machine tool.

Direct drives and mechatronic solutions

In addition, there is increasingly frequent usage of direct drives and mechatronic solutions in machine tools. We therefore have IDAM – INA-Drives & Mechatronics – as a further strong partner in our provider network. In this way, we can supply you from a single source with not only bearing elements but also components precisely matched to the drive system.

This opens up completely new technical and economic design possibilities for your requirements as well as significant advantages in the time and process chain.

In terms of products, we can offer you a comprehensive, precisely balanced range, precision technology and top product quality. In order to match the pulse of your developments as closely as possible, we also have a worldwide network of engineers and service and sales technicians working for you and ensuring that we maintain close contact with you in your own location.

We are therefore confident that we have the right product for you, from a robust individual component right through to the defining high end system solution.

Bearings for screw drives

Matrix for preselection of bearings	4
--------------------------------------------	---

The application-oriented matrix allows rapid preselection of the suitable bearing.

Axial angular contact ball bearings	6
--------------------------------------------	---

Axial angular contact ball bearings are precision bearings for screw drive bearing arrangements. Depending on the series, they can support radial forces as well as axial forces in one or both directions. Contact seals protect the rolling element system against contamination and moisture. For higher speeds, minimal gap seals can be used.

The bearings are available with and without fixing holes in the outer ring. Bearings with holes are screw mounted directly on the adjacent construction. This solution is particularly economical since there is then no need for the locating bore that would otherwise be required or for the bearing cover with the associated matching work.

For some areas of application, a bearing arrangement of lower precision is often sufficient. For this purpose, bearings with less stringent tolerances are available.

Needle roller/axial cylindrical roller bearings	100
--------------------------------------------------------	-----

These precision bearings are double direction axial cylindrical roller bearings with a radial bearing component.

The bearings are available with and without fixing holes in the outer ring. Bearings with holes are screw mounted directly on the adjacent construction. The large contact surface and the small pitch of the holes allows a connection to the adjacent construction that is extremely rigid and with low tendency to settling. There is therefore no need for the bearing cover that would otherwise be required to hold the bearing, and the matching work required.

If the axial abutment of the shaft locating washer is not sufficient or a seal raceway is required, bearings with a stepped shaft locating washer extended on one side are suitable.

Accessories	134
--------------------	-----

Seal carrier assemblies	
Precision locknuts	
Sockets	
BEARINX-online Easy BallScrew	

Seal carrier assemblies DRS are complete sealing sets that are screw mounted on the outer ring of needle roller/axial cylindrical roller bearings ZARF(L). They are precisely centred in this position and seal the bearings against external influences.

Precision locknuts are used to achieve a defined axial preload in bearings for screw drives. They are also used where high axial forces must be supported and high axial runout accuracy and rigidity are required.

Calculations on screw drive bearing arrangements can be carried out free of charge using BEARINX-online Easy BallScrew.



ZKLF

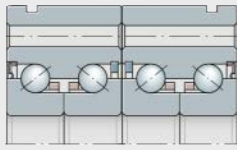

ZKLF..-2RS-2AP

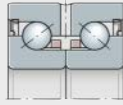

ZKLN



ZKLN..-2RS-2AP



7602, 7603,
BSB

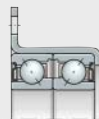

ZKLR

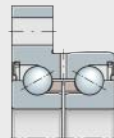

ZKLFA

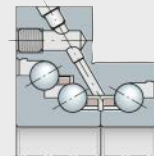

DKLFA

0008292A

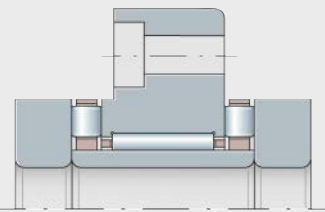

ZARF

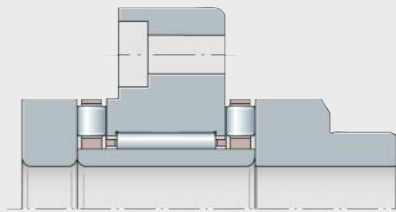

ZARF..-L

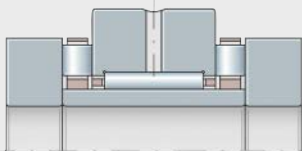

ZARN

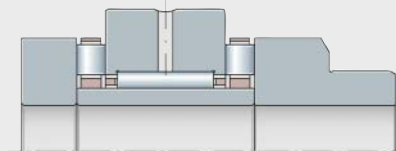

ZARN..-L

00082935

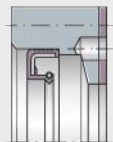

DRS

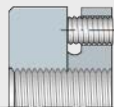

AM



ZM

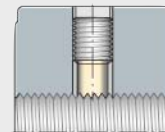

ZMA



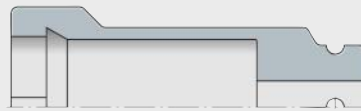

AMS



LOCKNUT-SOCKET-KM

00086074

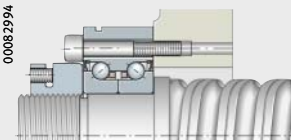
Matrix for preselection of bearings

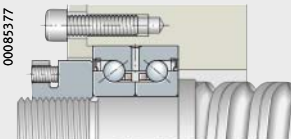
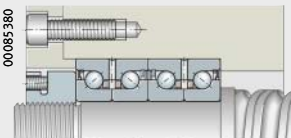
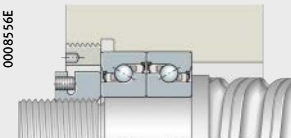
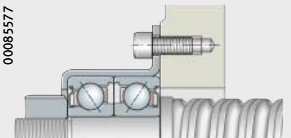
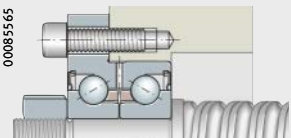
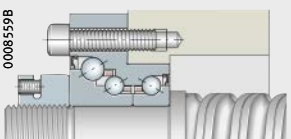
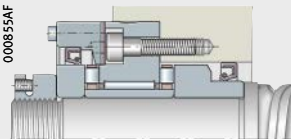
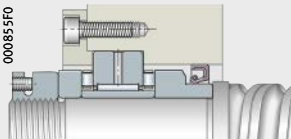
Application	Series	
For standard applications	 <p>00082994</p>	<p>ZKLF..-2Z ZKLF..-2RS ZKLF..-2RS-PE</p>
	 <p>00083FOC</p>	<p>ZKLF..-2RS-2AP</p>
	 <p>00085377</p>	<p>ZKLN..-2Z ZKLN..-2RS ZKLN..-2RS-PE</p>
	 <p>00085380</p>	<p>ZKLN..-2RS-2AP</p>
	 <p>0008556E</p>	<p>7602 7602..-2RS 7603 7603..-2RS BSB BSB..-2RS</p>
For special applications	 <p>00085577</p>	<p>ZKLR..-2Z ZKLR..-2RS</p>
	 <p>00085565</p>	<p>ZKLFA..-2Z ZKLFA..-2RS</p>
	 <p>0008559B</p>	<p>DKLFA..-2RS</p>
For applications requiring very high accuracy and rigidity	 <p>000855AF</p>	<p>ZARF ZARF..-L</p>
	 <p>000855FO</p>	<p>ZARN ZARN..-L</p>

Definition of symbols

- +++ Very good
- ++ Good
- + Satisfactory
- Adequate

Attention!

This selection matrix is a general overview for preliminary assessment of whether bearings can be considered for the required purpose. For the specific application, the data in the product sections and the technical principles must always be taken into consideration.

Features	Characteristics					Description, page
	High radial runout accuracy	High speeds and low friction	High rigidity and load carrying capacity	Work on adjacent construction and mounting	Low lubricant consumption	
<ul style="list-style-type: none"> ■ Outer ring for flange mounting ■ Gap seals or contact seals on both sides ■ Greased, with relubrication facility ■ Most economical type of screw drive bearing arrangement 	++ ++ +	+++ ++ ++	+ + +	+++ +++ +++	++ ++ ++	13
<ul style="list-style-type: none"> ■ As ZKLF, but in matched pair ■ Significantly higher load carrying capacity and rigidity than ZKLF 	++	++	++	++	++	15
<ul style="list-style-type: none"> ■ Gap seals or contact seals on both sides ■ Greased, with relubrication facility ■ Easier mounting than single row bearings, e.g. for plummer block housings 	++ ++ +	+++ ++ ++	+ + +	+ + +	++ ++ ++	16
<ul style="list-style-type: none"> ■ As ZKLN, but in matched pair ■ Significantly higher load carrying capacity and rigidity than ZKLN 	++	++	++	+	++	17
<ul style="list-style-type: none"> ■ Open or sealed on both sides ■ Highly suitable for mounting in pairs to form wide range of contact angle combinations 	++ ++ ++ ++ ++	+++ ++ +++ ++ +++ ++	+ + + + +	- - - - -	++ ++ ++ ++ ++	20
<ul style="list-style-type: none"> ■ Particularly economical alternative to solutions comprising individual ball bearings ■ Gap seals or contact seals on both sides ■ For applications with comparatively low loads, but high positional accuracy 	+ +	+++ ++	- -	+++ +++	++ ++	22
<ul style="list-style-type: none"> ■ Outer ring for flange mounting ■ Stepped outer ring with flattened areas on both sides ■ Gap seals or contact seals on both sides 	++ ++	+++ ++	+ +	+++ +++	++ ++	24
<ul style="list-style-type: none"> ■ Higher load carrying capacity on one side ■ Outer ring for flange mounting ■ Sealed on both sides ■ For vertical axes ■ For locating bearing arrangements on both sides 	+	++	++	+++	++	24
<ul style="list-style-type: none"> ■ Outer ring for flange mounting ■ Very high accuracy, rigidity and load carrying capacity ■ Bearing prepared for sealing 	+++	+	+++	+	-	103
<ul style="list-style-type: none"> ■ Very high accuracy, rigidity and load carrying capacity ■ Bearing prepared for sealing 	+++	+	+++	-	-	104



FAG



Axial angular contact ball bearings

Axial angular contact ball bearings

	Page
Product overview	Axial angular contact ball bearings 8
Features	Single row and multiple row designs 10
	X-life 12
	Double row design, with fixing holes 13
	Double row design, without fixing holes 16
	Hybrid design HC 18
	Single row design, suitable for any combination 20
	Angular contact ball bearing unit, with fixing holes 22
	Double row design, with flange, with fixing holes 24
	Triple row design, with flange, with fixing holes 24
	Operating temperature 26
	Cages 26
	Suffixes 26
	Structure and meaning of designations 27
Design and safety guidelines	Basic rating life 29
	Static load safety factor 29
	Resultant and equivalent bearing load 30
	Maximum radial load on screw connections for ZKLF 38
	Permissible static axial load for ZKLF 39
	Design of screw drive bearing arrangements 39
	Design of a locating/locating bearing arrangement 44
	Design of adjacent construction 47
	Speeds 51
	Friction 52
	Lubrication 53
	Mounting guidelines 54
	Calculation example 58
Dimension tables	Axial angular contact ball bearings
	With fixing holes 66
	With fixing holes, less stringent tolerances 74
	With fixing holes, matched pair 76
	Without fixing holes 78
	Without fixing holes, less stringent tolerances 82
	Without fixing holes, matched pair 84
	Single direction, open 86
	Single direction, sealed on both sides 90
	Angular contact ball bearing units, with fixing holes 92
	Double row axial angular contact ball bearings with flange, with fixing holes 94
	Triple row axial angular contact ball bearings with flange, with fixing holes 98



Product overview Axial angular contact ball bearings

**Double row design,
with fixing holes**

Lip seals or minimal gap seals

ZKLF..-2RS, ZKLF..-2Z,
ZKLF..-2RS-PE

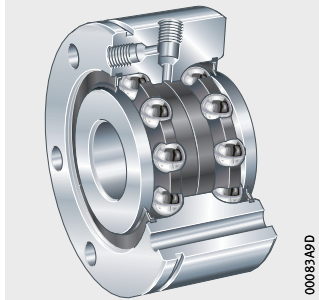

Matched pair design

ZKLF..-2RS-2AP

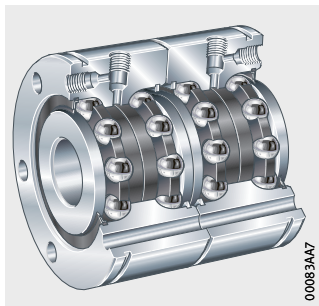

**Double row design,
without fixing holes**

Lip seals or minimal gap seals

ZKLN..-2RS, ZKLN..-2Z,
ZKLN..-2RS-PE

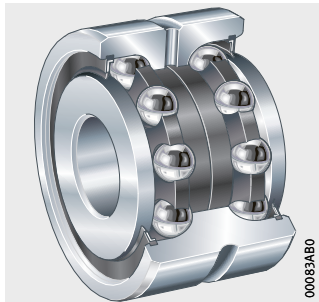

Matched pair design

ZKLN..-2RS-2AP

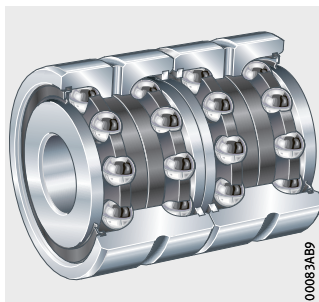

**Single row design,
for any combination**

With or without seals

7602, 7603,
BSB, BSB..-SU

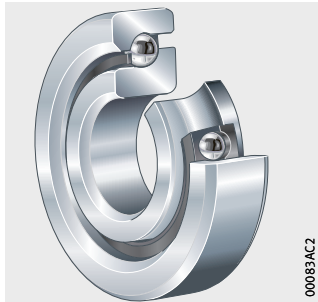

00083AC2

7602..-2RS, 7603..-2RS,
BSB..-2RS, BSB..-2Z-SU

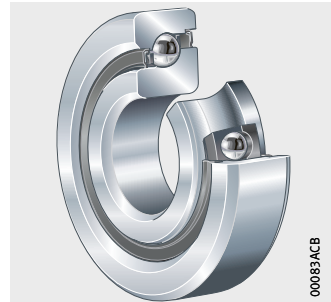

00083ACB



**Angular contact ball
bearing unit,
with fixing holes**

Lip seals or gap seals

ZKLR..-2RS, ZKLR..-2Z

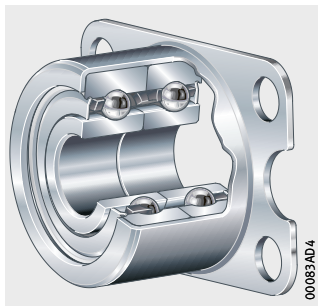

00083AD4

**Double row or
triple row design,
flange with flattened areas,
with fixing holes**

Double row design,
lip seals or minimal gap seals

ZKLFA..-2RS, ZKLFA..-2Z

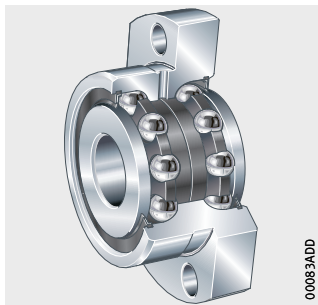

00083ADD

**Triple row design,
lip seals**

DKLFA..-2RS

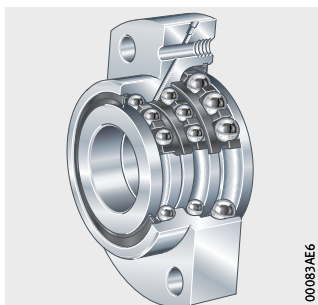

00083AE6

Axial angular contact ball bearings

Features Screw drive bearing arrangements are subjected to requirements that often cannot be optimally fulfilled by the design construction of conventional bearings.

For the design of bearing arrangements that have high accuracy, high load carrying capacity, high rigidity, low friction, are easy to fit and maintenance-free or low-maintenance and are suitable for the highly dynamic operating conditions of threaded spindles, there is a wide range of INA and FAG axial angular contact ball bearings. With this product range, solutions can be found to all the technical and economic demands placed on the bearing arrangements of screw drives.

Single row and multiple row designs

Axial angular contact ball bearings are available as single, double or triple row ready-to-fit units. They are self-retaining and comprise thick-walled, geometrically stable outer rings, ball and cage assemblies and one-piece or two-piece inner rings. In several series, the outer ring has through holes for simple flange mounting to the adjacent construction.

The bearing rings are matched to each other such that a defined preload is achieved when the rings are clamped in place using a precision locknut.

Axial and radial load capacity

Due to the 60° contact angle, the bearings can support high axial forces as well as radial forces.

Contact angle arrangement in X and O arrangements

In arrangements of multiple row angular contact ball bearings, a distinction is made between O, X and tandem arrangements in relation to the arrangement of contact angles. The arrangement of contact angles has an essential influence on the tilting rigidity of the bearing position, *Figure 1*, page 11, and *Figure 2*, page 11.

The characteristics of the O arrangement are:

- high tilting rigidity
- higher critical whirling speed of the threaded spindle due to the high tilting rigidity of the bearing position
- longer rating life under additional radial loads due, for example, to a belt drive

The characteristics of the X arrangement are:

- low tilting rigidity
- lower critical whirling speed of the threaded spindle
- shorter rating life under additional radial loads due, for example, to a belt drive.

Calculation example with BSB3062-SU
 $n = 500 \text{ min}^{-1}$

L_h = basic rating life
 ψ = misalignment

- ① X arrangement
- ② O arrangement

Figure 1
 Identical rating life of bearings
 in X and O arrangement
 with misalignments between
 bearing seat and threaded spindle

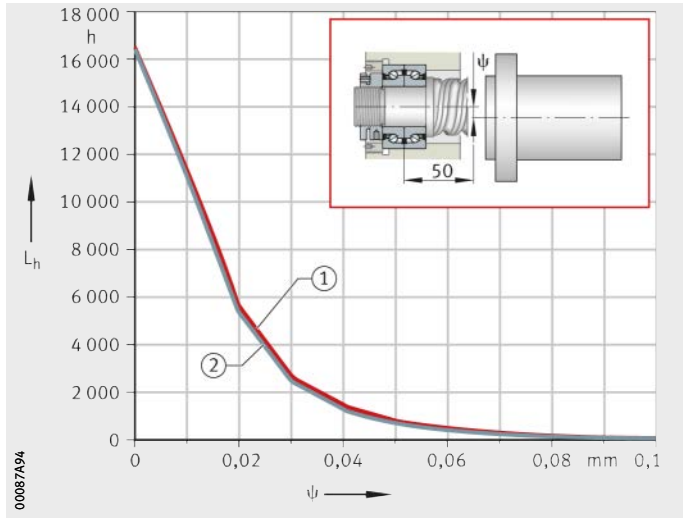

Calculation example with BSB3062-SU
 $n = 500 \text{ min}^{-1}$

L_h = basic rating life
 F_y = additional radial load due to belt drive

- ① X arrangement
- ② O arrangement

Figure 2
 Longer rating life of bearings
 in O arrangement
 with additional radial loads

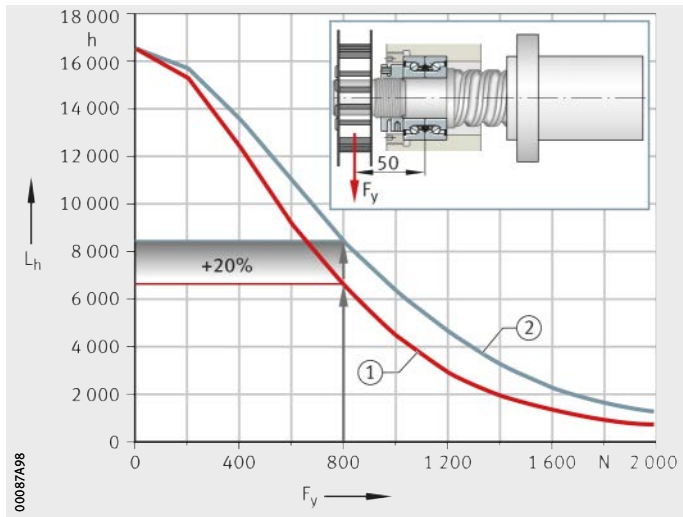

Axial angular contact ball bearings

X-life

Axial angular contact ball bearings ZKLF and ZKLN are supplied in the X-life design.

As a result of increased raceway accuracy and raceway quality, there is a significant reduction in the stress conditions present on the rolling elements and raceway under the same load, compared to the standard bearings. The improved quality gives reduced friction in the bearing and lower bearing temperatures; running resistance is lower, less strain is placed on the lubricant and the grease operating life and, where applicable, necessary relubrication intervals are extended. As a result of the lower frictional energy, there is a simultaneous increase in the energy efficiency of the bearing arrangement.

Higher basic load ratings and limiting speeds with X-life

The basic dynamic load ratings C_a of axial angular contact ball bearings in the X-life design are 10% higher than those of the previous standard designs. This leads to a longer rating life L_{10} or can be used to allow higher loads on the bearing arrangement while achieving the same rating life.

The lower bearing friction and associated reduction in heat generation in the bearing permit significantly higher limiting speeds $n_{G \text{ grease}}$.

Further information

- Reprint SSD 32, Bearings for Screw Drives in X-life Quality
- Download and ordering: <http://medien.schaeffler.de>.

**Double row design,
with fixing holes**

Axial angular contact ball bearings ZKLF are screw mounted directly on the adjacent construction or in a locating bore, *Figure 3* and *Figure 4*.

When axial angular contact ball bearings ZKLF are mounted without radial centring, *Figure 3*, the bearing is aligned in a radial direction using linear guidance systems and screw drive as a datum.

This prevents misalignments between the screw drive and bearing position. As a result, constraining forces that reduce the rating life cannot occur.

For easier dismounting of the bearings from a locating bore, the outer ring has a circumferential extraction slot, *Figure 4*.

Relubrication is facilitated by radial and axial threaded connectors with detachable grub screws.



ZKLF..-2RS
ZKLF..-ZZ
ZKLF..-2RS-PE

① Locknut

Figure 3

Outer ring screw mounted on flat adjacent construction, preloaded by locknut AM

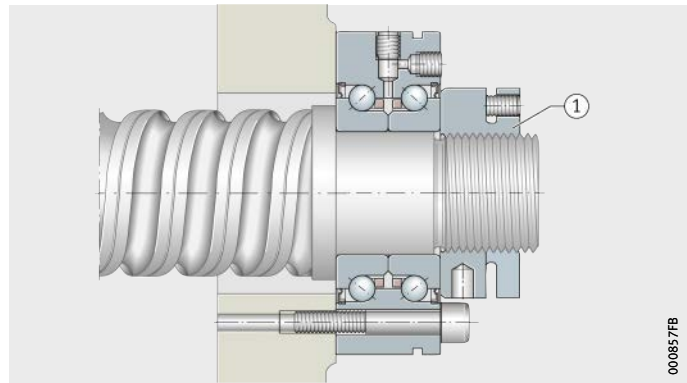

000857FB

ZKLF..-2RS
ZKLF..-ZZ
ZKLF..-2RS-PE

① Extraction slot

Figure 4

Outer ring screw mounted in bore, preloaded by locknut AM

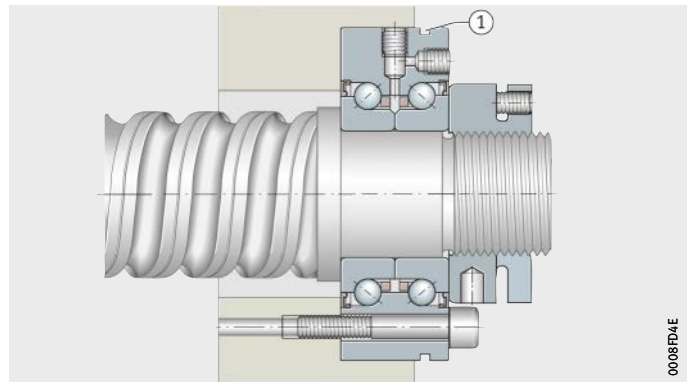

0008FD4E

With less stringent tolerances

Axial angular contact ball bearings ZKLF..-2RS-PE correspond to series ZKLF but have an axial runout tolerance within tolerance class 5 to ISO 492 (DIN 620-2), less stringent diameter tolerances and the suffix PE. They are used where a lower positional accuracy is acceptable. As a result, the requirement for accuracy of the adjacent construction is lower with these bearings.

Heavy series

Axial angular contact ball bearings ZKLF..-2RS and ZKLF..-ZZ are also available in a heavy series. For the same shaft diameter, they have a larger cross-section and thus higher basic load ratings.

Axial angular contact ball bearings

Advantages of axial angular contact ball bearings ZKLf compared with solutions based on single bearings

The aim of the designer must be to achieve a combination of a drive spindle function with the longest possible operating life and the lowest possible overall costs.

The operating life is dependent on the correct preloading of the bearings and effective sealing. A reduction in the mechanical interfaces (the number of components) also means a reduction in possible mounting errors.

This is made possible by the use of axial angular contact ball bearings ZKLf. The bearings are supplied already correctly matched and sealed. This eliminates the need for mounting of individual bearings with its associated errors. Through flange mounting on a flat surface, alignment of the threaded spindle is a very simple process.

In the analysis of overall costs, it must also be taken into consideration that the use of single bearings involves not only the bearing costs themselves but also the following outlays, *Figure 5*:

- manufacturing costs for additional components (housing, cover)
- costs for seals
- mounting costs for the bearing unit
- costs for matching work in alignment of the spindle
- corresponding stockholding costs and logistics outlay.

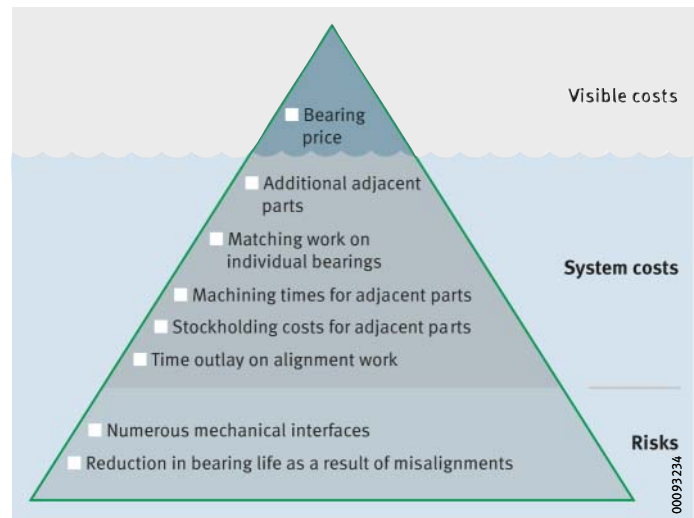

Figure 5
Outlay in single bearing solutions,
presented as an iceberg diagram

Matched pair design

Bearings of series ZKLF..-2RS-2AP comprise a matched pair of bearings ZKLF..-2RS, *Figure 6* and *Figure 7*. The individual bearings are matched to each other.

Matched bearings have an arrow marking on the outside surface of the outer rings. When the bearings are arranged correctly, the lip seals face outwards. During fitting, the hole pattern of the two bearings must match, not the marking.

ZKLF..-2RS-2AP

Figure 6
Matched pair,
outer ring screw mounted in bore,
preloaded by locknut AM

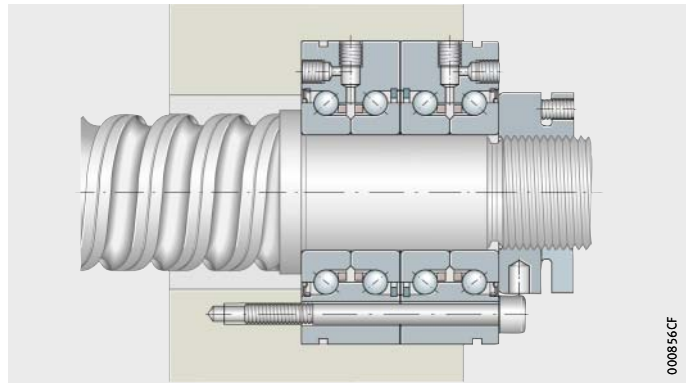

ZKLF..-2RS-2AP

① Support ring
(not included in scope of delivery)

Figure 7
Matched pair, screw mounted
on face of adjacent construction,
preloaded by locknut AM

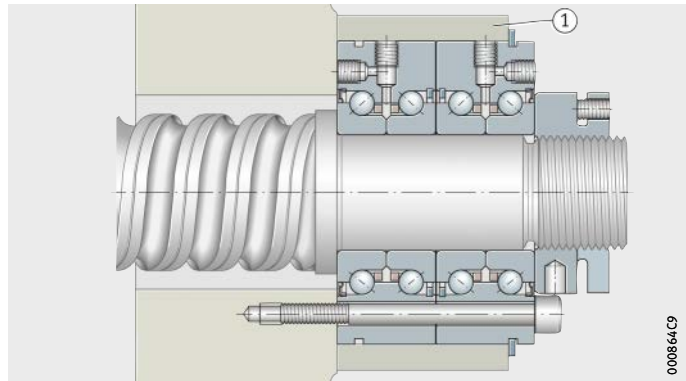

Seals

Bearings with the suffix 2RS have lip seals and highly effective sealing.

Bearings with the suffix 2Z are sealed using minimal gap seals and are suitable for higher speeds.

Lubrication

The bearings are greased using a lithium soap grease to GA28 and can be lubricated via the lubrication connectors in the outer ring. For the majority of applications, the initial greasing is sufficient for the whole bearing operating life.

Axial angular contact ball bearings

Double row design, without fixing holes

Axial angular contact ball bearings ZKLN are mounted in a housing bore, *Figure 8* and *Figure 9*. The bearing outer ring is axially located by a ring nut or flange cover.

ZKLN..-2RS
ZKLN..-2Z

Figure 8

Outer ring located by ring nut, preloaded by locknut AM

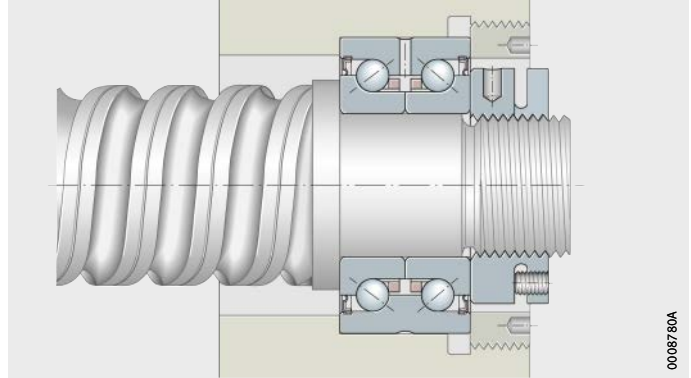

0008780A

ZKLN..-2RS
ZKLN..-2Z

Figure 9

Outer ring located by flange cover, preloaded by locknut AM

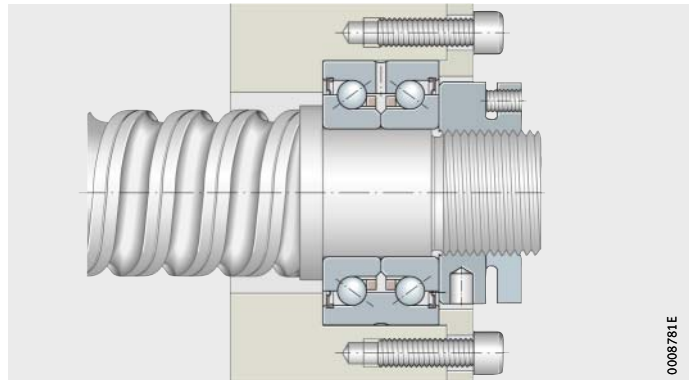

0008781E

With less stringent tolerances

Axial angular contact ball bearings ZKLN..-2RS-PE correspond to series ZKLN but have an axial runout tolerance within tolerance class 5 to ISO 492 (DIN 620-2), less stringent diameter tolerances and the suffix PE. They are used where a lower positional accuracy is acceptable. As a result, the requirement for accuracy of the adjacent construction is lower with these bearings.

Heavy series

Axial angular contact ball bearings ZKLN..-2RS and ZKLN..-2Z are also available in a heavy series. For the same shaft diameter, they have a larger cross-section and thus higher basic load ratings.

Matched pair design

Bearings of series ZKLN...-2RS-2AP comprise a matched pair of bearings ZKLN...-2RS, *Figure 10*. The individual bearings are matched to each other.

Matched bearings have an arrow marking on the outside surface of the outer rings. When the bearings are arranged correctly, the lip seals face outwards.

The bearing outer ring is axially located by a ring nut or flange cover, *Figure 10*.

ZKLN...-2RS-2AP

Figure 10
Matched pair,
outer ring located by ring nut,
preloaded by locknut AM

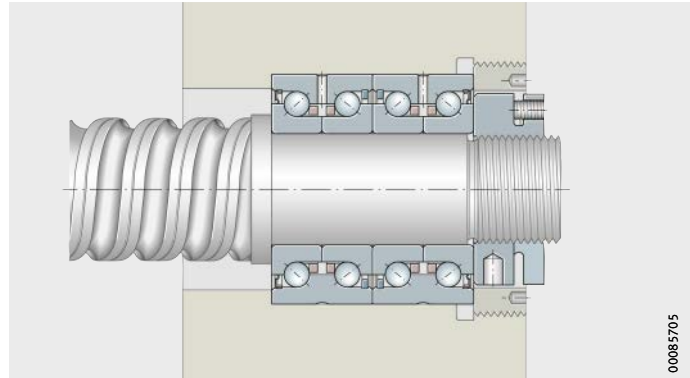

Seals

Bearings with the suffix 2RS have lip seals and highly effective sealing.

Bearings with the suffix 2Z are sealed using minimal gap seals and are suitable for higher speeds.

Lubrication

The bearings are greased using a lithium soap grease to GA28 and can be lubricated via a lubrication slot and lubrication holes in the outer ring. For the majority of applications, the initial greasing is sufficient for the whole bearing operating life.

The axial angular contact ball bearing ZKLN0619-2Z cannot be relubricated.

Axial angular contact ball bearings

Hybrid design HC



With the hybrid axial angular contact ball bearings ZKLF..-HC and ZKLN..-HC, Schaeffler offers reliable solutions to the problem of “false brinelling”, known in relation to and occasionally occurring in feed axes with ball screw drives, in which balls are thought to cause indentations in the raceways. Premature bearing failures due to this type of damage, often described as fluting, can thus be avoided.

If operating conditions are present, however, where there is insufficient relative motion between the rolling contact partners, the lubricant film at the rolling contact is interrupted and partial dry running occurs (direct steel/steel contact). Such operating conditions occur, for example, with small swivel angles, highly dynamic positional regulation or vibrations in a stationary state. This can occasionally lead, within a few hours, to premature bearing failure through false brinelling.

Ceramic rolling elements offer the possibility of permanently eliminating this harmful steel/steel contact, *Figure 11*.



Figure 11
Hybrid axial angular contact
ball bearing ZKLF..-HC

Advantages of hybrid bearings	<p>The advantages of hybrid bearings in comparison with steel bearings are:</p> <ul style="list-style-type: none"> ■ reliability, even in short stroke operation for long periods ■ a three-fold increase in grease operating life ■ higher speed capability. <p>Other characteristics are as follows:</p> <ul style="list-style-type: none"> ■ They give the same basic rating life ■ The fact that the basic static load ratings are approx. 30% lower is irrelevant in many screw drive applications ■ The axial rigidity in the raceway system is only 5% lower. 	
Availability	<p>The following series and sizes are available as standard in the hybrid design:</p> <ul style="list-style-type: none"> ■ ZKLF..-2RS, ZKLF..-2Z, ZKLN..-2RS, ZKLN..-2Z ■ bearings with d = 20 mm to 100 mm ■ all other series and sizes can be offered by agreement with Triondur coating in order to prevent false brinelling. 	
Ordering example	<p>Double row axial angular contact ball bearing ZKLF with rings made from rolling bearing steel and balls made from ceramic (Hybrid Ceramic), minimal gap seals</p>	
Ordering designation	ZKLF40100-2Z-HC	
Further information	<ul style="list-style-type: none"> ■ Detailed information on “false brinelling” in feed axes and hybrid designs: see reprint SSD 26, Hybrid Axial Angular Contact Ball Bearings for Screw Drives ■ Download and ordering: http://medien.schaeffler.de. 	

Axial angular contact ball bearings

**Single row design,
suitable for any combination**

The axial angular contact ball bearings 7602, 7603 and BSB are designed as universal bearings, *Figure 12* and *Figure 13*.

They can be used in sets in any combination for different requirements, *Figure 13*.

**7602, 7603
BSB**

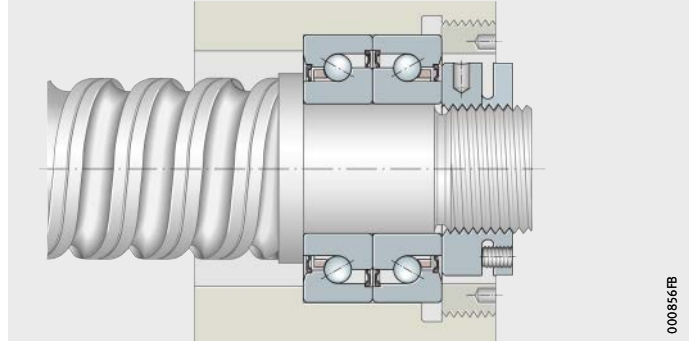
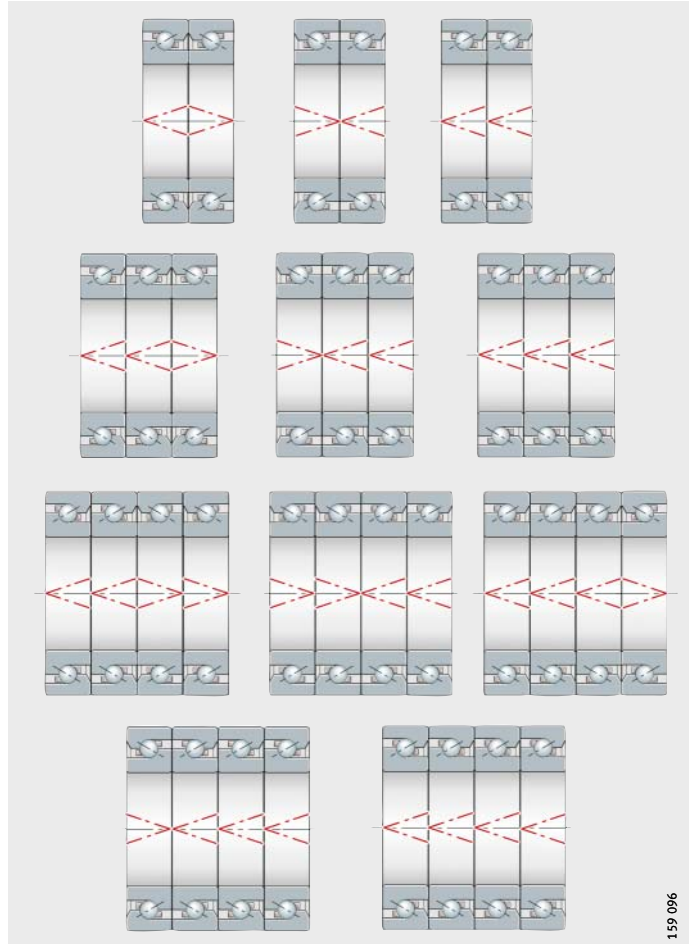

Figure 12
Single row axial angular
contact ball bearings,
2 bearing set in X arrangement

000856FB



**7602, 7603
BSB**

Figure 13
Bearing set combinations

159 096

Marking of the mounting position

The bearings have arrow marks on the outside diameter to indicate the contact angle arrangement:

- <> is an O arrangement
- >< is an X arrangement
- << is a tandem arrangement.

In bearings with seals (BSB...-2Z-SU), the contact angle can also be recognised from the seal colour after mounting:

- A brown seal on the outside indicates an O arrangement (side with high inner ring shoulder)
- A red seal on the outside indicates an X arrangement (side with low inner ring shoulder).



Precision matched to requirements

The dimension tables contain the two axial angular contact ball bearings BSB...-T and BSB...-SU with identical dimensions. Both series differ slightly in their rolling element system. The essential difference lies in the precision of the raceways.

Axial angular contact ball bearings BSB...-T and 760 are manufactured to high requirements comparable with those of main spindle bearings. As a result, running noise is extremely low even at high speeds. These bearings are therefore used in high precision screw drive applications and in devices used in low-noise environments such as laboratories.

For applications in general machine building, for example in machine tools and handling systems, axial angular contact ball bearings BSB...-SU have adequate precision.



Seals

Single row axial angular contact ball bearings of the basic design are not sealed.

The most common bearing sizes are also available in sealed versions:

- 760...-2RS and BSB...-2RS
contact lip seals 2RS with minimal contact force
- BSB...-2Z-SU
minimal gap seals 2Z.

Lubrication

Single row axial angular contact ball bearings of the open basic design are not greased. These bearings are used in preference for applications with oil lubrication.

Alternatively, the bearings can be ordered with the suffix L055. These are greased with the high performance grease Arcanol MULTITOP and can be relubricated via the open raceway gap in the end face.

Single row, sealed axial angular contact ball bearings are greased for life with this grease.

Axial angular contact ball bearings

Angular contact ball bearing unit, with fixing holes

Angular contact ball bearing units ZKLR are low-cost bearings and particularly economical. They comprise a deep drawn sheet steel housing with an integral matched pair of angular contact ball bearings in an X arrangement, *Figure 14*. The housing has a Corrotect coating and is thus protected against corrosion. The ball bearings are sealed on both sides by lip seals or gap seals. The bearing assembly is preloaded clearance-free.

ZKLR..-2Z
ZKLR..-2RS

Figure 14
Angular contact ball bearing unit

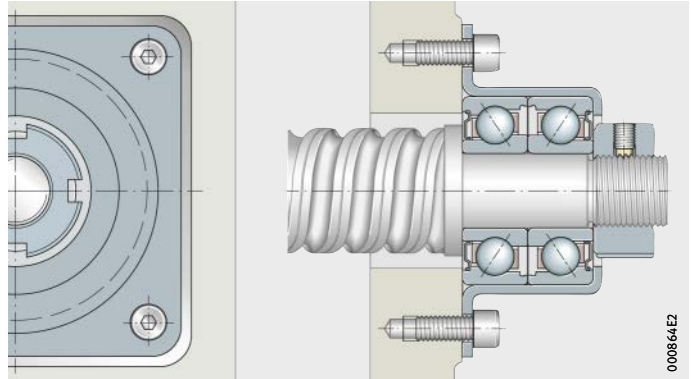

Particularly easy to fit

The units are particularly easy to fit:

- They are directly flange mounted on the, for example, milled face of the adjacent construction. This eliminates the need for precise, costly fits and additional flange covers for seating and axial location of the bearings.
- No additional components are required for location of the bearings in the housing.
- The possible errors in mounting are reduced due to the smaller number of components compared to conventional solutions.
- They align themselves by means of the screw drive nut during mounting. This effectively eliminates any distortion due to misalignment of the bearing seats.
- They have a defined preload. There is thus no need for preloading of the bearings during mounting.
- Axially clearance-free location on the spindle is sufficient.

Seals	Bearings with the suffix 2RS have lip seals and highly effective sealing. Bearings with the suffix 2Z are sealed using gap seals and are suitable for higher speeds.
Lubrication	The bearings are greased for life using a lithium soap grease to DIN 51825–K2N–30.
Operating limits	<p>The units are highly suitable, due to their dimensions and design, for space-saving and simple bearing arrangements in highly dynamic feed screw drives.</p> <p>Areas of application include:</p> <ul style="list-style-type: none"> ■ inspection and measuring machines ■ small machining equipment ■ medical and laboratory equipment ■ machines in precision engineering and electronic component manufacture ■ simplification of the bearing arrangement through the use of complete units.



Axial angular contact ball bearings

Double row design, with flange, with fixing holes

Series ZKLFA has a stepped outer ring. It can therefore be screw mounted easily on the adjacent construction, *Figure 15*. The flange has flattened areas on both sides, so the radial design envelope in the adjacent construction can be kept very small.

ZKLFA..-2RS
ZKLFA..-2Z

Figure 15
Outer ring screw mounted on adjacent construction, preloaded by locknut ZM

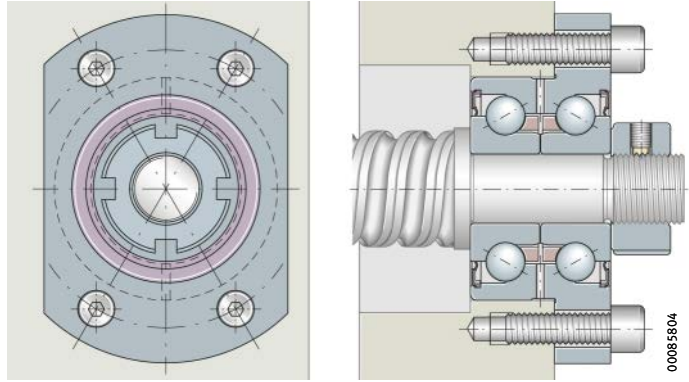

Seals

Bearings with the suffix 2RS have lip seals and highly effective sealing. Bearings with the suffix 2Z are sealed using gap seals and are suitable for higher speeds.

Lubrication

The bearings are greased using a lithium soap grease to GA28 and can be lubricated via a lubrication slot and lubrication holes in the outer ring. For the majority of applications, the initial greasing is sufficient for the whole bearing operating life.

The axial angular contact ball bearing ZKLFA0630-2Z cannot be relubricated.

Triple row design, with flange, with fixing holes

Axial angular contact ball bearings DKLFA..-2RS have, in addition to two rows of balls with a contact angle of 60° in an O arrangement, a further row of balls, *Figure 16* and *Figure 17*. Due to this additional row, the bearings can support higher axial loads in one direction.

Due to the stepped outer ring, the bearings can be easily flange mounted on the adjacent construction. The flange has flattened areas on both sides. As a result, it requires only a small radial design envelope in the adjacent construction.



In order to make full use of the load carrying capacity of bearings DKLFA..-2RS, their design requires that they are subjected to continuous load in the main load direction. They are therefore used mainly in screw drives with a locating/locating bearing arrangement and tensioned spindles or in vertically arranged screw drive bearing arrangements.

For axial angular contact ball bearing units DKLFA, the locknut tightening torque must be configured in accordance with the load data.

For design of the bearing arrangement, please contact us.

DKLFA...-2RS

Figure 16
Outer ring screw
mounted on adjacent construction
without radial centring,
preloaded by locknut AM

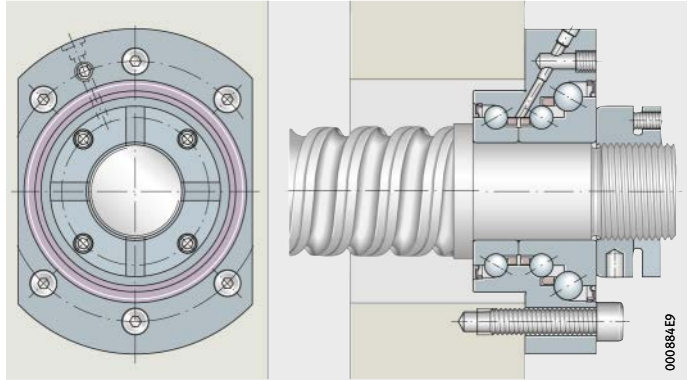

DKLFA...-2RS

Figure 17
Outer ring screw
mounted on adjacent construction,
preloaded by locknut AM

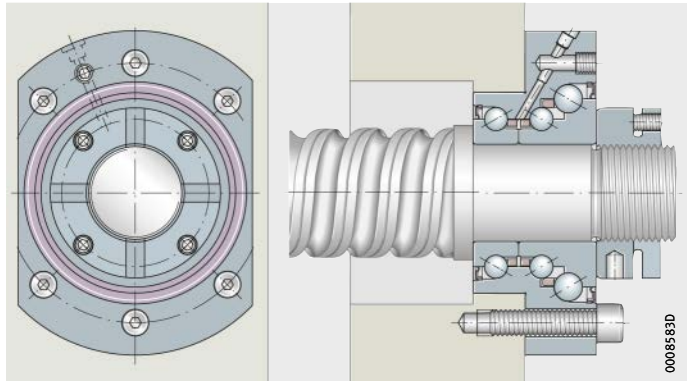

Seals

Triple row axial angular contact ball bearings have lip seals on both sides.

Lubrication

The bearings are greased using a lithium soap grease to GA28. If necessary, lubrication can be carried out via a threaded connector for central lubrication systems on the flange side.

Axial angular contact ball bearings

Operating temperature

Axial angular contact ball bearings are suitable for operating temperatures from $-30\text{ }^{\circ}\text{C}$ to $+120\text{ }^{\circ}\text{C}$, restricted by the grease, the seal material and the plastic cages in the ball and cage assemblies.



The operating temperature influences the dynamic bearing characteristics. The values given in the dimension table are based on a room temperature of $+20\text{ }^{\circ}\text{C}$.

Cages

The axial angular contact ball bearings have plastic cages. The cage design is not indicated in the suffix.

In axial angular contact ball bearings 7602, 7603 and BSB, the polyamide cages are indicated by the suffix TVP or T.

Suffixes

Suffixes for available designs: see table.

Available designs

Suffix	Description	Design
PE	Less stringent bearing design	Standard
T, TVP	Polyamide cage	
2AP	Axial angular contact ball bearings, matched pair (ZKLN, ZKLF)	
2RS	Contact lip seals on both sides	
2Z	Minimal gap seals on both sides	
L055	Greased with high performance grease Arcanol MULTITOP	
SU	Universal bearing; single bearings can be used in sets in any combination required	
HC	Hybrid Ceramic, rings made from rolling bearing steel, balls made from ceramic	Special design, available by agreement

Structure and meaning of designations

The structure of the designations of axial angular contact ball bearings is specific to the series. The designation of the series is followed by indications of the bearing size and finally indications of the design variants and seals, see tables, *Figure 18* and *Figure 19*, page 28.

Structure of designations of axial angular contact ball bearings

Feature	Indication, example	Series ①				
		ZKLF	ZKLN	ZKLFA	DKLFA	ZKLR
② Inside diameter	15	●	●	●	●	●
③ Outside diameter	30	●	●	–	–	–
Flange outside diameter	63	–	–	●	●	–
Flange height	24	–	–	–	–	●
④ Minimal gap seals	2Z	●	●	●	–	●
Lip seals	2RS	●	●	●	●	●
⑤ Standard design	–	●	●	●	●	●
Less stringent accuracy	PE	●	●	–	–	–
Two bearings in matched pair	2AP	●	●	–	–	–
With ceramic balls	HC	●	●	–	–	–



Structure of designations of axial angular contact ball bearings (continued)

Feature	Indication, example	Series ①		
		76	BSB..-T	BSB..-SU
① ISO diameter series 2	02	●	–	–
ISO diameter series 3	03	–	–	–
② Inside diameter	25	●	●	●
③ Outside diameter	62	–	●	●
④ Without seals	–	●	●	●
Lip seals and greased with Arcanol MULTITOP	2RS	●	●	–
Minimal gap seals and greased with Arcanol MULTITOP	2Z	–	–	●
⑤ Polyamide cage	T, TVP	●	●	–
⑥ Universal single bearings suitable for use in sets in any combination required				
Single bearing	–	●	●	–
	SU	–	–	●
2 bearing set	D	●	●	●
3 bearing set	T	●	●	●
4 bearing set	Q	●	●	●
⑦ Ungreased (bearing without seals)	–	●	●	●
Bearing greased with Arcanol MULTITOP	L055	●	●	●

● Indicated in ordering designation.

Axial angular contact ball bearings

ZKLFA1563-2RS = example,
see table, page 27

Figure 18
Structure of ordering designations
of axial angular contact ball
bearings ZKLF, ZKLN, ZKLFA,
DKLFA and ZKLR

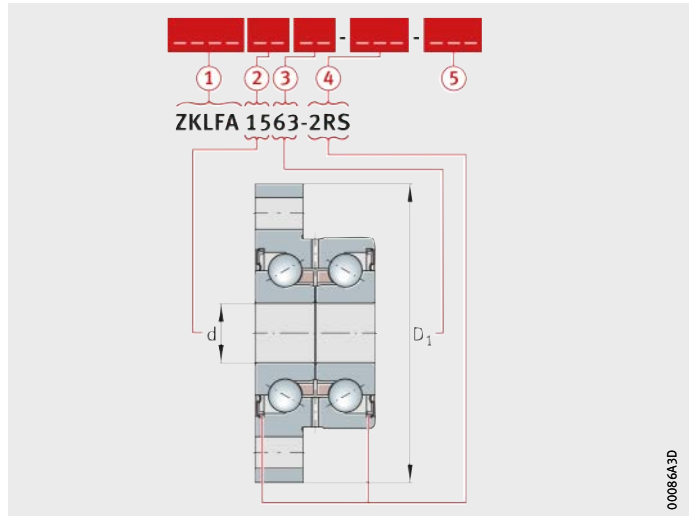

BSB025062-T = example,
see table, page 27

Figure 19
Structure of ordering designations
of axial angular contact ball
bearings 76, BSB...-T, BSB...-SU

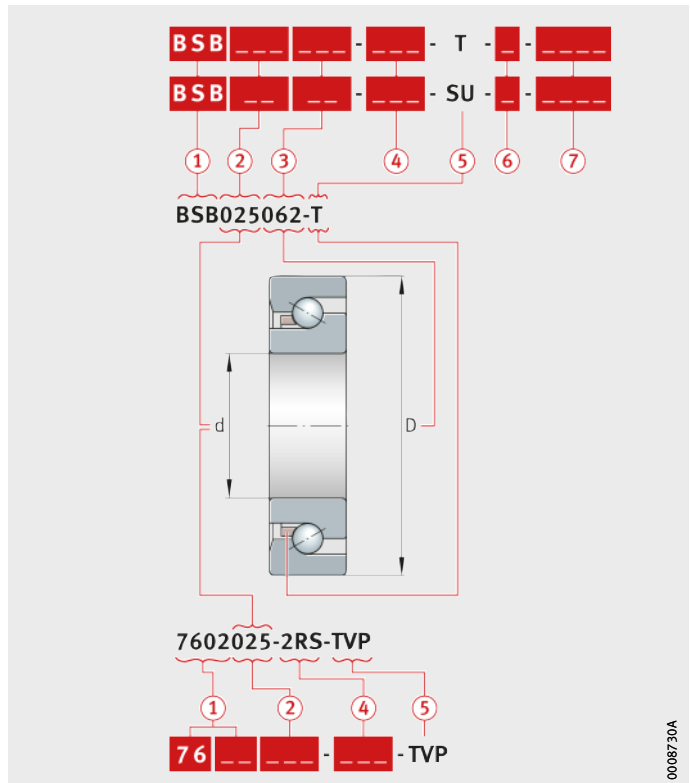

Design and safety guidelines

Basic rating life

The decisive factors in determining the bearing size are the basic rating life, the static load safety factor and the axial limiting load.

The rating life L_{10} or L_{10h} is calculated as follows:

$$L_{10} = \left(\frac{C}{P}\right)^p$$

$$L_{10h} = \frac{16\,666}{n} \cdot \left(\frac{C}{P}\right)^p$$

L_{10} Basic rating life in millions of revolutions

L_{10h} Basic rating life in operating hours

C_r, C_a Basic dynamic radial or axial load rating, see dimension table

C_r is valid for a contact angle $\alpha \leq 45^\circ$,
 C_a is valid for a contact angle $\alpha > 45^\circ$

P Equivalent dynamic bearing load

p Life exponent $p = 3$

n Operating speed. min^{-1}



Static load safety factor

The static load safety factor S_0 indicates the security against impermissible permanent deformations in the bearing:

$$S_0 = \frac{C_0}{P_0}$$

S_0 Static load safety factor

C_{0r}, C_{0a} Basic static radial or axial load rating, see dimension table

C_{0r} is valid for a contact angle $\alpha \leq 45^\circ$,
 C_{0a} is valid for a contact angle $\alpha > 45^\circ$

P_0 Maximum static load of bearing.



In machine tools, S_0 should be ≥ 4 .

A value below this limit is only possible after analysis of the individual case. This will include a calculation study of the contact ellipse value k_s . The value describes the position of the contact ellipse in the bearing with complete ($k_s = 1$) or partial support ($k_s < 1$).

We recommend that the calculation should be requested from Schaeffler, stating the load and speed duty cycle.

Axial angular contact ball bearings

Resultant and equivalent bearing load

The resultant axial bearing load $F_{a\ res}$ is determined from the axial operating load F_{aB} and taking account of the axial preload.

Axial and radial operating loads

Under pure axial load, $P = F_{a\ res}$. If additional radial operating loads are present, P must be calculated as follows:

$$P = X \cdot F_r + Y \cdot F_{a\ res}$$

P N
Equivalent dynamic bearing load
 F_r N
Radial dynamic bearing load
 $F_{a\ res}$ N
Resultant axial dynamic bearing load
 X, Y –
Radial load factor, axial load factor.
The load factors X and Y can be taken from the following table.

Load factors X and Y

Load ratio	Load factors	
	X	Y
$\frac{F_{a\ res}}{F_r} \leq 2,17$	1,9	0,55
$\frac{F_{a\ res}}{F_r} > 2,17$	0,92	1

Load varying in steps

In this case, P and n are calculated as follows:

$$P = p \sqrt{\frac{q_1 \cdot n_1 \cdot P_1^p + \dots + q_z \cdot n_z \cdot P_z^p}{q_1 \cdot n_1 + \dots + q_z \cdot n_z}}$$

$$n = \frac{q_1 \cdot n_1 + \dots + q_z \cdot n_z}{100}$$

P N
Equivalent dynamic bearing load
 p –
Life exponent $p = 3$
 q %
Time proportion
 n min⁻¹
Operating speed.

Static limiting load diagrams for ZKLR

The easy-to-use static limiting load diagrams allow quick verification of the bearing size of angular contact ball bearing units ZKLR, as a function of the axial and radial operating load, *Figure 21*, page 32 and *Figure 22*, page 32. The decisive requirement is that the intersection between the axial and radial load must be below the limit line.

Example, *Figure 20*: If the operating loads F_a and F_r are below the limit line, the bearing size is suitable for the application.

For some angular contact ball bearing units ZKLR, equations are available instead of the diagrams, see table.



Resultant and equivalent bearing load P for ZKLR

Designation	Equivalent bearing load P
ZKLR0624-2Z	$P = 140 + 0,11 \cdot F_a^{1,45} + 0,012 \cdot F_r^{1,66}$
ZKLR0828-2Z	$P = 215 + 0,21 \cdot F_a^{1,32} + 0,0053 \cdot F_r^{1,74}$
ZKLR1035-2Z	$P = 240 + 0,49 \cdot F_a^{1,18} + 0,016 \cdot F_r^{1,55}$
ZKLR1244-2RS	$P = 720 + 0,34 \cdot F_a^{1,32} + 0,095 \cdot F_r^{1,54}$
ZKLR1547-2RS	$P = 550 + 0,0074 \cdot F_a^{1,55} + 0,045 \cdot F_r^{1,35}$
ZKLR2060-2RS	$P = 930 + 0,0059 \cdot F_a^{1,54} + 0,038 \cdot F_r^{1,35}$

$F_r = 600 \text{ N}$
 $F_a = 300 \text{ N}$

The bearing is suitable in static terms since the intersection F_a/F_r is below the limit line.

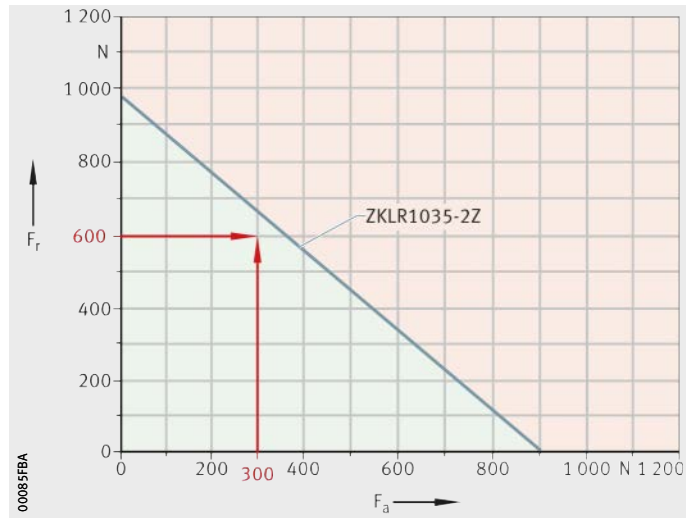
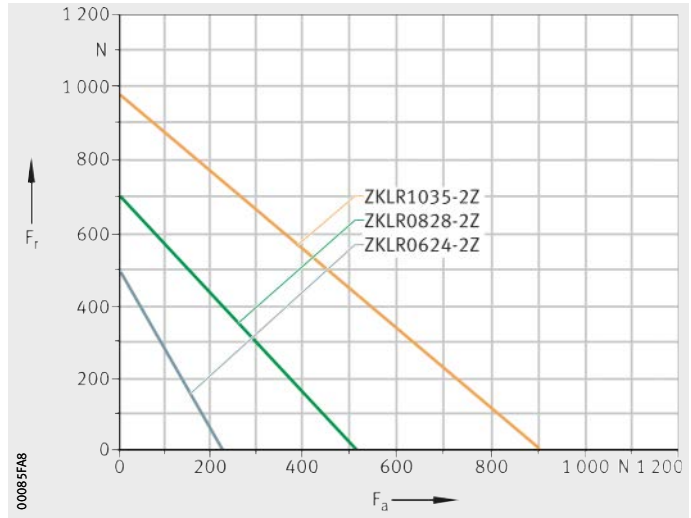

Figure 20
 Static limiting load diagram, example ZKLR1035-2Z

Axial angular contact ball bearings

F_r = radial load
 F_a = axial load

Figure 21
 Static limiting load diagram
 for ZKLR...-2Z



F_r = radial load
 F_a = axial load

Figure 22
 Static limiting load diagram
 for ZKLR...-2RS

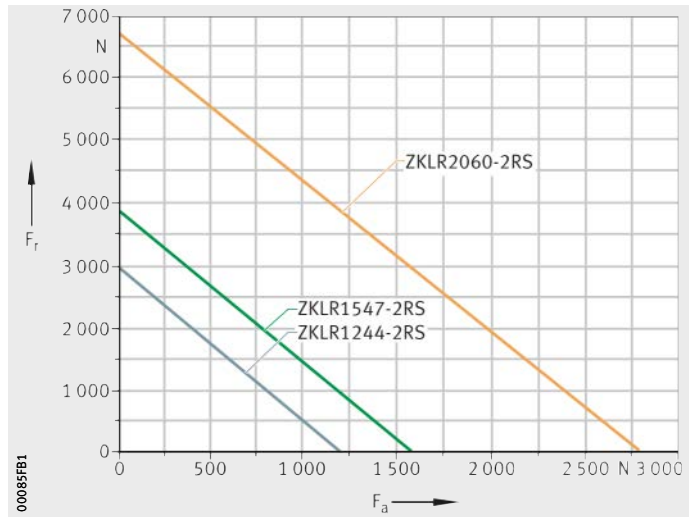

Resultant and equivalent bearing load P for ZKLN, ZKLF, ZKLFA, DKLFA, BSB, 7602, 7603

The bearings are axially preloaded to a defined value if the recommended precision locknuts are used and the correct nut tightening torque is applied. The resultant axial bearing load $F_{a\ res}$ is determined from the axial operating load F_{aB} and taking account of the axial preload, *Figure 23* to *Figure 34*, page 37. For 7602, 7603 and BSB, the diagrams for $F_{a\ res}$ are based on two-bearing sets in an O or X arrangement, see page 20. For other set combinations, please contact us.



A load in excess of the limiting load will cause the rolling element row without load to lift off the raceway, in which case the bearing is no longer under preload. As a result, slippage will occur during highly dynamic acceleration events, which will lead to wear. Based on experience, the effect is less pronounced in the case of ball bearings and is therefore non-critical.

For extreme moment loads and statically overdefined systems (locating/locating bearing arrangements), please contact us. The calculation program BEARINX can give a precise design in this case, see page 154.



F_{aB} = operating load
 $F_{a\ res}$ = resultant bearing load
 \circ = limiting load

Figure 23
 Resultant bearing load for ZKLN and ZKLFA, up to $d = 10\text{ mm}$

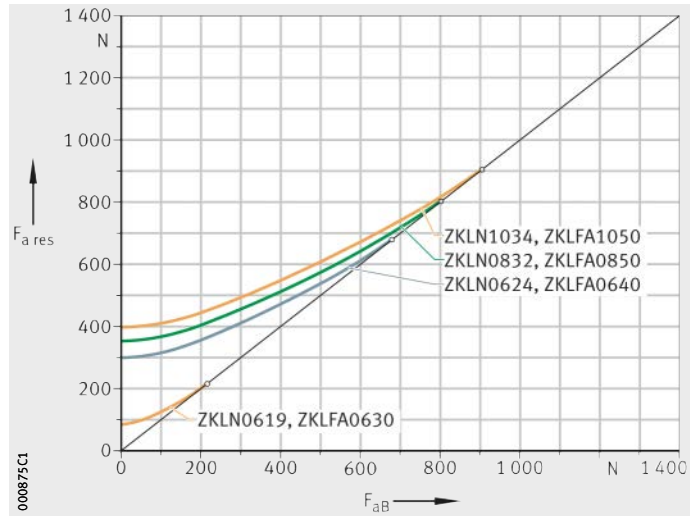

Axial angular contact ball bearings

Example (red line):
 Axial angular contact ball bearing ZKLN1545
 $F_{aB} = 1500 \text{ N}$
 $F_{a \text{ res}} \approx 1750 \text{ N}$
 Loading by operating load and preload

F_{aB} = operating load
 $F_{a \text{ res}}$ = resultant bearing load
 \circ = limiting load

Figure 24
 Resultant bearing load for ZKLN, ZKLF and ZKLFA, up to $d = 17 \text{ mm}$

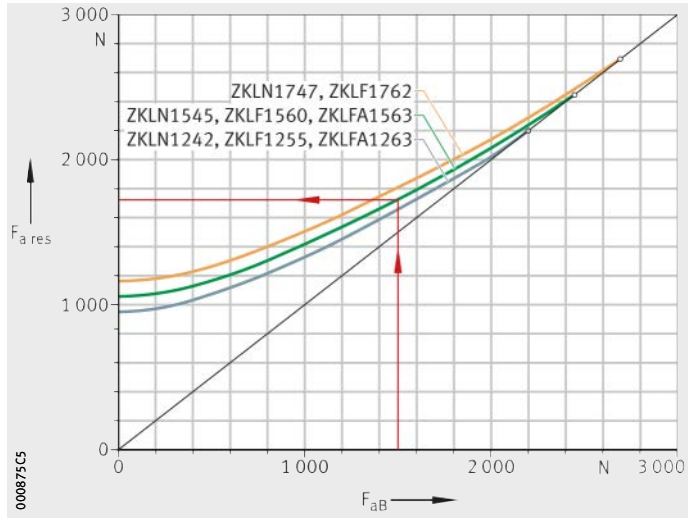

F_{aB} = operating load
 $F_{a \text{ res}}$ = resultant bearing load
 \circ = limiting load

Figure 25
 Resultant bearing load for ZKLN, ZKLF, from $d = 20 \text{ mm}$ to 50 mm

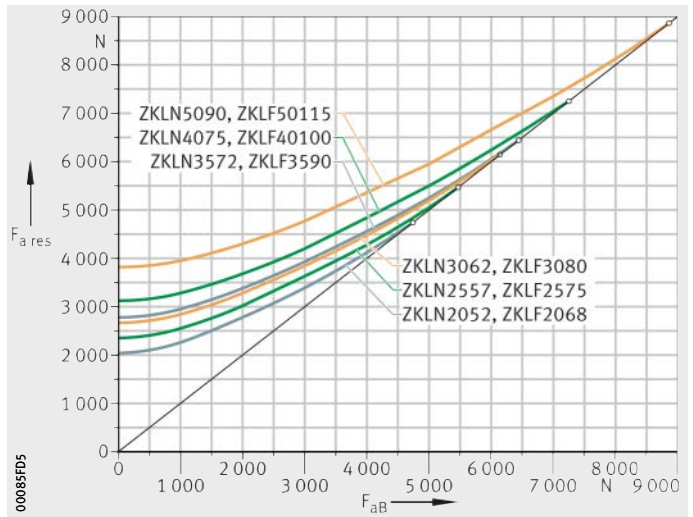

F_{aB} = operating load
 $F_{a \text{ res}}$ = resultant bearing load
 \circ = limiting load

Figure 26
 Resultant bearing load for ZKLN, ZKLF, heavy series

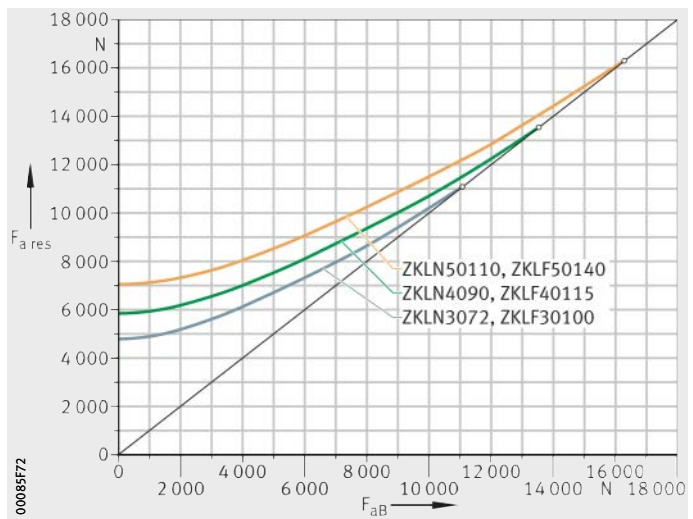

F_{aB} = operating load
 $F_{a\text{res}}$ = resultant bearing load
 \circ = limiting load

Figure 27
 Resultant bearing load
 for ZKLN, ZKLF,
 from $d = 60$ mm

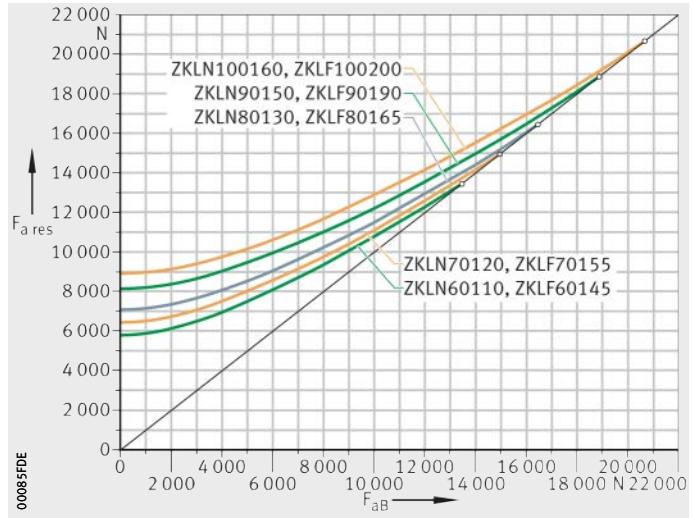

F_{aB} = operating load
 $F_{a\text{res}}$ = resultant bearing load
 \circ = limiting load

Figure 28
 Resultant bearing load
 for ZKLF,
 $d = 100$ mm

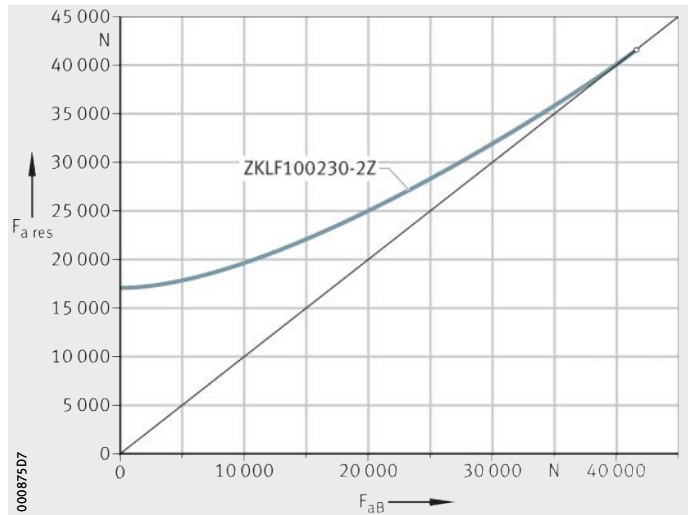

F_{aB} = operating load
 $F_{a\text{res}}$ = resultant bearing load
 \circ = limiting load

Figure 29
 Resultant bearing load
 for ZKLN...-2AP and ZKLF...-2AP

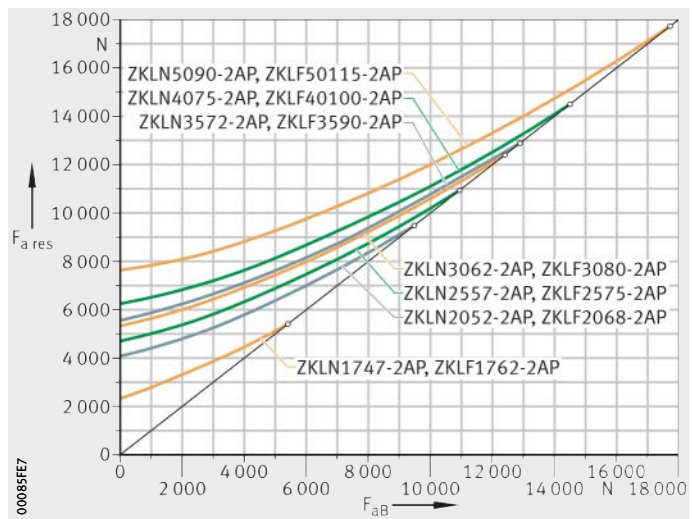

Axial angular contact ball bearings

F_{aB} = operating load
 $F_{a\ res}$ = resultant bearing load
 \circ = limiting load

Figure 30
 Resultant bearing load for BSB...-T

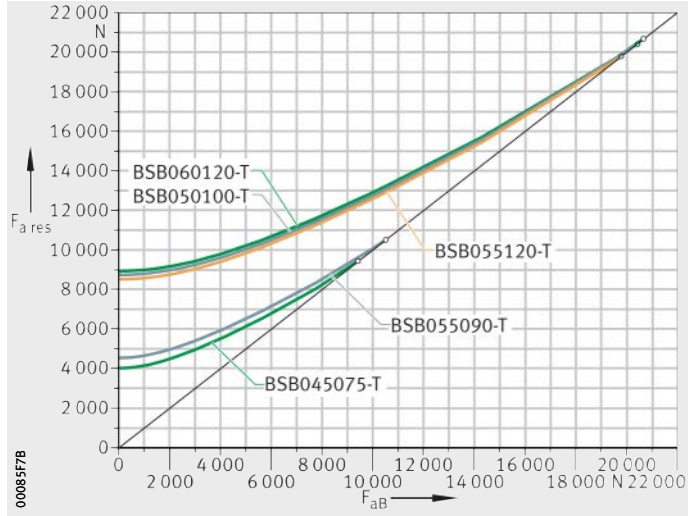

F_{aB} = operating load
 $F_{a\ res}$ = resultant bearing load
 \circ = limiting load

Figure 31
 Resultant bearing load for BSB...-SU

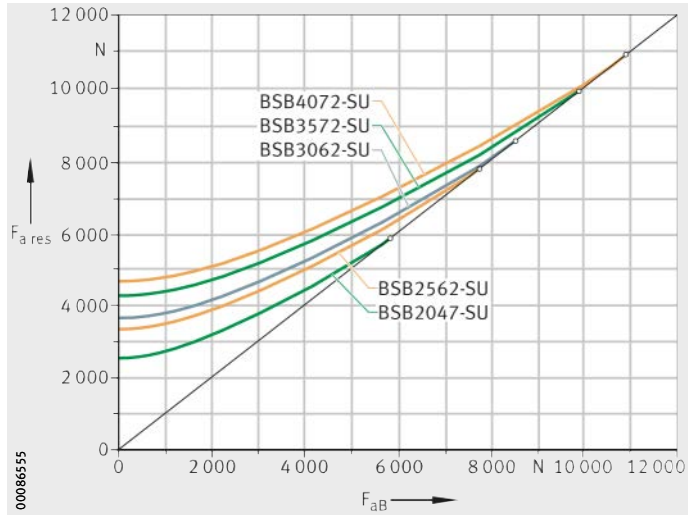

F_{aB} = operating load
 $F_{a\ res}$ = resultant bearing load
 \circ = limiting load

Figure 32
 Resultant bearing load for 7602012 to 7602045

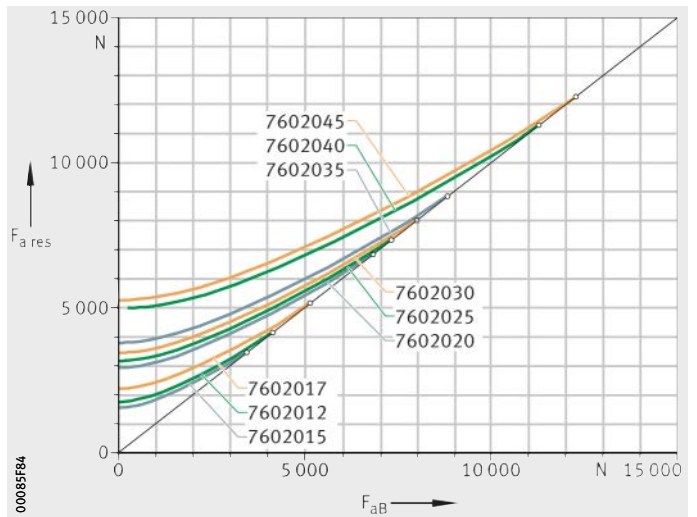

F_{aB} = operating load
 $F_{a\text{ res}}$ = resultant bearing load
 ° = limiting load

Figure 33
 Resultant bearing load
 for 7602050 to 7602060

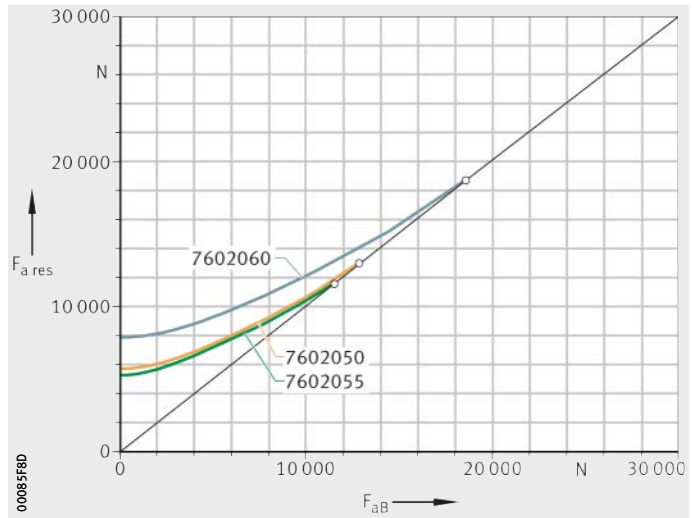

F_{aB} = operating load
 $F_{a\text{ res}}$ = resultant bearing load
 ° = limiting load

Figure 34
 Resultant bearing load
 for 7603020 to 7603065

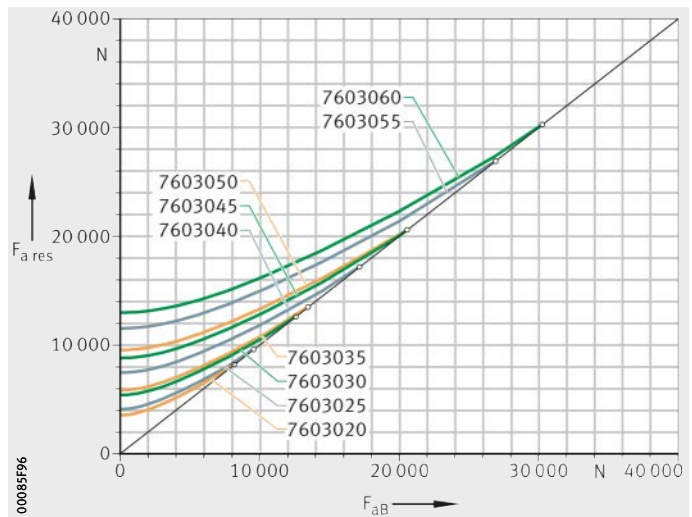

Axial angular contact ball bearings

Maximum radial load on screw connections for ZKLF

If bearings of series ZKLF are screw mounted on a flat adjacent construction, the maximum radial load that can be supported by the screw connections must be taken into consideration.

If the screws used are to DIN EN ISO 4762 as stated in the dimension tables, the maximum radial load that can be supported before the outer ring moves, in the case of dry components, is restricted to $\approx 0,1 \times C_{0a}$. If the outer ring is additionally bonded in place using, for example, Loctite 638, the maximum radial load that can be supported increases to approx. $\approx 0,5 \times C_{0a}$.

Influence of the rolling element set on permissible radial loads

If the maximum radial loads that can be supported (without any axial load content) are considered in relation to the rolling element set, it can be seen that:

- With a static load safety factor of $S_0 \geq 4$ as required for machine tools, the load that can be supported by the screw connections of the outer ring is in any case greater than the radial load restricted by the rolling element set.
- This means that (at least in theory) radial loads can be supported that, in relation to the rolling element set, will lead to a static load safety factor of $S_0 \leq 1$ (incipient plastic deformation of rolling elements), if the outer ring is additionally bonded in place.
- This means that, under normal design criteria and with the decisive static load safety factor for the corresponding areas of application (e.g. $S_0 = 4$ for machine tools), the rolling element set is always the decisive criterion.

Permissible static axial load for ZKLF

For axial angular contact ball bearings ZKLF, the permissible static axial load in the direction of the screw connections, *Figure 35*, is defined as follows:

$$P_{0\text{ per}} \leq \frac{C_{0a}}{2}$$

$P_{0\text{ per}}$ N
Permissible static axial load

C_{0a} N
Basic static axial load rating C_{0a} , see dimension tables.

ZKLF

Figure 35
Static axial load in the direction of the screw connections

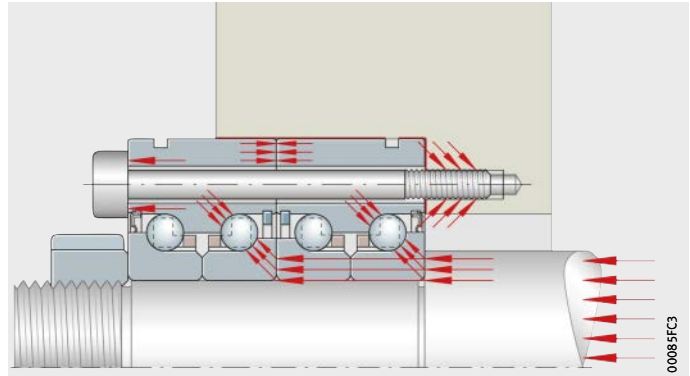

Design of screw drive bearing arrangements

For screw drive bearing arrangements, a distinction is made between two design principles, a screw drive with a rotating spindle and a screw drive with a rotating nut. The type of bearing arrangement has an influence on the critical whirling speed, *Figure 36*.

Calculation example:
diameter of threaded spindle = 40 mm
spindle length = 2 000 mm

X = X arrangement
O = O arrangement

- ① Critical whirling speed, calculated
- ② Locating/non-locating bearing arrangement
- ③ Locating/locating bearing arrangement

Figure 36
Effect of bearing arrangement on critical whirling speed

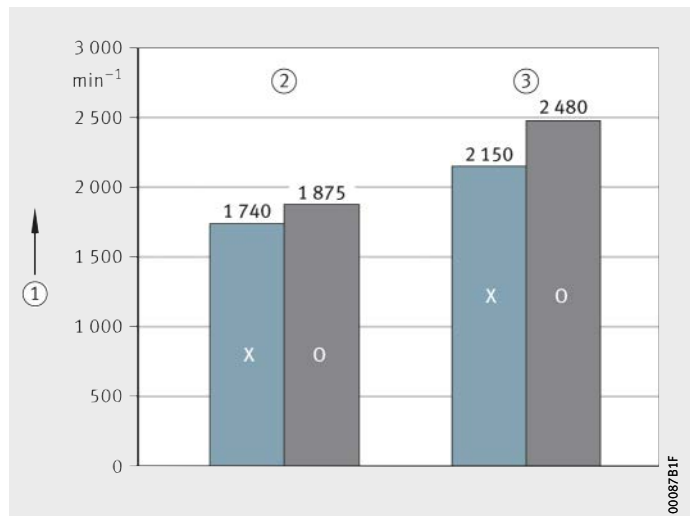

Axial angular contact ball bearings

Screw drive rigidity

The axial overall rigidity of the screw drive is of decisive importance for the machining accuracy and performance capability of machine tools. The axial system rigidity of a screw drive is heavily influenced by the design layout.

The highest axial system rigidity is achieved with the design “rotating screw drive nut”. In the design “rotating threaded spindle”, a significantly higher axial system rigidity is achieved with a locating/locating bearing arrangement on both sides and with increasing spindle length than with a locating/non-locating bearing arrangement, *Figure 37*.

- ① Axial overall rigidity
- ② Axial position of screw drive nut
- ③ Locating/locating bearing arrangement
- ④ Locating/non-locating bearing arrangement

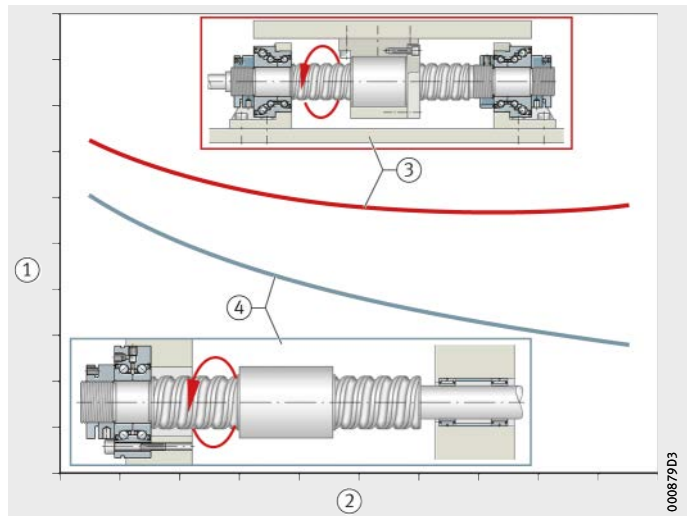

Figure 37

Axial overall rigidity

Locating bearing arrangement on one side

Locating bearing arrangement on one side for rotating threaded spindle, *Figure 38*:

- for short threaded spindles
- preconditions for use with longer threaded spindles:
 - low demands on axial system rigidity
 - sufficiently high critical whirling speed.

- ① Rotating threaded spindle

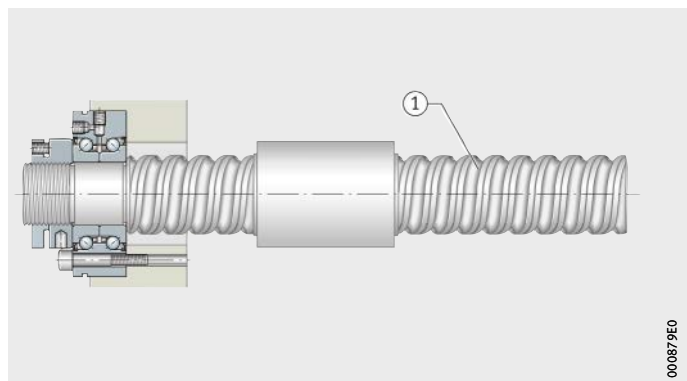

Figure 38

Locating bearing arrangement on one side

Locating/non-locating bearing arrangement

Locating/non-locating bearing arrangement for rotating threaded spindle, *Figure 39*:

- for longer threaded spindles
- low demands on axial system rigidity
- sufficiently high critical whirling speed of the threaded spindle
- if the tilting rigidity on the locating bearing side is increased by means of a second bearing, an increase in the critical whirling speed of the threaded spindle can be achieved in this bearing arrangement, *Figure 40*. As non-locating bearings, deep groove ball bearings or needle roller bearings are normally used.

① Rotating threaded spindle

Figure 39
Locating/non-locating bearing arrangement

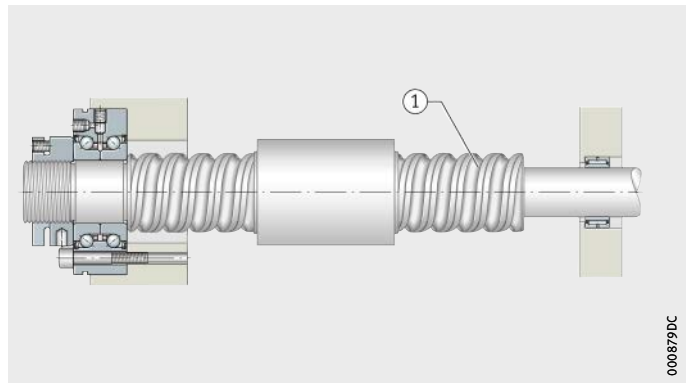

000879DC

① Rotating threaded spindle

Figure 40
Locating/non-locating bearing arrangement, higher tilting rigidity on non-locating bearing side

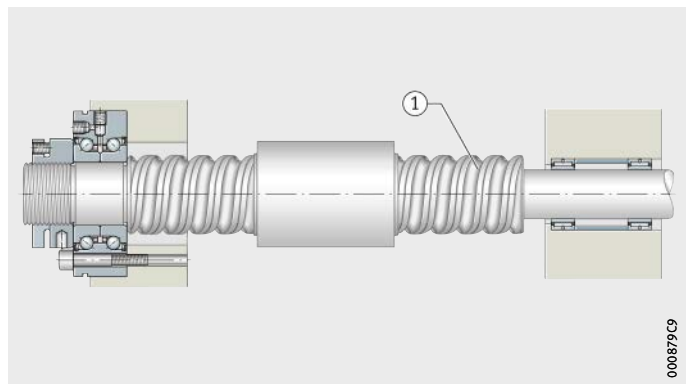

000879C9



Axial angular contact ball bearings

Locating/locating bearing arrangement

Locating/locating bearing arrangement for rotating threaded spindle, *Figure 41* and *Figure 42*:

- for medium length and long threaded spindles
- high axial system rigidity, *Figure 37*, page 40
- high critical whirling speed of the threaded spindle
- little effect of length changes under heating on the positioning.

Spindle firmly clamped on both sides with rotating screw drive nut, *Figure 43* and *Figure 44*, page 43:

- for long threaded spindles
- for highly dynamic screw drives
- increased spindle tensioning possible
- no influence of spindle tensioning on the bearing rating life.

- ① Rotating threaded spindle
- ② Locknut for preloading of bearing on left side
- ③ Locknut for tensioning of threaded spindle
- ④ Locknut for preloading of bearing on right side

Figure 41
Design example
Locating/locating
bearing arrangement,
tensioned spindle,
adjustment using locknut

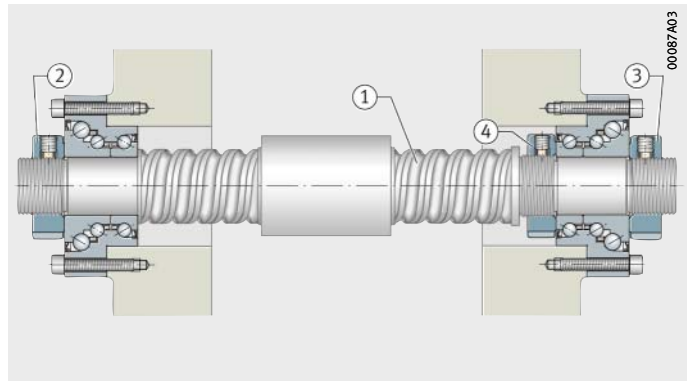

- ① Rotating threaded spindle
- ② Locknut for preloading of bearing on left side
- ③ Locknut for tensioning of threaded spindle
- ④ Shim

Figure 42
Design example
Locating/locating
bearing arrangement,
tensioned spindle,
adjustment using shim

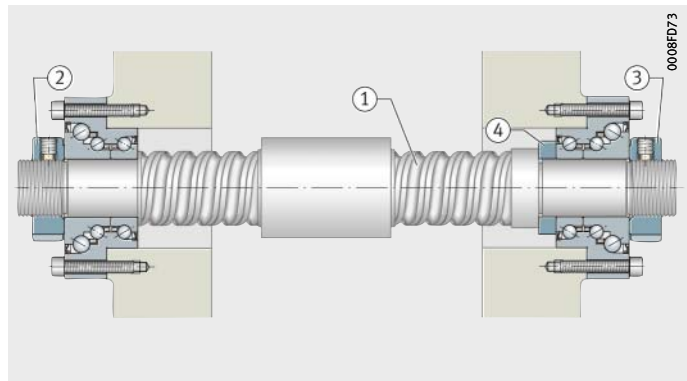

① Rotating screw drive nut

Figure 43
Design example,
rotating screw drive nut,
tensioned spindle

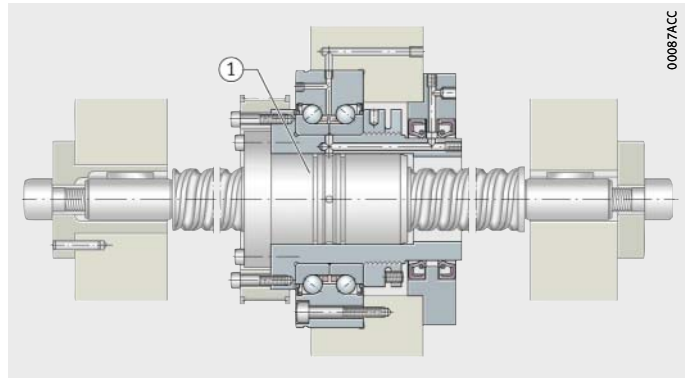

- ① Motor with toothed belt drive
- ② Hollow shaft motor as direct drive

Figure 44
Application examples,
rotating screw drive nut

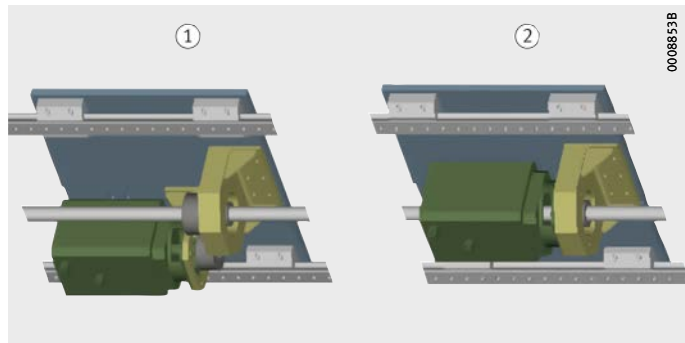

**Advantages
of a locating/locating
bearing arrangement**

In addition to axial rigidity, the dynamic characteristics of a screw drive are also important. A locating/locating bearing arrangement can be used to increase the critical whirling speed of the threaded spindle by up to 40% over a comparable locating/non-locating bearing arrangement.

A further aspect is the positional accuracy. If direct linear measuring systems are not used, a locating/locating bearing arrangement can be used to compensate the positional errors arising from spindle heating as long as the threaded spindle is in the tensioned state.

In the design of threaded spindles firmly clamped on both sides, tensioned and with a rotating screw drive nut, increased spindle tensioning is possible without this affecting the bearing rating life. As a result, particularly long threaded spindles with highly dynamic characteristics can be designed. For advice on and the preparation of mounting proposals, please make enquiries with Schaeffler.

Axial angular contact ball bearings

Design of a locating/locating bearing arrangement

Where there is a locating bearing arrangement on one side (with or without a non-locating bearing on the opposing side), the threaded spindle may undergo thermal expansion without this changing the load on the bearing position. This does not apply in the case of the locating/locating bearing arrangement.



In order to allow the described advantages of a locating bearing arrangement on both sides, some guidelines on design must be observed. If this is not done, it may lead to a reduced rating life or premature failure of the screw drive bearings.

Principles of a locating bearing arrangement on both sides

A locating bearing arrangement on both sides of a threaded spindle results in a statically overdefined system. In this case, the threaded spindle undergoes heating in operation and expands in length. This increase in length of the threaded spindle is, however, suppressed by the locating bearing arrangement on both sides, with the result that high compressive forces occur in the spindle. These can lead to buckling of the spindle and overloading of the screw drive bearings.

Tensioning of the threaded spindle

In order to avoid overloading of the screw drive bearings, threaded spindles with a locating bearing arrangement on both sides are elastically tensioned while they are cold. This is carried out during mounting by means of either a precision locknut and a calculated tightening torque, *Figure 41*, page 42, or a shim with a calculated adjustment gap, *Figure 42*, page 42.

The dimension for tensioning must be calculated for each application and is based on the expected mean operating temperature of the threaded spindle. The threaded spindle is tensioned while cold to at least the extent that no compressive forces will occur in the spindle when warm from operation. For design, either our calculation service or the free-of-charge calculation tool BEARINX-online accessible via an Internet connection can be used.

Highly dynamic or difficult-to-predict operating conditions

If considerable heating is present or the spindle operating conditions cannot be defined, tempering of the threaded spindle is necessary.

Alternatively, the design principle based on a rotating screw drive nut has proved effective. This is a technically high quality and high performance solution that allows higher tensioning forces to be used, since these do not have an effect on the bearing rating life, *Figure 43*, page 43.

In more economical solutions, the compressive forces occurring in the spindle change the function of the bearing arrangement to a locating/non-locating bearing arrangement. If the losses in terms of axial rigidity and critical whirling speed are accepted, this method allows economical prevention of total failure of the system, *Figure 46* and *Figure 47*, page 46.

Influence of the design on bearing rating life

Through tensioning of the spindle, the screw drive bearings are subjected to high load on one side while cold. In this case, the triple row axial angular contact ball bearings DKLFA are suitable, since these have particularly high load carrying capacity on one side.

The bearing rating life is directly dependent on the deviation between the assumed design temperature for spindle tensioning and the actual mean operating temperature of the threaded spindle, *Figure 45*.

The following statements can be derived as a result:

- Cold starting of the machine reduces the bearing rating life, since the spindle tensioning forces then apply a high degree of load to one side of the bearing positions.
- If the operating temperature actually present deviates too much from the operating temperature assumed for the design of spindle tensioning, this will reduce the bearing rating life.
- In applications where operating conditions are difficult to predict, unpredictably high heating of the threaded spindle can lead to compressive loading of the spindle with the risk of buckling.



L_{10h} = bearing rating life
 ΔT = deviation of actual operating temperature from design temperature

- ① Optimum operating range
- ② Cold, high spindle tensioning forces
- ③ Compressive load in threaded spindle

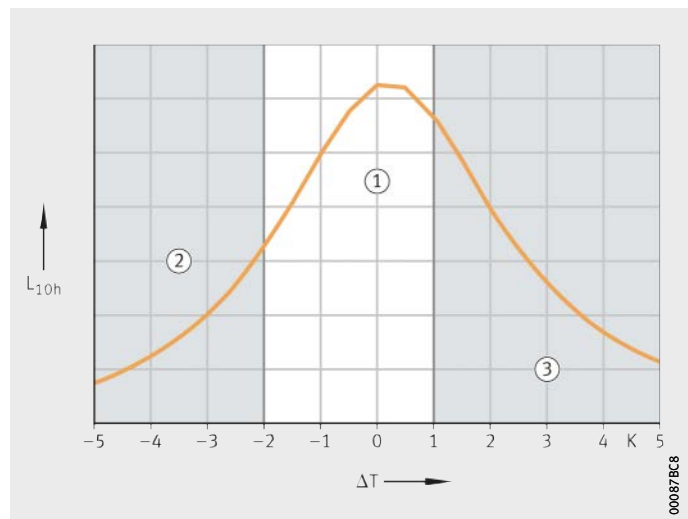

Figure 45
 Calculation of bearing rating life

Axial angular contact ball bearings

Economical overload protection in O arrangement

At one of the two bearing positions (generally the one opposing the drive), disc springs are added to the fixing screws and lightly preloaded with the screws, *Figure 46*. The screws are secured against loosening by means of suitable adhesive.

① Disc springs to DIN 2093; the quantity required must be calculated

Figure 46
Overload protection by means of disc springs (design example)

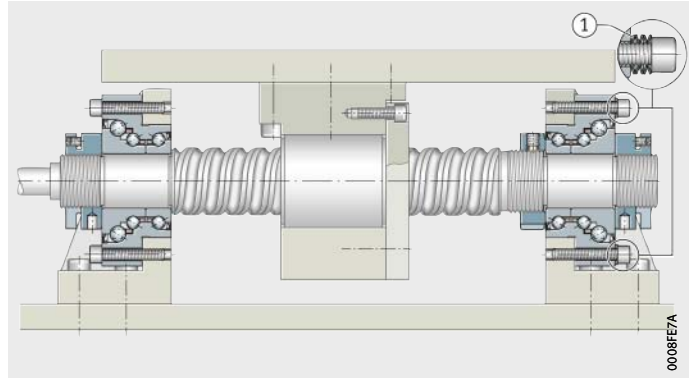

Economical overload protection in X arrangement

At one of the two bearing positions, the bearing seat on the shaft is designed as a sliding seat, *Figure 47*. If the spindle operating temperature changes within the scope of the design temperature for spindle tensioning, a locating/locating bearing arrangement is present. If higher temperatures occur, the spindle can expand without constraint, as a result of which the bearing arrangement becomes a locating/non-locating bearing arrangement. In order to prevent fretting corrosion at the sliding seat, suitable coatings such as hard chromium must be used.

① Sliding seat of bearing on shaft

Figure 47
Overload protection by means of sliding seat of bearing on shaft (design example)

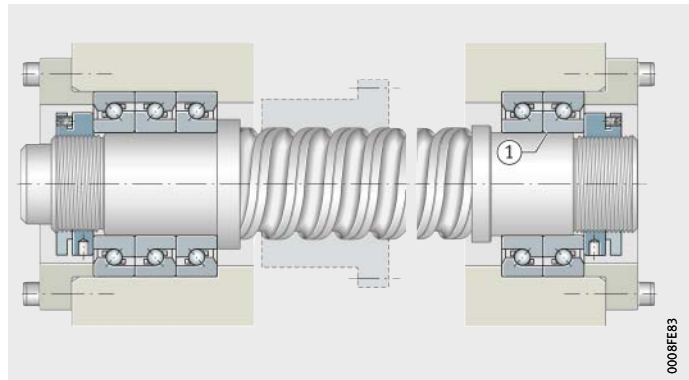

Design of adjacent construction



The adjacent construction (the shaft and housing) must be designed in accordance with the data in the dimension tables.

The abutment diameters for the shaft and housing shoulders d_a and D_a must be in accordance with the dimension tables.

D_a and d_a are recommended minimum abutment diameters. If these values are not used, the rib diameter d_1 according to the dimension table must be observed.

Pitch and quantity of fixing screws

The data in the dimension tables must be observed:

- For the axial angular contact ball bearings ZKLF for screw mounting, the dimension tables give both the quantity and pitch of the fixing screws for the bearing as well as the quantity and pitch of the required threaded fixing holes in the adjacent construction.
- In the case of the sizes of axial angular contact ball bearings ZKLF that are also available in the matched pair design 2AP, the individual bearings can have twice as many fixing holes in comparison with the adjacent construction. In these cases, the bearings are mounted leaving every second fixing hole unused.



For matched pairs of bearings

In matched pairs of axial angular contact ball bearings ZKLN and ZKLF, the depth of the housing bore must be defined such that the outer ring of the outermost bearing is radially supported to at least $1/4$ of its width.

The extraction slot for damage-free dismantling of the innermost bearing cannot be used, *Figure 48*, page 47. If the bearing is to be dismantled without damage, threaded extraction holes must be present in the screw mounting face of the adjacent construction.

ZKLF..-2AP

- ① Radial support
- ② Extraction slot not available for use
- ③ Thread optionally available as threaded extraction hole for damage-free bearing dismantling

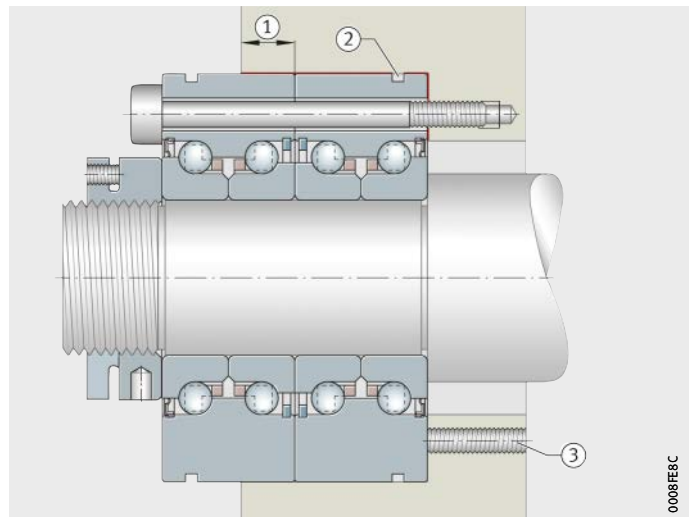

Figure 48
Design example of adjacent construction for ZKLF..-2AP

0008F8C

Axial angular contact ball bearings

Location of outer ring using ring nut for ZKLN, 7602, 7603, BSB

Axial angular contact ball bearings ZKLN, 7602, 7603 and BSB must be located clearance-free in the housing and on the shaft and must be axially preloaded during mounting. The axial preload force must be distributed evenly over the circumference in order to avoid deformation of the raceways.

Outer rings are axially tensioned to the preload force given in the dimension table by means of a ring nut (not included in the scope of delivery), *Figure 49*. The ring nut must be secured against loosening (for example using Loctite 638).

Ring nuts with an axial runout of max. 5 µm apply the preload force evenly over the bearing rings and should therefore be used in preference to location by means of a cover.

ZKLN, 7602, 7603, BSB

① Ring nut

Figure 49

2 bearing set in X arrangement, locknut AM, ring nut

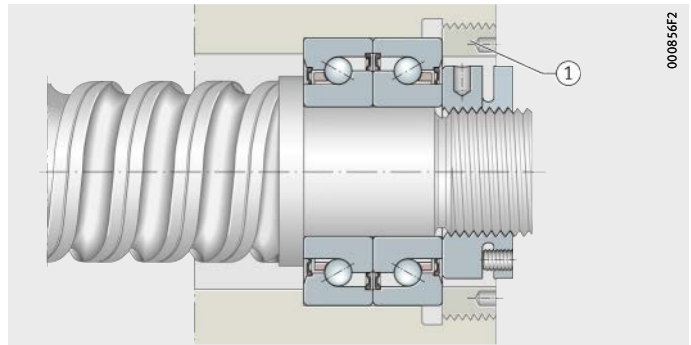

Location of outer ring using a cover

Clamping of the outer rings using a cover and cap screws leads to deformation of the raceways, *Figure 50*. In order to minimise the deformation and achieve the calculated rating life:

- The cover should be designed with adequate rigidity
- The number of fixing screws should be selected in accordance with the load but at least four should be used
- Tighten the screws in a cross-wise sequence in four stages (finger tight, 40%, 70%, 100% of M_A).



Observe the outer axial preload force in the dimension table. If other values are used, this will influence the bearing preload, bearing friction and heat generation in the bearing position.

ZKLN, 7602, 7603, BSB

① Cover

② Locknut

③ Gap before tightening of the cover fixing screws

Figure 50

2 bearing set in O arrangement, locknut AM, cover

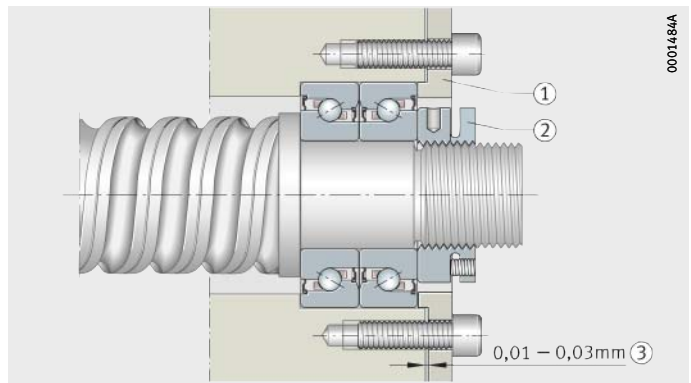

Radial centring of matched pairs of bearings ZKLF..-2AP screw mounted on a flat surface

Matched pairs of axial angular contact ball bearings ZKLF..-2AP screw mounted on a flat surface must be radially centred, *Figure 51*.

Radial centring of bearings

- ▶ Prepare a centring ring and push it over the joint between the two bearings. The ring must be in contact with the screw mounting face of the adjacent construction.
- ▶ Secure the ring axially using a commercially available retaining ring in the extraction groove of the bearing.

Dimensions of the ring

Guidelines on the dimensions of the ring, *Figure 52*:

- The dimensions D and d relate to the outside diameter D of the bearing, see dimension table.
- The width of the ring is the dimension l, see dimension table.

- ① Centring ring
- ② Retaining ring

Figure 51
Radial centring of matched pair of axial angular contact ball bearings ZKLF during mounting on face

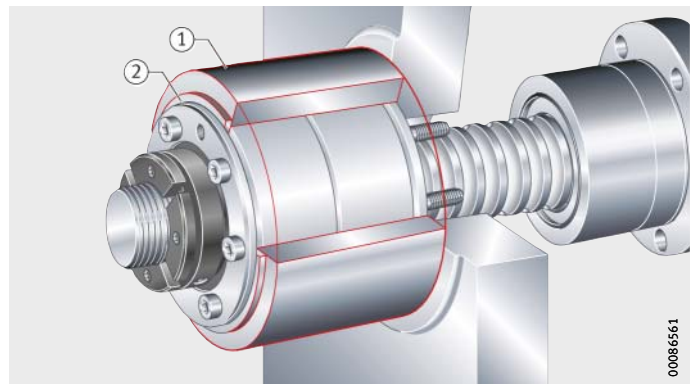
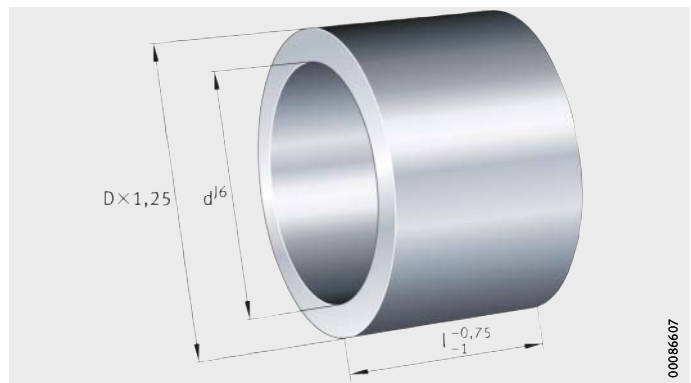

Figure 52
Dimensions of centring ring



Axial angular contact ball bearings

Screw mounting of triple row angular contact ball bearings

Triple row angular contact ball bearings DKLFA are located on the adjacent construction as follows, *Figure 53*:

- in the centring bore
- on the face and thus radially capable of radial alignment using the linear guidance system and screw drive as a datum.

DKLFA

- ① Bearing centred in adjacent construction
- ② Bearing capable of radial alignment

Figure 53
Mounting variants
of bearing unit DKLFA

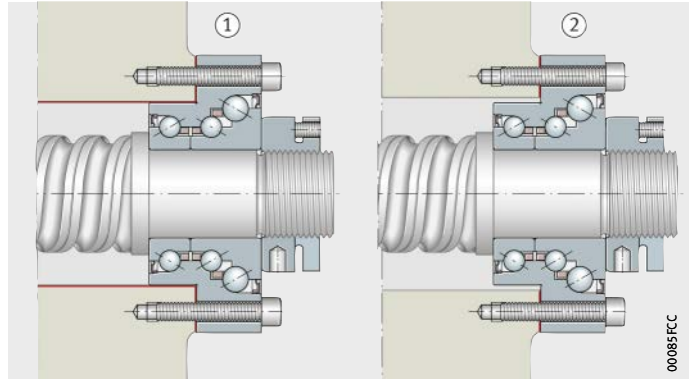

Speeds

The dimension tables give two different speed parameters:

- the maximum permissible limiting speed n_G
- the thermally safe operating speed n_{ϑ} for precision applications.

Limiting speed n_G

The limiting speed n_G is based on practical experience and test rig runs. It is the speed limit up to which the bearings can be operated as a maximum without kinematic processes in the rolling bearing leading to premature damage to the bearing. In bearings with contact seal lips 2RS, the speed is restricted by the seal material and its maximum permissible sliding velocity at the seal lip.

Under favourable environmental influences, higher limiting speeds can be achieved by using a bearing with minimal gap seals (suffix 2Z) instead of contact seals.

Thermally safe operating speed n_{ϑ}

The limiting speed n_G described allows heating of the bearing, which is generally undesirable for precision applications such as in machine tools. The guide value n_{ϑ} proven in practice for maximum speeds in machine tool applications is an empirical value at which, for an operating duration of max. 25% and without external operating loads, the bearing temperature is max. 50 °C. In this case, only the bearing preload is present.

If the environmental conditions are known, the equilibrium temperature to be anticipated at the bearing position can be determined by means of a thermal balance calculation.

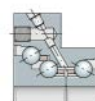

Axial angular contact ball bearings

Friction In most applications, preloading of bearings by means of the locknut tightening torque gives sufficiently accurate setting values. The reference here is the tightening torque M_A in accordance with the dimension tables in conjunction with an INA precision locknut. The bearing frictional torque M_R given in the dimension tables is a guide value for design of the drive. The actual values are generally lower. The values for bearing frictional torque relate in the case of axial angular contact ball bearings ZKLN, ZKLF, ZKLFA, DKLFA, 7602..-2RS, 7603..-2RS, BSB..-2RS and ZKLR to grease lubrication and are measured at a speed of $n = 5 \text{ min}^{-1}$ and at room temperature ($\vartheta = 20 \text{ °C}$).

In the case of open axial angular contact ball bearings 7602, 7603 and BSB, the bearing frictional torque M_R relates to lightly oiled raceways.

For dimensioning of the drive, the starting frictional torque and the frictional torque at high speeds in each case of $2 \cdot M_R$ to $3 \cdot M_R$ must be taken into consideration.

Seal friction In axial angular contact ball bearings with contact seals (suffix 2RS), the extent of seal friction cannot be disregarded. Sealing influences the limiting speeds and the heating of the bearing.

Frictional energy In any analysis of the thermal balance, the various operating speeds n_i must be taken into consideration with their time durations q_i .

The frictional energy N_R of the bearings can be calculated as follows:

$$N_R = \frac{M_R \cdot n}{9,55}$$

N_R	W
Frictional energy	
M_R	Nm
Bearing frictional torque	
n	min^{-1}
Operating speed.	

Lubrication Bearings for screw drives can be lubricated with grease or oil. In machine tools, however, the mean bearing temperature should not exceed +50 °C. If this is the case, a lubrication method without heat dissipation such as grease lubrication or oil impulse lubrication can be selected.



For higher bearing temperatures and open bearings, recirculating oil lubrication should be used.

Grease lubrication

Bearings with a relubrication facility of series ZKLN, ZKLF, ZKLFA and DKLFA are greased with a lithium soap grease GA28 and are preferably run with grease lubrication. In most cases, the initial greasing is sufficient for the operating life of the bearings. Under certain application conditions, relubrication may be necessary. In this case, Arcanol MULTITOP is suitable. The initial greasing is compatible with greases with a mineral oil base. For checking by calculation of the grease operating life, relubrication interval and relubrication quantity on the basis of a duty cycle (speed, load, operating duration, environmental conditions), please contact us.



Relubrication interval

The relubrication intervals cannot be determined precisely in advance. They are essentially dependent on the operating conditions and the environmental influences such as temperature, contamination, dust, water, etc.



Bearings must always be relubricated:

- before and after long stoppage periods
- in conditions of high humidity
- within the defined lubrication intervals as stated in the technical proposal letter.

For the following conditions, please contact us:

- stationary bearings
- vibrations
- very small oscillating movements.



Relubrication quantity

If axial angular contact ball bearings ZKLN, ZKLF, ZKLFA and DKLFA must be relubricated due to the application conditions, please contact us regarding the relubrication quantities.

Oil lubrication

Other lubrication methods such as oil impulse lubrication or recirculating oil lubrication are also possible. Oils CLP to DIN 51517-3 and HLP to DIN 51524-2 of ISO VG 32 to ISO VG 100 have proved effective for oil lubrication. If oil impulse lubrication is intended for axial angular contact ball bearings ZKLN and ZKLF, gap seals are advantageous. They prevent contamination entering the bearing and allow oil to leave the bearing. This prevents overlubrication.

Axial angular contact ball bearings

Mounting guidelines

Axial angular contact ball bearings are self-retaining and the individual bearing components are matched to each other. The inner rings must not be removed from the bearing during mounting and dismounting. If individual bearing components are removed from the bearing, please contact Schaeffler before carrying out any reassembly.

The characteristics of the bearings are only valid when used in combination with INA precision locknuts and the associated tightening torques given in the dimension tables.



During the mounting of bearings, mounting forces should be applied only to the bearing ring to be mounted. Mounting forces must never be directed through the rolling elements or sealing rings.

Bearings should only be mounted and dismounted in accordance with the Mounting and Maintenance Manual TPI 100.

Further information

- TPI 100, Bearings for Screw Drives, Mounting and Maintenance Manual
- Download and ordering: <http://medien.schaeffler.de>.

Location of inner ring using locknut

Axial angular contact ball bearings must be axially preloaded during mounting by means of a precision locknut.

The performance data given in the dimension tables are only valid if the specified preload forces are observed. The tightening torques for INA precision locknuts required for this purpose are also given in the dimension tables.

The tightening torques for the individual bearing sizes are only valid for the INA precision locknuts listed.

For locating/non-locating bearing arrangements and bearing arrangements for rotating ball screw drive nuts, the tightening torques can be taken directly from the dimension tables.

For locating/locating bearing arrangements, the value in the dimension table can only be used for the locknut ①, *Figure 54*, page 55, and *Figure 55*, page 55. For the other locknuts ② and ③, the tightening torques must be calculated using BEARINX, taking account of the application-specific design criteria.



Calculation can be carried out free of charge using BEARINX-online Easy BallScrew or can be requested. The tightening torques calculated must be observed.

Preventing settling

In order to counteract settling, the following tightening sequence must be observed:

- ▶ Tighten the precision locknut to twice the tightening torque M_A and then relieve the load again.
- ▶ Tighten the precision locknut to the stated tightening torque M_A .
- ▶ Secure the precision locknut against rotation by the torque-controlled tightening of the grub screws.



If other suitable locknuts are used, the manufacturer's guidance on calculation of the necessary tightening torque must be observed. Only use locknuts with a minimum radial runout accuracy of the end face to the thread of 5 μm .



- ① M_A taken from dimension table
- ②, ③ M_A calculated using BEARINX

Figure 54
Tightening torques of locknuts in locating/locating bearing arrangement for angular contact ball bearing units

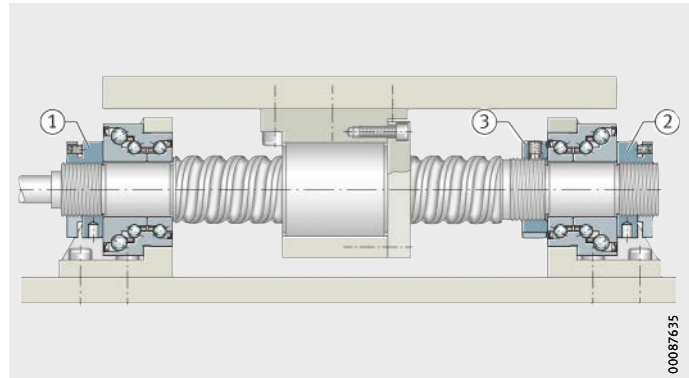

- ① M_A taken from dimension table
- ② M_A calculated using BEARINX

Figure 55
Tightening torques of locknuts in locating/locating bearing arrangement for single row axial angular contact ball bearings in X arrangement

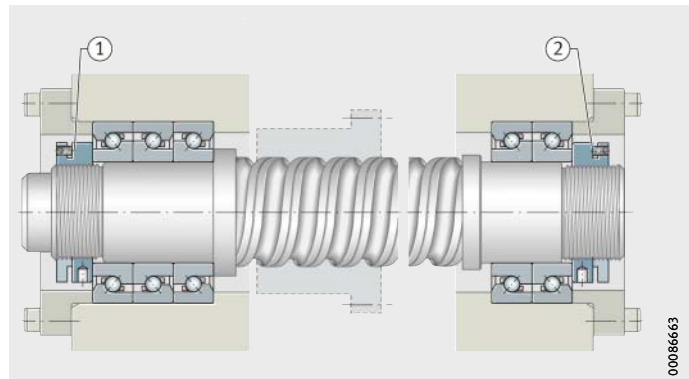

Mounting of angular contact ball bearing units

Angular contact ball bearing units ZKLR require no additional preload after mounting, see page 56. They can often therefore be located on the threaded spindle simply by means of clearance-free clamping, *Figure 57*.



The type of axial location depends on the load to be supported. The adjacent construction can be a milled flat face or, if necessary, even an unmachined screw mounting surface without radial centring.

ZKLR

- ① Bearing unit with locknut
- ② Threaded spindle
- ③ Tightening of fixing screws finger tight
- ④ Nut of screw drive
- ⑤ Tightening of fixing screws

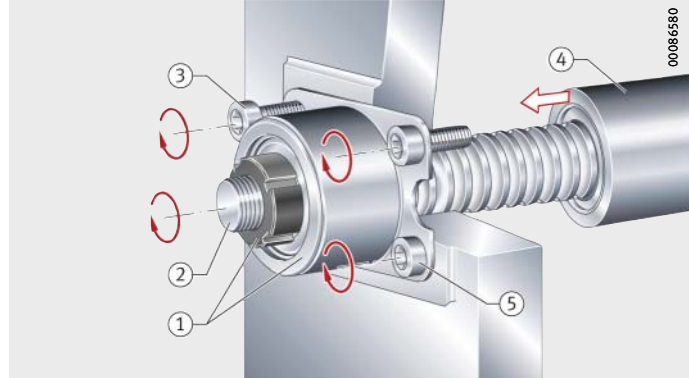

Figure 57
Mounting of bearing unit ZKLR

Axial angular contact ball bearings

Calculation example of screw drive bearing ZKLF30100-2Z-XL

Arrangements of screw drive bearings with a locating bearing arrangement on one side and a locating/non-locating bearing arrangement can be calculated, unless the bearing arrangement is subjected to tilting moment load, using either the following equations or with the calculation software BEARINX-online Easy BallScrew.

If a tilting moment load on the bearing arrangement is to be taken into consideration or statically overdefined systems such as arrangements with locating/locating bearings are involved, calculation must be carried out using the calculation program BEARINX. This also applies if, instead of the basic rating life L_{10h} , the expanded rating life L_{nm} is to be calculated. In this case, please consult Schaeffler or use the freely available program BEARINX-online Easy BallScrew:
<http://bearinx-online-easy-ballscrew.schaeffler.com>.

Given data

The given data for calculation of the rating life are as follows:

- arrangement of screw drive bearings with locating bearing arrangement on one side
- pure axial load.

- ① Locknut
- ② Axial angular contact ball bearing ZKLF30100-2Z-XL
- ③ Nut

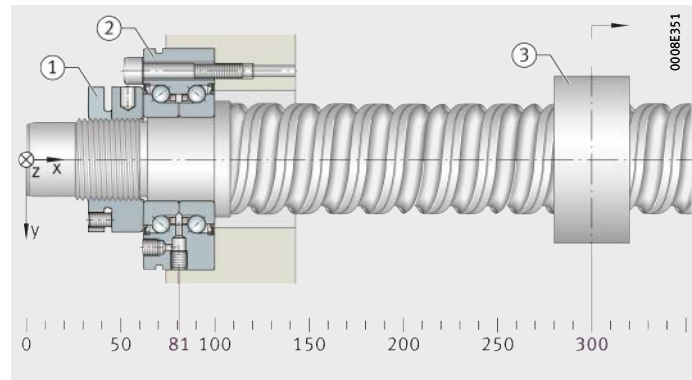

Figure 58 Specified screw drive bearing arrangement

Operating parameters

Operating temperature $\vartheta = +40\text{ °C}$
 Nominal viscosity at $+40\text{ °C}$ $\nu_{40} = 55\text{ mm}^2 \cdot \text{s}^{-1}$
 Life exponent for ball bearings $p = 3$
 Contamination factor $e_c = 0,5$
 (normal cleanliness)

Bearing data

Axial angular contact ball bearing = ZKLF30100-2Z-XL
 Basic dynamic load rating $C_a = 65\ 000$
 Basic static load rating $C_{0a} = 108\ 000$
 Fatigue limit load $C_u = 6\ 400\ \text{N}$

Required

- Expanded rating life.

Permissible limiting load

The checking of limiting loads is carried out with the aid of the diagrams for determining the resultant bearing load $F_{a\ res}$, see page 33.

The limiting load of 11 000 N taken from the diagrams is greater than the maximum operating load occurring $F_{aB\ max} = 10\ 500\ N$, which means that all the rows in the bearing are under preload at maximum load.

Static load safety factor S_0

The static load safety factor S_0 of the bearing should be ≥ 4 in machine tools. Under pure axial load, $P_0 = F_{a\ res} \approx 10\ 500\ N$.

$$S_0 = \frac{C_0}{P_0}$$

$$S_{0a} = \frac{108\ 000\ N}{10\ 500\ N} = 10,3$$

The result of the calculation shows that the static load safety factor is sufficiently high.

Dynamic forces due to the machining cycle

Calculation of the rating life L_{10h} is carried out using the values from the speed and load duty cycle, see table. The resultant bearing load $F_{a\ res}$ is determined from the diagram, *Figure 26*, page 34.

Speed and load spectrum for the machining cycle, dynamic values

Load case i	Time proportion q_i %	Speed n_i min^{-1}	Operating load F_{aB} N	Resultant bearing load N
1 rapid traverse	15	3 000	1 000	5 000
2 acceleration	15	1 500	10 500	10 500
3 rough machining	55	500	6 000	7 100
4 fine machining	15	100	1 000	5 000

Basic rating life

The basic rating life in millions of revolutions is the fatigue life reached or exceeded by 90% of a sufficiently large group of apparently identical bearings before the first evidence of material fatigue develops.

Equivalent bearing load

The equivalent bearing load for variation in steps is calculated as follows:

$$P = \sqrt[3]{\frac{q_1 \cdot n_1 \cdot P_1^3 + \dots + q_z \cdot n_z \cdot P_z^3}{q_1 \cdot n_1 + \dots + q_z \cdot n_z}}$$

$$P_a = \sqrt[3]{\frac{15 \cdot 3\ 000 \cdot 5\ 000^3 + 15 \cdot 1\ 500 \cdot 10\ 500^3 + \dots}{15 \cdot 3\ 000 + 15 \cdot 1\ 500 + \dots} + \frac{55 \cdot 500 \cdot 7\ 100^3 + 15 \cdot 100 \cdot 5\ 000^3}{55 \cdot 500 + 15 \cdot 100}} = 7\ 560\ N$$



Axial angular contact ball bearings

Equivalent speed

The equivalent speed for variation in steps is calculated as follows:

$$n = \frac{q_1 \cdot n_1 + q_2 \cdot n_2 + \dots + q_z \cdot n_z}{100}$$

$$n = \frac{15 \cdot 3\,000 + 15 \cdot 1\,500 + 55 \cdot 500 + 15 \cdot 100}{100} = 965 \text{ min}^{-1}$$

Rating life in revolutions

$$L_{10} = \left(\frac{C_a}{P_a} \right)^p$$

$$L_{10} = \left(\frac{65\,000}{7\,560} \right)^3 = 636 \cdot 10^6$$

Rating life in operating hours

$$L_{10h} = \frac{16\,666}{n} \cdot \left(\frac{C_a}{P_a} \right)^p$$

$$L_{10h} = \frac{16\,666}{965 \text{ min}^{-1}} \cdot \left(\frac{65\,000}{7\,560} \right)^3 = 10\,975 \text{ h}$$

Expanded rating life calculation

Calculation of the basic rating life L only takes into consideration the influence of load at the rolling contacts. In addition to the load, the lubrication regime and stress increases due to contamination of the lubricant also have a considerable influence on the fatigue life of a rolling bearing.

The method for calculating the adjusted rating life was fundamentally changed in 2007 with the revision of ISO 281.

The term “expanded rating life” was included for the first time in ISO 281:2010 and replaced the “adjusted rating life”.

Expanded rating life

$$L_{nm} = a_1 \cdot a_{ISO} \cdot L_{10}$$

Life adjustment factor a_{ISO}

The life adjustment factor a_{ISO} takes into consideration the lubrication regime, the contamination of the lubricant and the fatigue limit of the raceway material, *Figure 59*.

$$a_{ISO} = f \left[\frac{e_c \cdot C_U}{P}, \kappa \right]$$

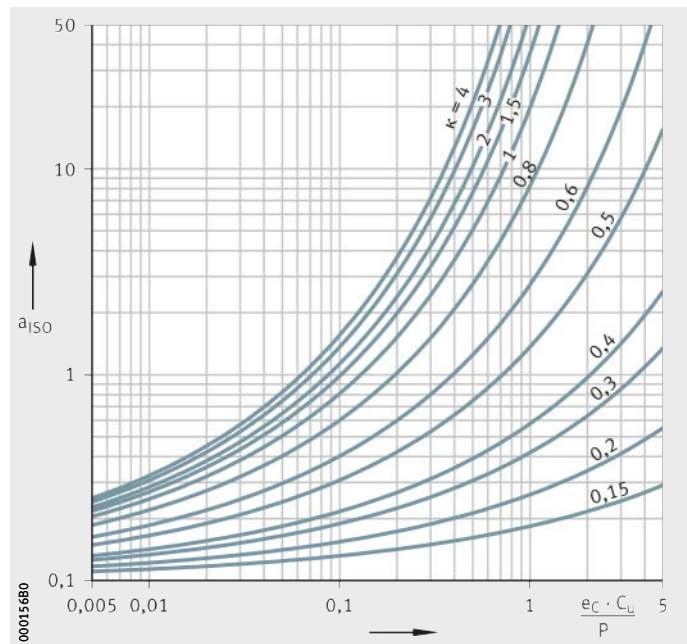

Figure 59
Life adjustment factor a_{ISO}
for axial ball bearings



Axial angular contact ball bearings

Calculation of the life adjustment factor a_{ISO} for load case 1

Based on the contamination factor $e_C = 0,5$ for normal cleanliness in accordance with ISO 281, the ratio $(e_C \cdot C_{u1})/P_1$ is determined first.

Based on the nominal viscosity $\nu_{40} = 55 \text{ mm}^2 \cdot \text{s}^{-1}$, the operating temperature $\vartheta = 40 \text{ }^\circ\text{C}$ and the mean bearing diameter $d_M = d_1$, the operating viscosity ν and the reference viscosity ν_1 are read from the diagrams, *Figure 60* and *Figure 61*, page 63.



If values $\kappa > 4$ are determined, calculation should be continued in accordance with ISO 281 using a viscosity ratio $\kappa = 4$. If $\kappa < 0,1$, the calculation is not valid. In this case, please consult Schaeffler.

Ratio $(e_C \cdot C_{u1})/P_1$

In conjunction with the fatigue limit load C_u and the equivalent load in load case 1, this gives:

$$\frac{e_C \cdot C_u}{P_1} = \frac{0,5 \cdot 6\,400 \text{ N}}{5\,000 \text{ N}} = 0,64$$

Viscosity ratio κ

The viscosity ratio $\kappa = \nu/\nu_1$ is calculated as follows:

$$\kappa = \frac{55 \text{ mm}^2 \cdot \text{s}^{-1}}{12 \text{ mm}^2 \cdot \text{s}^{-1}} = 4,6$$

ν/ϑ diagram for mineral oils

ν = operating viscosity
 ϑ = operating temperature
 ν_{40} = viscosity at +40 °C

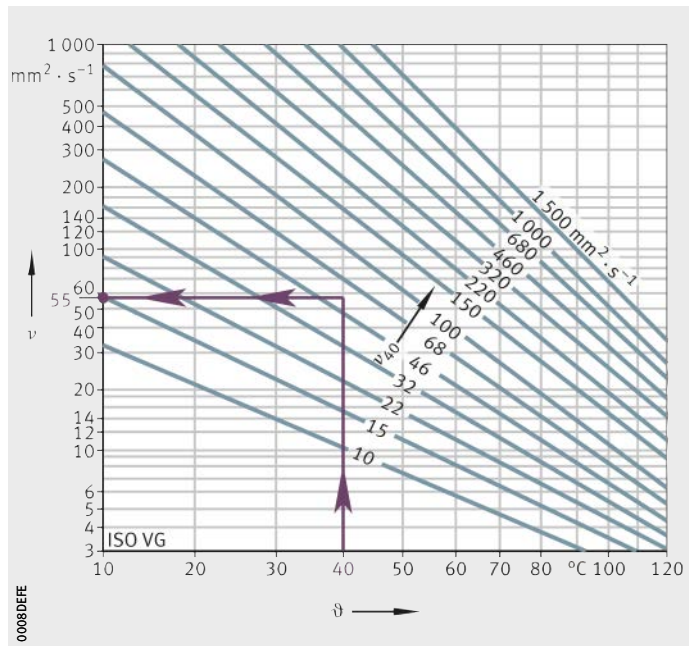

Figure 60

Calculation of operating viscosity ν at operating temperature ϑ

For ZKL30100:
 $d_M = d_1 = 51 \text{ mm}$

ν_1 = reference viscosity
 d_M = mean bearing diameter
 n = speed

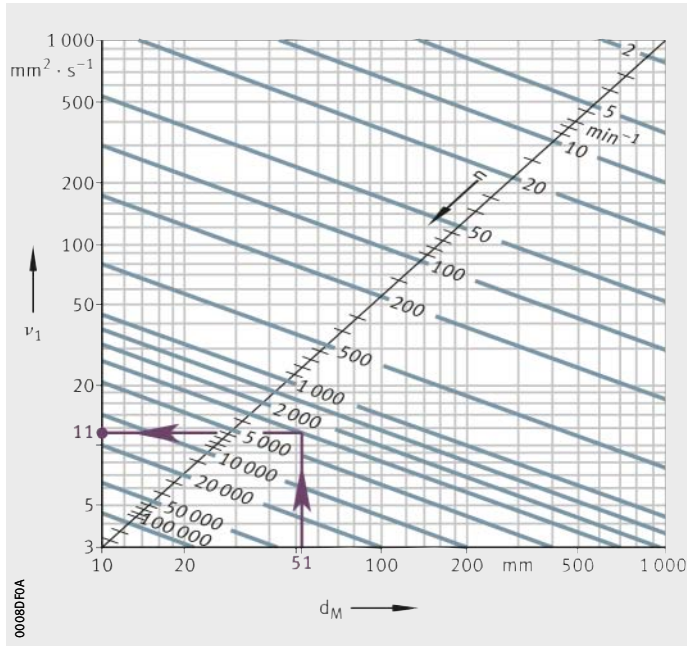

Figure 61
 Calculation of reference viscosity ν_1

**Life adjustment factors a_{ISO}
 for current operating condition**

Calculation of	Load case			
	1	2	3	4
$(e_C \cdot C_U) / P$	0,64	0,30	0,45	0,64
Operating viscosity ν	55	55	55	55
Reference viscosity ν_1	12	16	32	130
Viscosity ratio $\kappa = \nu / \nu_1$	(5) 4	3,4	1,7	0,4
Life adjustment factor a_{ISO}	a_1	a_2	a_3	a_4
	35	6,5	8,5	0,5

Axial angular contact ball bearings

Calculation of expanded rating life

Calculation of the expanded rating life incorporates not only the life adjustment factor a_{ISO} but also a life adjustment factor for the reliability a_1 . A reliability of 90% corresponds here to an achievable rating life with a commonly used, high quality material and under normal operating conditions that have proved sufficient over many years. In accordance with ISO 281, the life adjustment factor in this case is $a_1 = 1$.

Equivalent bearing load

The equivalent bearing load for a variation in steps is calculated, taking account of the life adjustment factors, as follows:

$$P = \sqrt[3]{\frac{\frac{1}{a_i} \cdot q_i \cdot n_i \cdot F_i^p + \dots + \frac{1}{a_z} \cdot q_z \cdot n_z \cdot F_z^p}{q_i \cdot n_i + \dots + q_z \cdot n_z}}$$

$$P_a = \sqrt[3]{\frac{\frac{1}{35} \cdot 15 \cdot 3\,000 \cdot 5\,000^3 + \frac{1}{6,5} \cdot 15 \cdot 1\,500 \cdot 10\,500^3}{15 \cdot 3\,000 + 15 \cdot 1\,500} + \dots + \frac{\frac{1}{8,5} \cdot 55 \cdot 500 \cdot 7\,100^3 + \frac{1}{0,5} \cdot 15 \cdot 100 \cdot 5\,000^3}{55 \cdot 500 + 15 \cdot 100}}$$

$$= 3\,895 \text{ N}$$

Expanded rating life

The rating life is calculated as follows, see page 60 and page 61:

$$L_{10m} = \frac{16\,666}{965 \text{ min}^{-1}} \cdot \left(\frac{65\,000 \text{ N}}{3\,895 \text{ N}} \right)^3 = 80\,264 \text{ h}$$

**Comparison
with BEARINX-online Easy BallScrew**

The catalogue calculation method in accordance with ISO 281 does not reflect the influence of bearing clearance, tilting or other influencing factors. As a result, deviations may arise compared to the more detailed calculation method in accordance with ISO/TS 16281, which is used in BEARINX-online.

In this example, calculation using BEARINX-online gives a minimum rating life $L_{h \min} = 64\,729$ h.

Calculation using BEARINX is not carried out with a static e_c value; the contamination factor is calculated for each load case in accordance with ISO 281. This gives a more accurate result in the rating life calculation.

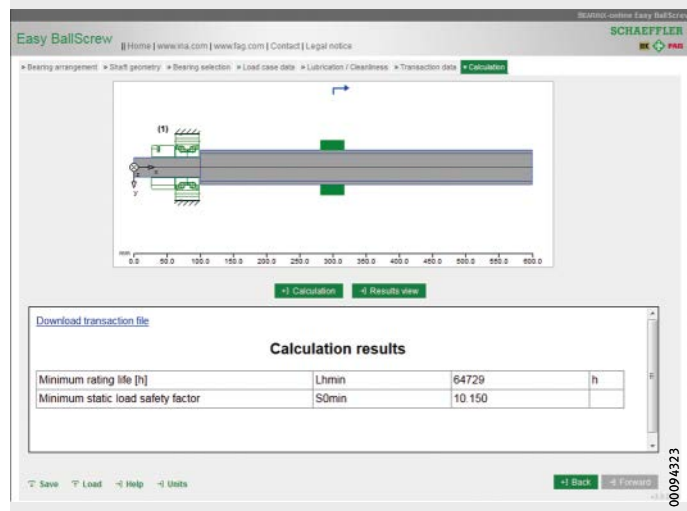
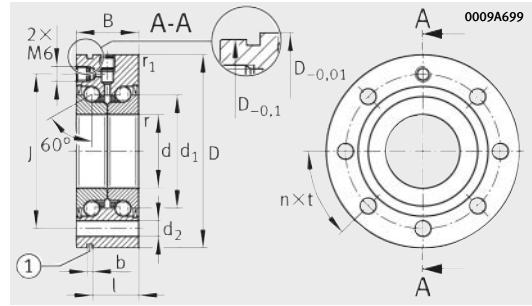

Figure 62
Calculation result
using BEARINX-online

Axial angular contact ball bearings

With fixing holes



ZKLF..-2RS, ZKLF..-2Z (d ≤ 50 mm)

Dimension table - Dimensions in mm

Designation	X-life	Mass m ≈ kg	Dimensions					
			d -0,005	D -0,01	B -0,25	d ₁	r min.	r ₁ min.
ZKLF1255-2RS	XL	0,37	12	55	25	25	0,3	0,6
ZKLF1255-2Z	XL	0,37	12	55	25	25	0,3	0,6
ZKLF1560-2RS	XL	0,43	15	60	25	28	0,3	0,6
ZKLF1560-2Z	XL	0,43	15	60	25	28	0,3	0,6
ZKLF1762-2RS	XL	0,45	17	62	25	30	0,3	0,6
ZKLF1762-2Z	XL	0,45	17	62	25	30	0,3	0,6
ZKLF2068-2RS	XL	0,61	20	68	28	34,5	0,3	0,6
ZKLF2068-2Z	XL	0,61	20	68	28	34,5	0,3	0,6

Performance data

Designation	X-life	Basic load ratings		Fatigue limit load C _u N	Limiting speed n _{G grease} min ⁻¹	Thermally safe operating speed n _θ min ⁻¹	Bearing frictional torque M _R Nm
		axial dyn. C _a N	stat. C _{0a} N				
ZKLF1255-2RS	XL	18 600	24 700	1 460	9 200	3 800	0,16
ZKLF1255-2Z	XL	18 600	24 700	1 460	12 000	7 600	0,08
ZKLF1560-2RS	XL	19 600	28 000	1 650	8 200	3 500	0,2
ZKLF1560-2Z	XL	19 600	28 000	1 650	10 800	7 000	0,1
ZKLF1762-2RS	XL	20 700	31 000	1 840	7 600	3 300	0,24
ZKLF1762-2Z	XL	20 700	31 000	1 840	10 100	6 600	0,12
ZKLF2068-2RS	XL	28 500	47 000	2 750	6 600	3 000	0,3
ZKLF2068-2Z	XL	28 500	47 000	2 750	8 700	5 400	0,15

① Extraction slot. ② Adjacent construction, bearing screw mounted on flat surface. ③ Adjacent construction, bearing screw mounted in bore. ④ Only valid in assembled condition.

- 1) The screws are not included in the scope of delivery. Tightening torque in accordance with manufacturer's data. Number of holes in adjacent construction corresponds to t_a.
- 2) Based on rotating inner ring.
- 3) The recommended INA precision locknuts are not included in the scope of delivery and must be ordered separately.
- 4) The required axial locknut force must be observed when using other locknuts.
- 5) Only valid in conjunction with INA precision locknuts. Note the guidelines on locating/locating bearing arrangements, see page 54.

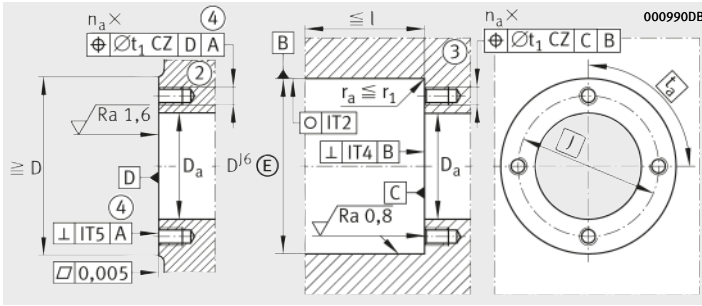

Housing design

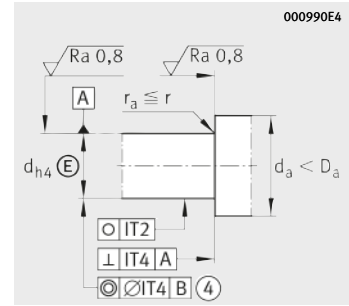

Shaft design
(threaded spindle)

				Pitch $n \times t$	Mounting dimensions			Fixing screws ¹⁾ DIN EN ISO 4762 10.9	
J	d_2	b	l		D_a max.	d_a min.	t_1	Size	$n_a \times t_a$
42	6,8	3	17	$3 \times 120^\circ$	33	16	0,1	M6	$3 \times 120^\circ$
42	6,8	3	17	$3 \times 120^\circ$	33	16	0,1	M6	$3 \times 120^\circ$
46	6,8	3	17	$3 \times 120^\circ$	35	20	0,1	M6	$3 \times 120^\circ$
46	6,8	3	17	$3 \times 120^\circ$	35	20	0,1	M6	$3 \times 120^\circ$
48	6,8	3	17	$6 \times 60^\circ$	37	23	0,1	M6	$3 \times 120^\circ$
48	6,8	3	17	$6 \times 60^\circ$	37	23	0,1	M6	$3 \times 120^\circ$
53	6,8	3	19	$8 \times 45^\circ$	43	25	0,1	M6	$4 \times 90^\circ$
53	6,8	3	19	$8 \times 45^\circ$	43	25	0,1	M6	$4 \times 90^\circ$

Rigidity axial c_{aL} N/ μm	Tilting rigidity c_{kL}	Mass moment of inertia ²⁾ M_m	Axial runout ²⁾ μm	Recommended INA precision locknut ³⁾			Required locknut force ⁴⁾ axial N
				For radial locking	For axial locking	Tightening torque ⁵⁾ M_A Nm	
375	50	0,068	2	ZM12	–	8	5 307
375	50	0,068	2	ZM12	–	8	5 307
400	65	0,102	2	ZM15	AM15	10	5 484
400	65	0,102	2	ZM15	AM15	10	5 484
450	80	0,132	2	ZM17	AM17	15	7 514
450	80	0,132	2	ZM17	AM17	15	7 514
650	140	0,273	2	ZM20	AM20	18	8 258
650	140	0,273	2	ZM20	AM20	18	8 258



Axial angular contact ball bearings

With fixing holes

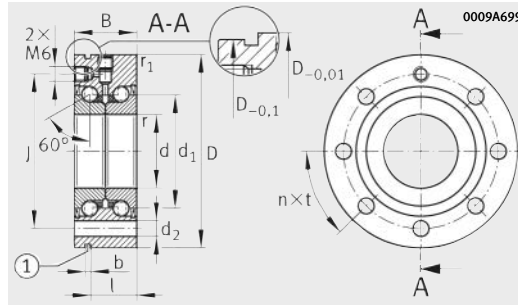

ZKLF...-2RS, ZKLF...-2Z (d ≤ 50 mm)

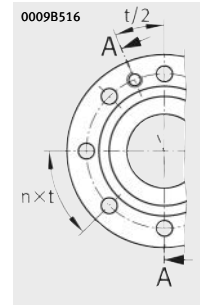

ZKLF30100

Dimension table (continued) · Dimensions in mm

Designation	X-life	Mass m ≈ kg	Dimensions					
			d -0,005	D -0,01	B -0,25	d ₁	r min.	r ₁ min.
ZKLF2575-2RS	XL	0,72	25	75	28	40,5	0,3	0,6
ZKLF2575-2Z	XL	0,72	25	75	28	40,5	0,3	0,6
ZKLF3080-2RS	XL	0,78	30	80	28	45,5	0,3	0,6
ZKLF3080-2Z	XL	0,78	30	80	28	45,5	0,3	0,6
ZKLF30100-2RS ²⁾	XL	1,63	30	100	38	51	0,3	0,6
ZKLF30100-2Z ²⁾	XL	1,63	30	100	38	51	0,3	0,6
ZKLF3590-2RS	XL	1,13	35	90	34	52	0,3	0,6
ZKLF3590-2Z	XL	1,13	35	90	34	52	0,3	0,6

Performance data

Designation	X-life	Basic load ratings		Fatigue limit load C _u N	Limiting speed n _{G grease} min ⁻¹	Thermally safe operating speed n _θ min ⁻¹	Bearing frictional torque M _R Nm
		dyn. C _a N	stat. C _{0a} N				
ZKLF2575-2RS	XL	30 500	55 000	3 250	5 700	2 600	0,4
ZKLF2575-2Z	XL	30 500	55 000	3 250	7 500	4 700	0,2
ZKLF3080-2RS	XL	32 000	64 000	3 750	5 000	2 200	0,5
ZKLF3080-2Z	XL	32 000	64 000	3 750	6 700	4 300	0,25
ZKLF30100-2RS ²⁾	XL	65 000	108 000	6 400	4 500	2 100	0,8
ZKLF30100-2Z ²⁾	XL	65 000	108 000	6 400	5 600	4 000	0,4
ZKLF3590-2RS	XL	45 000	89 000	5 200	4 400	2 000	0,6
ZKLF3590-2Z	XL	45 000	89 000	5 200	5 800	3 800	0,3

① Extraction slot. ② Adjacent construction, bearing screw mounted on flat surface. ③ Adjacent construction, bearing screw mounted in bore. ④ Only valid in assembled condition.

1) The screws are not included in the scope of delivery. Tightening torque in accordance with manufacturer's data. Number of holes in adjacent construction corresponds to t_a.

2) Heavy series.

3) Based on rotating inner ring.

4) The recommended INA precision locknuts are not included in the scope of delivery and must be ordered separately.

5) The required axial locknut force must be observed when using other locknuts.

6) Only valid in conjunction with INA precision locknuts.

Note the guidelines on locating/locating bearing arrangements, see page 54.

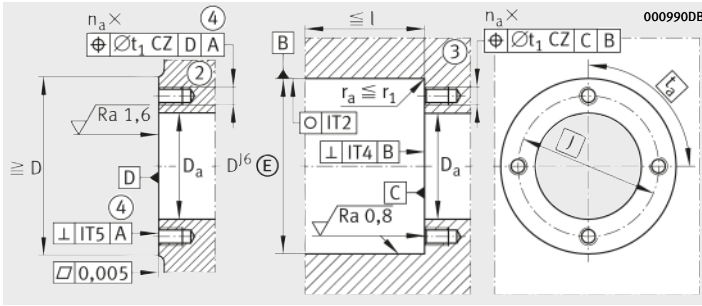

Housing design

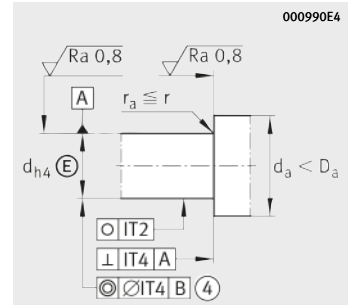

Shaft design
(threaded spindle)

				Pitch $n \times t$	Mounting dimensions			Fixing screws ¹⁾ DIN EN ISO 4762 10.9	
J	d_2	b	l		D_a max.	d_a min.	t_1	Size	$n_a \times t_a$
58	6,8	3	19	$8 \times 45^\circ$	48	32	0,1	M6	$4 \times 90^\circ$
58	6,8	3	19	$8 \times 45^\circ$	48	32	0,1	M6	$4 \times 90^\circ$
63	6,8	3	19	$12 \times 30^\circ$	53	40	0,1	M6	$6 \times 60^\circ$
63	6,8	3	19	$12 \times 30^\circ$	53	40	0,1	M6	$6 \times 60^\circ$
80	8,8	3	30	$8 \times 45^\circ$	64	47	0,2	M8	$8 \times 45^\circ$
80	8,8	3	30	$8 \times 45^\circ$	64	47	0,2	M8	$8 \times 45^\circ$
75	8,8	3	25	$8 \times 45^\circ$	62	45	0,2	M8	$4 \times 90^\circ$
75	8,8	3	25	$8 \times 45^\circ$	62	45	0,2	M8	$4 \times 90^\circ$

Rigidity axial c_{aL} N/ μm	Tilting rigidity c_{kL}	Mass moment of inertia ³⁾ M_m	Axial runout ³⁾ μm	Recommended INA precision locknut ⁴⁾			Required locknut force ⁵⁾ axial N
				For radial locking	For axial locking	Tightening torque ⁶⁾ M_A Nm	
750	200	0,486	2	ZM25	AM25	25	9 123
750	200	0,486	2	ZM25	AM25	25	9 123
850	300	0,73	2,5	ZM30	AM30	32	9 947
850	300	0,73	2,5	ZM30	AM30	32	9 947
950	400	1,91	2,5	ZMA30/52	AM30	65	19 509
950	400	1,91	2,5	ZMA30/52	AM30	65	19 509
900	400	1,51	2,5	ZM35	AM35/58	40	10 770
900	400	1,51	2,5	ZM35	AM35/58	40	10 770



Axial angular contact ball bearings

With fixing holes

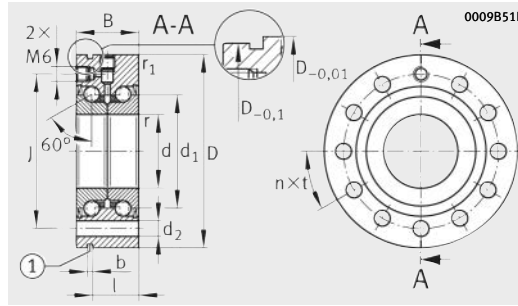

ZKLF...-2RS, ZKLF...-2Z (d ≤ 50 mm)

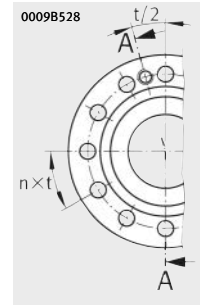

ZKLF40115
ZKLF50140

Dimension table (continued) · Dimensions in mm

Designation	X-life	Mass m ≈ kg	Dimensions					
			d -0,005	D -0,01	B -0,25	d ₁	r min.	r ₁ min.
ZKLF40100-2RS	XL	1,46	40	100	34	58	0,3	0,6
ZKLF40100-2Z	XL	1,46	40	100	34	58	0,3	0,6
ZKLF40115-2RS ²⁾	XL	2,2	40	115	46	65	0,6	0,6
ZKLF40115-2Z ²⁾	XL	2,2	40	115	46	65	0,6	0,6
ZKLF50115-2RS	XL	1,86	50	115	34	72	0,3	0,6
ZKLF50115-2Z	XL	1,86	50	115	34	72	0,3	0,6
ZKLF50140-2RS ²⁾	XL	4,7	50	140	54	80	0,6	0,6
ZKLF50140-2Z ²⁾	XL	4,7	50	140	54	80	0,6	0,6

Performance data

Designation	X-life	Basic load ratings		Fatigue limit load C _u N	Limiting speed n _G grease min ⁻¹	Thermally safe operating speed n _θ min ⁻¹	Bearing frictional torque M _R Nm
		axial dyn. C _a N	stat. C _{0a} N				
ZKLF40100-2RS	XL	47 500	101 000	6 000	4 000	1 800	0,7
ZKLF40100-2Z	XL	47 500	101 000	6 000	5 200	3 300	0,35
ZKLF40115-2RS ²⁾	XL	79 000	149 000	8 800	3 500	1 600	1,3
ZKLF40115-2Z ²⁾	XL	79 000	149 000	8 800	4 400	3 100	0,65
ZKLF50115-2RS	XL	51 000	126 000	7 400	3 200	1 500	0,9
ZKLF50115-2Z	XL	51 000	126 000	7 400	4 200	3 000	0,45
ZKLF50140-2RS ²⁾	XL	125 000	250 000	14 800	2 900	1 200	2,6
ZKLF50140-2Z ²⁾	XL	125 000	250 000	14 800	3 500	2 500	1,3

① Extraction slot. ② Adjacent construction, bearing screw mounted on flat surface. ③ Adjacent construction, bearing screw mounted in bore. ④ Only valid in assembled condition.

- 1) The screws are not included in the scope of delivery. Tightening torque in accordance with manufacturer's data. Number of holes in adjacent construction corresponds to t_a.
- 2) Heavy series.
- 3) Based on rotating inner ring.
- 4) The recommended INA precision locknuts are not included in the scope of delivery and must be ordered separately.
- 5) The required axial locknut force must be observed when using other locknuts.
- 6) Only valid in conjunction with INA precision locknuts. Note the guidelines on locating/locating bearing arrangements, see page 54.

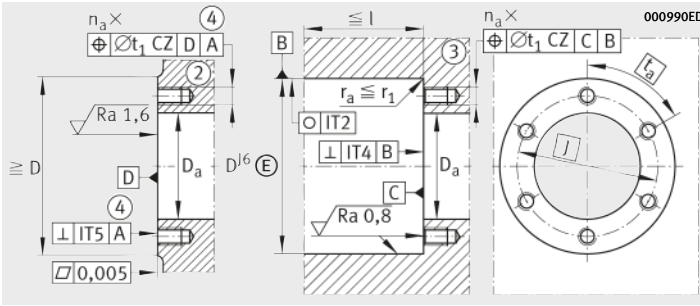

Housing design

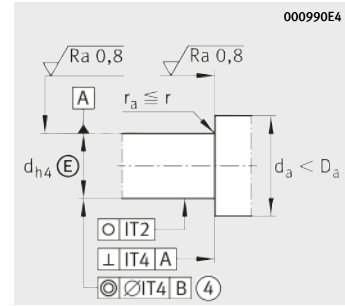

Shaft design
(threaded spindle)

J	d ₂	b	l	Pitch n×t	Mounting dimensions			Fixing screws ¹⁾ DIN EN ISO 4762 10.9	
					D _a max.	d _a min.	t ₁	Size	n _a ×t _a
80	8,8	3	25	8×45°	67	50	0,2	M8	4×90°
80	8,8	3	25	8×45°	67	50	0,2	M8	4×90°
94	8,8	3	36	12×30°	80	56	0,2	M8	12×30°
94	8,8	3	36	12×30°	80	56	0,2	M8	12×30°
94	8,8	3	25	12×30°	82	63	0,2	M8	6×60°
94	8,8	3	25	12×30°	82	63	0,2	M8	6×60°
113	11	3	45	12×30°	98	63	0,2	M10	12×30°
113	11	3	45	12×30°	98	63	0,2	M10	12×30°

Rigidity axial c _{aL} N/μm	Tilting rigidity c _{kL}	Mass moment of inertia ³⁾ M _m	Axial runout ³⁾ μm	Recommended INA precision locknut ⁴⁾			Required locknut force ⁵⁾ axial N
				For radial locking	For axial locking	Tightening torque ⁶⁾ M _A Nm	
1000	550	2,26	2,5	ZM40	AM40	55	13 412
1000	550	2,26	2,5	ZM40	AM40	55	13 412
1200	750	5,5	2,5	ZMA40/62	AM40	110	25 185
1200	750	5,5	2,5	ZMA40/62	AM40	110	25 815
1250	1000	5,24	2,5	ZM50	AM50	85	16 280
1250	1000	5,24	2,5	ZM50	AM50	85	16 280
1400	1500	15,2	2,5	ZMA50/75	AM50	150	28 451
1400	1500	15,2	2,5	ZMA50/75	AM50	150	28 451



Axial angular contact ball bearings

With fixing holes

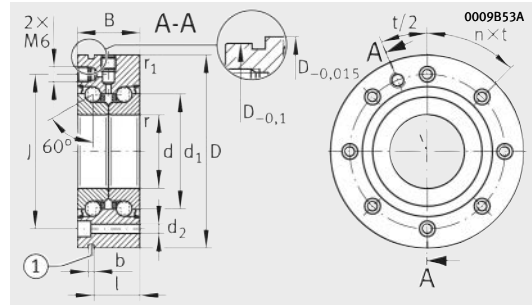

ZKLF...-2Z (60 mm ≤ d ≤ 100 mm)

Dimension table (continued) · Dimensions in mm

Designation	X-life	Mass m ≈ kg	Dimensions					
			d -0,008	D -0,015	B -0,25	d ₁	r min.	r ₁ min.
ZKLF60145-2Z	XL	4,3	60	145	45	85	0,6	0,6
ZKLF70155-2Z	XL	4,9	70	155	45	95	0,6	0,6
ZKLF80165-2Z	XL	5,3	80	165	45	105	0,6	0,6
ZKLF90190-2Z	XL	8,7	90	190	55	120	0,6	0,6
ZKLF100200-2Z	XL	9,3	100	200	55	132	0,6	0,6
ZKLF100230-2Z	-	17,6	100	230	85	146	0,6	0,6

Performance data

Designation	X-life	Basic load ratings axial		Fatigue limit load C _u N	Limiting speed n _{G grease} min ⁻¹	Thermally safe operating speed n _ø min ⁻¹	Bearing frictional torque M _R Nm
		dyn. C _a N	stat. C _{0a} N				
ZKLF60145-2Z	XL	93 000	214 000	12 600	4 000	3 000	1
ZKLF70155-2Z	XL	97 000	241 000	14 200	3 800	2 800	1,2
ZKLF80165-2Z	XL	100 000	265 000	15 400	3 600	2 700	1,4
ZKLF90190-2Z	XL	149 000	395 000	21 300	3 500	2 300	2,3
ZKLF100200-2Z	XL	154 000	435 000	22 400	3 300	2 150	2,6
ZKLF100230-2Z	-	295 000	790 000	29 000	2 900	2 000	3

① Extraction slot. ② Adjacent construction, bearing screw mounted on flat surface. ③ Adjacent construction, bearing screw mounted in bore. ④ Only valid in assembled condition.

- 1) The screws are not included in the scope of delivery. Tightening torque in accordance with manufacturer's data. Number of holes in adjacent construction corresponds to t_a.
- 2) Based on rotating inner ring.
- 3) The recommended INA precision locknuts are not included in the scope of delivery and must be ordered separately.
- 4) The required axial locknut force must be observed when using other locknuts.
- 5) Only valid in conjunction with INA precision locknuts. Note the guidelines on locating/locating bearing arrangements, see page 54.

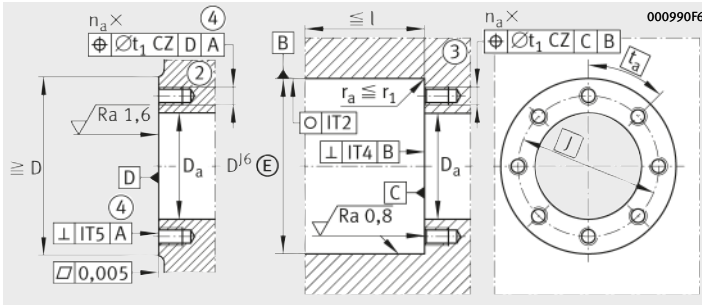

Housing design

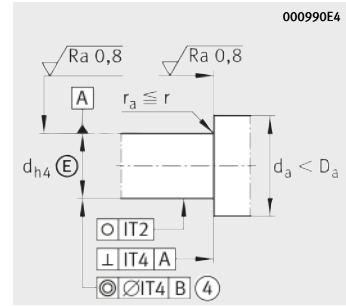

Shaft design
(threaded spindle)

J	d ₂	b	l	Pitch n×t	Mounting dimensions			Fixing screws ¹⁾ DIN EN ISO 4762 10.9	
					D _a max.	d _a min.	t ₁	Size	n _a ×t _a
120	8,8	3	35	8×45°	100	82	0,2	M8	8×45°
130	8,8	3	35	8×45°	110	92	0,2	M8	8×45°
140	8,8	3	35	8×45°	120	102	0,2	M8	8×45°
165	11	3	45	8×45°	138	116	0,2	M10	8×45°
175	11	3	45	8×45°	150	128	0,2	M10	8×45°
200	14	3	73	12×30°	175	130	0,4	M12	12×30°

Rigidity axial	Tilting rigidity	Mass moment of inertia ²⁾	Axial runout ²⁾	Recommended INA precision locknut ³⁾			Required locknut force ⁴⁾
				For radial locking	For axial locking	Tightening torque ⁵⁾	
c _{aL}	c _{kL}	M _m	μm			M _A	axial
N/μm						Nm	N
1300	1650	13,7	3	ZMA60/98	AM60	100	16 700
1450	2250	19,8	3	ZMA70/110	AM70	130	19 031
1600	3000	27,6	3	ZMA80/120	AM80	160	20 604
1700	4400	59,9	3	ZMA90/130	AM90	200	22 731
1900	5800	85,3	3	ZMA100/140	AM100	250	25 624
2450	8200	185	3	–	AM100	500	52 000



Axial angular contact ball bearings

With fixing holes
Less stringent tolerances

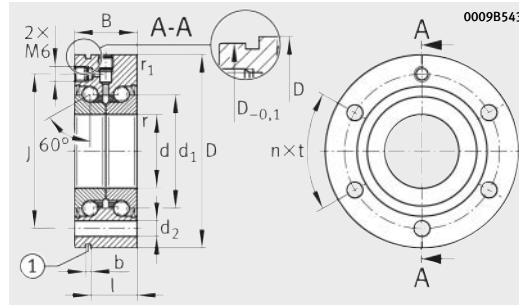

ZKLF..-2RS-PE

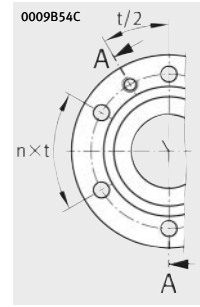

ZKLF12, ZKLF15

Dimension table - Dimensions in mm

Designation	Mass m ≈ kg	Dimensions					
		d -0,01	D	B -0,25	d ₁	r min.	r ₁ min.
ZKLF1255-2RS-PE	0,37	12	55 _{-0,013}	25	25	0,3	0,6
ZKLF1560-2RS-PE	0,43	15	60 _{-0,013}	25	28	0,3	0,6
ZKLF1762-2RS-PE	0,45	17	62 _{-0,013}	25	30	0,3	0,6
ZKLF2068-2RS-PE	0,61	20	68 _{-0,013}	28	34,5	0,3	0,6
ZKLF2575-2RS-PE	0,72	25	75 _{-0,013}	28	40,5	0,3	0,6
ZKLF3080-2RS-PE	0,78	30	80 _{-0,013}	28	45,5	0,3	0,6
ZKLF3590-2RS-PE	1,13	35	90 _{-0,015}	34	52	0,3	0,6
ZKLF40100-2RS-PE	1,46	40	100 _{-0,015}	34	58	0,3	0,6
ZKLF50115-2RS-PE	1,86	50	115 _{-0,015}	34	72	0,3	0,6

Performance data

Designation	Basic load ratings		Fatigue limit load C _u N	Limiting speed n _{G grease} min ⁻¹	Thermally safe operating speed n _{th} min ⁻¹	Bearing frictional torque M _R Nm
	axial dyn. C _a N	stat. C _{0a} N				
ZKLF1255-2RS-PE	16 900	24 700	1 090	9 200	3 800	0,16
ZKLF1560-2RS-PE	17 900	28 000	1 240	8 200	3 500	0,2
ZKLF1762-2RS-PE	18 800	31 000	1 380	7 600	3 300	0,24
ZKLF2068-2RS-PE	26 000	47 000	2 070	6 600	3 000	0,3
ZKLF2575-2RS-PE	27 500	55 000	2 450	5 700	2 600	0,4
ZKLF3080-2RS-PE	29 000	64 000	2 800	5 000	2 200	0,5
ZKLF3590-2RS-PE	41 000	89 000	3 950	4 400	2 000	0,6
ZKLF40100-2RS-PE	43 000	101 000	4 450	4 000	1 800	0,7
ZKLF50115-2RS-PE	46 500	126 000	5 600	3 200	1 500	0,9

① Extraction slot. ② Adjacent construction, bearing screw mounted on flat surface. ③ Adjacent construction, bearing screw mounted in bore. ④ Only valid in assembled condition.

- The screws are not included in the scope of delivery. Tightening torque in accordance with manufacturer's data. Number of holes in adjacent construction corresponds to t_a.
- Based on rotating inner ring.
- The recommended INA precision locknuts are not included in the scope of delivery and must be ordered separately.
- The required axial locknut force must be observed when using other locknuts.
- Only valid in conjunction with INA precision locknuts.
Note the guidelines on locating/locating bearing arrangements, see page 54.

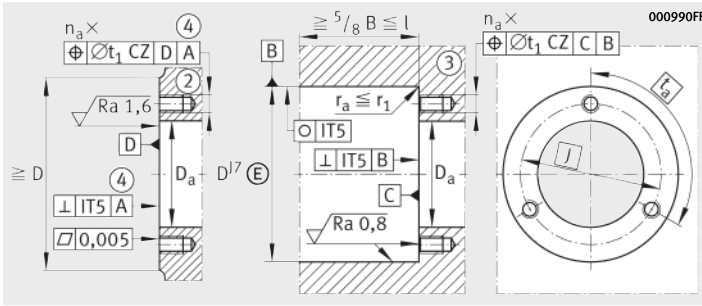

Housing design

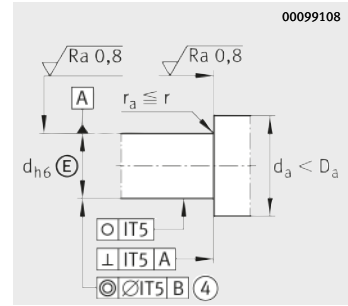

Shaft design
(threaded spindle)

J	d ₂	b	l	Pitch n×t	Mounting dimensions			Fixing screws ¹⁾ DIN EN ISO 4762 10.9	
					D _a max.	d _a min.	t ₁	Size	n _a ×t _a
42	6,8	3	17	3×120°	33	16	0,1	M6	3×120°
46	6,8	3	17	3×120°	35	20	0,1	M6	3×120°
48	6,8	3	17	6×60°	37	23	0,1	M6	3×120°
53	6,8	3	19	8×45°	43	25	0,1	M6	4×90°
58	6,8	3	19	8×45°	48	32	0,1	M6	4×90°
63	6,8	3	19	12×30°	53	40	0,1	M6	6×60°
75	8,8	3	25	8×45°	62	45	0,2	M8	4×90°
80	8,8	3	25	8×45°	67	50	0,2	M8	4×90°
94	8,8	3	25	12×30°	82	63	0,2	M8	6×60°

Rigidity axial c _{aL} N/μm	Tilting rigidity c _{kL}	Mass moment of inertia ²⁾ M _m	Axial runout ²⁾ μm	Recommended INA precision locknut ³⁾			Required locknut force ⁴⁾ axial N
				For radial locking	For axial locking	Tightening torque ⁵⁾ M _A Nm	
375	50	0,068	5	ZM12	–	8	5 307
400	65	0,102	5	ZM15	AM15	10	5 484
450	80	0,132	5	ZM17	AM17	15	7 514
650	140	0,273	5	ZM20	AM20	18	8 258
750	200	0,486	5	ZM25	AM25	25	9 123
850	300	0,73	5	ZM30	AM30	32	9 947
900	400	1,51	5	ZM35	AM35/58	40	10 770
1 000	550	2,26	5	ZM40	AM40	55	13 412
1 250	1 000	5,24	5	ZM50	AM50	85	16 280

Axial angular contact ball bearings

With fixing holes
Matched pair

X-life

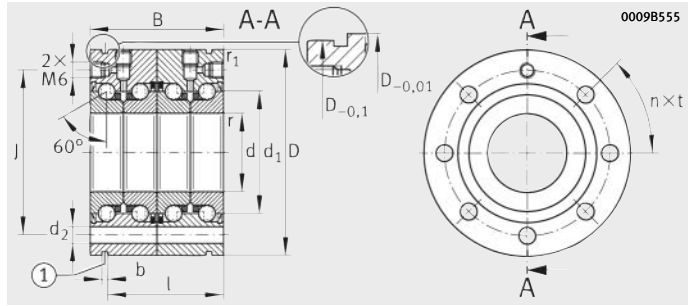

ZKLF.-2RS-2AP

Dimension table - Dimensions in mm

Designation	X-life	Mass m ≈ kg	Dimensions					
			d -0,005	D -0,01	B -0,25	d ₁	r min.	r ₁ min.
ZKLF1762-2RS-2AP	XL	0,9	17	62	50	30	0,3	0,6
ZKLF2068-2RS-2AP	XL	1,22	20	68	56	34,5	0,3	0,6
ZKLF2575-2RS-2AP	XL	1,44	25	75	56	40,5	0,3	0,6
ZKLF3080-2RS-2AP	XL	1,56	30	80	56	45,5	0,3	0,6
ZKLF3590-2RS-2AP	XL	2,26	35	90	68	52	0,3	0,6
ZKLF40100-2RS-2AP	XL	2,92	40	100	68	58	0,3	0,6
ZKLF50115-2RS-2AP	XL	3,72	50	115	68	72	0,3	0,6

Performance data

Designation	X-life	Basic load ratings axial		Fatigue limit load C _u N	Limiting speed n _{G grease} min ⁻¹	Thermally safe operating speed n _θ min ⁻¹	Bearing frictional torque M _R Nm
		dyn. C _a N	stat. C _{0a} N				
ZKLF1762-2RS-2AP	XL	33 500	62 000	3 700	7 600	3 300	0,36
ZKLF2068-2RS-2AP	XL	46 000	94 000	5 500	6 600	3 000	0,45
ZKLF2575-2RS-2AP	XL	49 000	111 000	6 500	5 700	2 600	0,6
ZKLF3080-2RS-2AP	XL	52 000	127 000	7 500	5 000	2 200	0,75
ZKLF3590-2RS-2AP	XL	73 000	177 000	10 500	4 400	2 000	0,9
ZKLF40100-2RS-2AP	XL	77 000	202 000	11 900	4 000	1 800	1,05
ZKLF50115-2RS-2AP	XL	83 000	250 000	14 900	3 200	1 500	1,35

Further sizes and designs with seals Z2 available by agreement.

① Extraction slot. ② Adjacent construction, bearing screw mounted on flat surface. ③ Adjacent construction, bearing screw mounted in bore. ④ Only valid in assembled condition. ⑤ Threaded extraction holes, see page 47.

- The screws are not included in the scope of delivery. Tightening torque in accordance with manufacturer's data. Number of holes in adjacent construction corresponds to t_a.
- Based on rotating inner ring.
- The recommended INA precision locknuts are not included in the scope of delivery and must be ordered separately.
- The required axial locknut force must be observed when using other locknuts.
- Only valid in conjunction with INA precision locknuts. Note the guidelines on locating/locating bearing arrangements, see page 54.

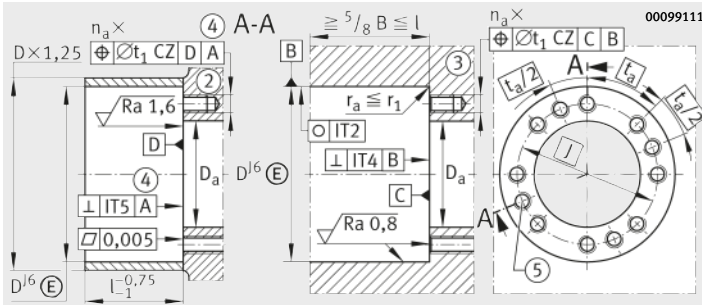

Housing design

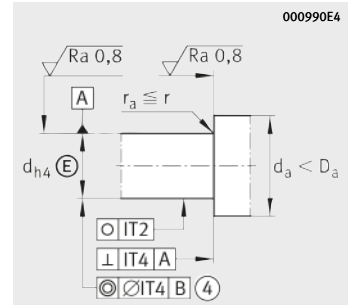

Shaft design
(threaded spindle)

J	d ₂	b	l	Pitch n×t	Mounting dimensions			Fixing screws ¹⁾ DIN EN ISO 4762 10.9	
					D _a max.	d _a min.	t ₁	Size	n _a ×t _a
48	6,8	3	42	6×60°	37	23	0,1	M6×60	6×60°
53	6,8	3	47	8×45°	43	25	0,1	M6×70	8×45°
58	6,8	3	47	8×45°	48	32	0,1	M6×70	8×45°
63	6,8	3	47	12×30°	53	40	0,1	M6×70	12×30°
75	8,8	3	59	8×45°	62	45	0,2	M8×80	8×45°
80	8,8	3	59	8×45°	67	50	0,2	M8×80	8×45°
94	8,8	3	59	12×30°	82	63	0,2	M8×80	12×30°

Rigidity axial c _{aL} N/μm	Tilting rigidity c _{kL}	Mass moment of inertia ²⁾ M _m	Axial runout ²⁾ μm	Recommended INA precision locknut ³⁾			Required locknut force ⁴⁾ axial N
				For radial locking	For axial locking	Tightening torque ⁵⁾ M _A Nm	
800	200	0,264	2	ZM17	AM17	15	7 514
1 150	320	0,564	2	ZMA20/38	AM20	18	8 258
1 300	450	0,972	2	ZMA25/45	AM25	25	9 123
1 500	620	1,46	2,5	ZMA30/52	AM30	32	9 947
1 600	900	3,02	2,5	ZMA35/58	AM35/58	40	10 770
1 750	1 200	4,52	2,5	ZMA40/62	AM40	55	13 412
2 200	2 250	10,48	2,5	ZMA50/75	AM50	85	16 280

Axial angular contact ball bearings

Without fixing holes

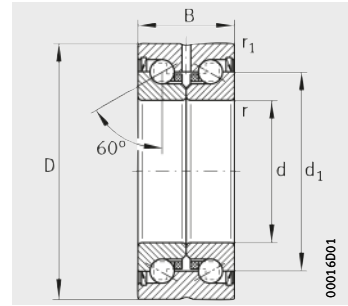

ZKLN...-2RS, ZKLN...-2Z

X-life

Dimension table - Dimensions in mm

Designation	X-life	Mass m ≈ kg	Dimensions						Mounting dimensions		Basic load ratings axial		Fatigue limit load C _u N
			d	D	B	d ₁	r	r ₁	D _a	d _a	dyn. C _a N	stat. C _{0a} N	
ZKLN0619-2Z ⁵⁾	XL	0,02	6 ^{+0,002} _{-0,003}	19	12	12	0,3	0,3	16	9	5 400	6 100	360
ZKLN0624-2RS	XL	0,03	6 ^{+0,002} _{-0,003}	24	15	14	0,3	0,6	19	9	7 600	8 500	500
ZKLN0624-2Z	XL	0,03	6 ^{+0,002} _{-0,003}	24	15	14	0,3	0,6	19	9	7 600	8 500	500
ZKLN0832-2RS	XL	0,09	8 ^{+0,005} _{-0,005}	32	20	19	0,3	0,6	26	11	13 800	16 300	960
ZKLN0832-2Z	XL	0,09	8 ^{+0,005} _{-0,005}	32	20	19	0,3	0,6	26	11	13 800	16 300	960
ZKLN1034-2RS	XL	0,1	10 ^{+0,005} _{-0,005}	34	20	21	0,3	0,6	28	14	14 700	18 800	1 110
ZKLN1034-2Z	XL	0,1	10 ^{+0,005} _{-0,005}	34	20	21	0,3	0,6	28	14	14 700	18 800	1 110
ZKLN1242-2RS	XL	0,2	12 ^{+0,005} _{-0,005}	42	25	25	0,3	0,6	33	16	18 600	24 700	1 460
ZKLN1242-2Z	XL	0,2	12 ^{+0,005} _{-0,005}	42	25	25	0,3	0,6	33	16	18 600	24 700	1 460
ZKLN1545-2RS	XL	0,21	15 ^{+0,005} _{-0,005}	45	25	28	0,3	0,6	35	20	19 600	28 000	1 650
ZKLN1545-2Z	XL	0,21	15 ^{+0,005} _{-0,005}	45	25	28	0,3	0,6	35	20	19 600	28 000	1 650
ZKLN1747-2RS	XL	0,22	17 ^{+0,005} _{-0,005}	47	25	30	0,3	0,6	37	23	20 700	31 000	1 840
ZKLN1747-2Z	XL	0,22	17 ^{+0,005} _{-0,005}	47	25	30	0,3	0,6	37	23	20 700	31 000	1 840
ZKLN2052-2RS	XL	0,31	20 ^{+0,005} _{-0,005}	52	28	34,5	0,3	0,6	43	25	28 500	47 000	2 750
ZKLN2052-2Z	XL	0,31	20 ^{+0,005} _{-0,005}	52	28	34,5	0,3	0,6	43	25	28 500	47 000	2 750
ZKLN2557-2RS	XL	0,34	25 ^{+0,005} _{-0,005}	57	28	40,5	0,3	0,6	48	32	30 500	55 000	3 250
ZKLN2557-2Z	XL	0,34	25 ^{+0,005} _{-0,005}	57	28	40,5	0,3	0,6	48	32	30 500	55 000	3 250
ZKLN3062-2RS	XL	0,39	30 ^{+0,005} _{-0,005}	62	28	45,5	0,3	0,6	53	40	32 000	64 000	3 750
ZKLN3062-2Z	XL	0,39	30 ^{+0,005} _{-0,005}	62	28	45,5	0,3	0,6	53	40	32 000	64 000	3 750
ZKLN3072-2RS ⁶⁾	XL	0,72	30 ^{+0,005} _{-0,005}	72	38	51	0,3	0,6	64	47	65 000	108 000	6 400
ZKLN3072-2Z ⁶⁾	XL	0,72	30 ^{+0,005} _{-0,005}	72	38	51	0,3	0,6	64	47	65 000	108 000	6 400
ZKLN3572-2RS	XL	0,51	35 ^{+0,005} _{-0,005}	72	34	52	0,3	0,6	62	45	45 000	89 000	5 200
ZKLN3572-2Z	XL	0,51	35 ^{+0,005} _{-0,005}	72	34	52	0,3	0,6	62	45	45 000	89 000	5 200

④ Only valid in assembled condition.

1) Based on rotating inner ring.

2) The recommended INA precision locknuts are not included in the scope of delivery and must be ordered separately.

3) The required axial locknut force must be observed when using other locknuts.

4) Only valid in conjunction with INA precision locknuts.

Note the guidelines on locating/locating bearing arrangements, see page 54.

5) No relubrication facility.

6) Heavy series.

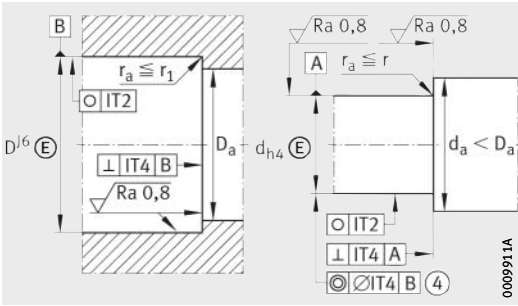

Design of housing and shaft (threaded spindle)

Limiting speed	Thermally safe operating speed	Bearing frictional torque	Rigidity axial	Tilting rigidity	Mass moment of inertia ¹⁾	Axial runout ¹⁾	Recommended INA precision locknut ²⁾			Required locknut force ³⁾ axial
							For radial locking	For axial locking	Tightening torque ⁴⁾	
n_G grease min^{-1}	n_{th} min^{-1}	M_R Nm	c_{aL} $\text{N}/\mu\text{m}$	c_{kL} Nm/mrad	M_m $\text{kg} \cdot \text{cm}^2$	μm			M_A Nm	N
22 800	14 000	0,01	150	4	0,0019	2	ZM06	–	1	2 010
16 400	6 800	0,04	200	8	0,0044	2	ZM06	–	2	2 404
19 900	12 000	0,02	200	8	0,0044	2	ZM06	–	2	2 404
12 100	5 100	0,08	250	20	0,02	2	ZM08	–	4	3 468
15 500	9 500	0,04	250	20	0,02	2	ZM08	–	4	3 468
10 900	4 600	0,12	325	25	0,029	2	ZM10	–	6	4 891
14 400	8 600	0,06	325	25	0,029	2	ZM10	–	6	4 891
9 200	3 800	0,16	375	50	0,068	2	ZM12	–	8	5 307
12 000	7 600	0,08	375	50	0,068	2	ZM12	–	8	5 307
8 200	3 500	0,2	400	65	0,102	2	ZM15	AM15	10	5 484
10 800	7 000	0,1	400	65	0,102	2	ZM15	AM15	10	5 484
7 600	3 300	0,24	450	80	0,132	2	ZM17	AM17	15	7 514
10 100	6 600	0,12	450	80	0,132	2	ZM17	AM17	15	7 514
6 600	3 000	0,3	650	140	0,273	2	ZM20	AM20	18	8 258
8 700	5 400	0,15	650	140	0,273	2	ZM20	AM20	18	8 258
5 700	2 600	0,4	750	200	0,486	2	ZM25	AM25	25	9 123
7 500	4 700	0,2	750	200	0,486	2	ZM25	AM25	25	9 123
5 000	2 200	0,5	850	300	0,73	2,5	ZM30	AM30	32	9 947
6 700	4 300	0,25	850	300	0,73	2,5	ZM30	AM30	32	9 947
4 500	2 100	0,8	950	400	1,91	2,5	ZMA30/52	AM30	65	19 509
5 600	4 000	0,4	950	400	1,91	2,5	ZMA30/52	AM30	65	19 509
4 400	2 000	0,6	900	400	1,51	2,5	ZM35	AM35/58	40	10 770
5 800	3 800	0,3	900	400	1,51	2,5	ZM35	AM35/58	40	10 770



Axial angular contact ball bearings

Without fixing holes

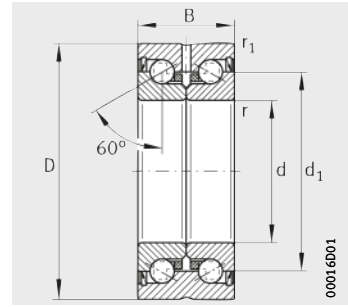

ZKLN...-2RS, ZKLN...-2Z

Dimension table (continued) · Dimensions in mm

Designation	X-life	Mass m ≈ kg	Dimensions						Mounting dimensions		Basic load ratings axial		Fatigue limit load C _u N
			d	D	B	d ₁	r	r ₁	D _a max.	d _a min.	dyn. C _a N	stat. C _{0a} N	
ZKLN4075-2RS	XL	0,61	40 ^{-0,005}	75 ^{-0,01}	34	58	0,3	0,6	67	50	47 500	101 000	6 000
ZKLN4075-2Z	XL	0,61	40 ^{-0,005}	75 ^{-0,01}	34	58	0,3	0,6	67	50	47 500	101 000	6 000
ZKLN4090-2RS ⁵⁾	XL	0,95	40 ^{-0,005}	90 ^{-0,01}	46	65	0,6	0,6	80	56	79 000	149 000	8 800
ZKLN4090-2Z ⁵⁾	XL	0,95	40 ^{-0,005}	90 ^{-0,01}	46	65	0,6	0,6	80	56	79 000	149 000	8 800
ZKLN5090-2RS	XL	0,88	50 ^{-0,005}	90 ^{-0,01}	34	72	0,3	0,6	82	63	51 000	126 000	7 400
ZKLN5090-2Z	XL	0,88	50 ^{-0,005}	90 ^{-0,01}	34	72	0,3	0,6	82	63	51 000	126 000	7 400
ZKLN50110-2RS ⁵⁾	XL	2,5	50 ^{-0,005}	110 ^{-0,01}	54	80	0,6	0,6	98	63	125 000	250 000	14 800
ZKLN50110-2Z ⁵⁾	XL	2,5	50 ^{-0,005}	110 ^{-0,01}	54	80	0,6	0,6	98	63	125 000	250 000	14 800
ZKLN60110-2Z	XL	2,2	60 ^{-0,008}	110 ^{-0,015}	45	85	0,6	0,6	100	82	93 000	214 000	12 600
ZKLN70120-2Z	XL	2,4	70 ^{-0,008}	120 ^{-0,015}	45	95	0,6	0,6	110	92	97 000	241 000	14 200
ZKLN80130-2Z	XL	2,7	80 ^{-0,008}	130 ^{-0,015}	45	105	0,6	0,6	120	102	100 000	265 000	15 400
ZKLN90150-2Z	XL	4,5	90 ^{-0,008}	150 ^{-0,015}	55	120	0,6	0,6	138	116	149 000	395 000	21 300
ZKLN100160-2Z	XL	4,9	100 ^{-0,008}	160 ^{-0,015}	55	132	0,6	0,6	150	128	154 000	435 000	22 400

④ Only valid in assembled condition.

- 1) Based on rotating inner ring.
- 2) The recommended INA precision locknuts are not included in the scope of delivery and must be ordered separately.
- 3) The required axial locknut force must be observed when using other locknuts.
- 4) Only valid in conjunction with INA precision locknuts.
Note the guidelines on locating/locating bearing arrangements, see page 54.
- 5) Heavy series.

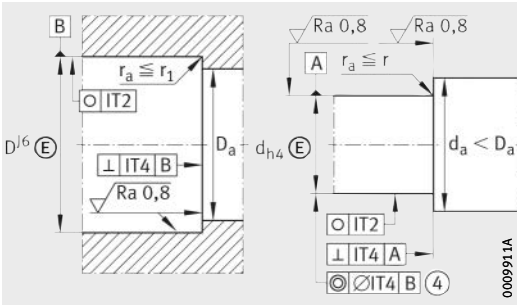

Design of housing and shaft (threaded spindle)

Limiting speed n_G grease min^{-1}	Thermally safe operating speed n_{th} min^{-1}	Bearing frictional torque M_R Nm	Rigidity axial c_{aL} N/ μm	Tilting rigidity c_{kL} Nm/mrad	Mass moment of inertia ¹⁾ M_m kg · cm ²	Axial runout ¹⁾ μm	Recommended INA precision locknut ²⁾			Required locknut force ³⁾ axial N
							For radial locking	For axial locking	Tightening torque ⁴⁾ M_A Nm	
4 000	1 800	0,7	1 000	550	2,26	2,5	ZM40	AM40	55	13 412
5 200	3 300	0,35	1 000	550	2,26	2,5	ZM40	AM40	55	13 412
3 500	1 600	1,3	1 200	750	5,5	2,5	ZMA40/62	AM40	110	25 185
4 400	3 100	0,65	1 200	750	5,5	2,5	ZMA40/62	AM40	110	25 185
3 200	1 500	0,9	1 250	1 000	5,24	2,5	ZM50	AM50	85	16 280
4 200	3 000	0,45	1 250	1 000	5,24	2,5	ZM50	AM50	85	16 280
2 900	1 200	2,6	1 400	1 500	15,2	2,5	ZMA50/75	AM50	150	28 451
3 500	2 500	1,3	1 400	1 500	15,2	2,5	ZMA50/75	AM50	150	28 451
4 000	3 000	1	1 300	1 650	13,7	3	ZMA60/98	AM60	100	16 700
3 800	2 800	1,2	1 450	2 250	19,8	3	ZMA70/110	AM70	130	19 031
3 600	2 700	1,4	1 600	3 000	27,6	3	ZMA80/120	AM80	160	20 604
3 500	2 300	2,3	1 700	4 400	59,9	3	ZMA90/130	AM90	200	22 731
3 300	2 150	2,6	1 900	5 800	85,3	3	ZMA100/140	AM100	250	25 624



Axial angular contact ball bearings

Without fixing holes
Less stringent tolerances

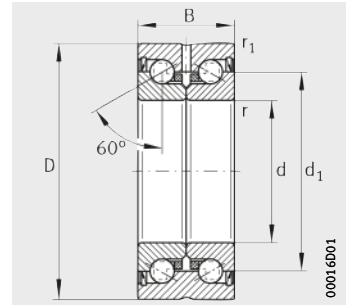

ZKLN...-2RS-PE

Dimension table - Dimensions in mm

Designation	Mass m ≈ kg	Dimensions						Mounting dimensions		Basic load ratings axial		Fatigue limit load C _u N
		d	D	B	d ₁	r	r ₁	D _a max.	d _a min.	dyn. C _a N	stat. C _{0a} N	
ZKLN0624-2RS-PE	0,03	6 ^{+0,003} _{-0,005}	24 _{-0,01}	15	14	0,3	0,6	19	9	6 900	8 500	375
ZKLN1034-2RS-PE	0,1	10 ^{+0,008} _{-0,008}	34 _{-0,011}	20	21	0,3	0,6	28	14	13 400	18 800	830
ZKLN1242-2RS-PE	0,2	12 ^{+0,01} _{-0,01}	42 _{-0,011}	25	25	0,3	0,6	33	16	16 900	24 700	1 090
ZKLN1545-2RS-PE	0,21	15 ^{+0,01} _{-0,01}	45 _{-0,011}	25	28	0,3	0,6	35	20	17 900	28 000	1 240
ZKLN1747-2RS-PE	0,22	17 ^{+0,01} _{-0,01}	47 _{-0,011}	25	30	0,3	0,6	37	23	18 800	31 000	1 380
ZKLN2052-2RS-PE	0,31	20 ^{+0,01} _{-0,01}	52 _{-0,013}	28	34,5	0,3	0,6	43	25	26 000	47 000	2 070
ZKLN2557-2RS-PE	0,34	25 ^{+0,01} _{-0,01}	57 _{-0,013}	28	40,5	0,3	0,6	48	32	27 500	55 000	2 450
ZKLN3062-2RS-PE	0,39	30 ^{+0,01} _{-0,01}	62 _{-0,013}	28	45,5	0,3	0,6	53	40	29 000	64 000	2 800
ZKLN3572-2RS-PE	0,51	35 ^{+0,01} _{-0,01}	72 _{-0,013}	34	52	0,3	0,6	62	45	41 000	89 000	3 950
ZKLN5090-2RS-PE	0,88	50 ^{+0,01} _{-0,01}	90 _{-0,015}	34	72	0,3	0,6	82	63	46 500	126 000	5 600

④ Only valid in assembled condition.

1) Based on rotating inner ring.

2) The recommended INA precision locknuts are not included in the scope of delivery and must be ordered separately.

3) The required axial locknut force must be observed when using other locknuts.

4) Only valid in conjunction with INA precision locknuts.

Note the guidelines on locating/locating bearing arrangements, see page 54.

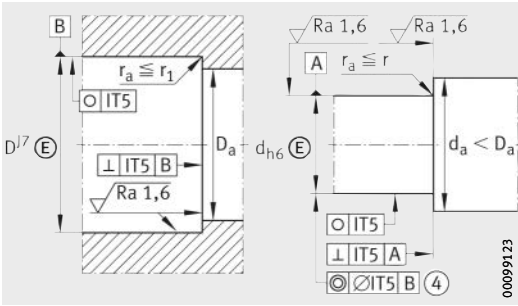

Design of housing and shaft (threaded spindle)

Limiting speed	Thermally safe operating speed	Bearing frictional torque	Rigidity axial	Tilting rigidity	Mass moment of inertia ¹⁾	Axial runout ¹⁾	Recommended INA precision locknut ²⁾			Required locknut force ³⁾ axial
							For radial locking	For axial locking	Tightening torque ⁴⁾	
n_G grease min^{-1}	n_ϑ min^{-1}	M_R Nm	c_{aL} $\text{N}/\mu\text{m}$	c_{kL} Nm/mrad	M_m $\text{kg} \cdot \text{cm}^2$	μm			M_A Nm	N
16 400	6 800	0,04	200	8	0,0044	5	ZM06	–	2	2 404
10 900	4 600	0,12	325	25	0,029	5	ZM10	–	6	4 891
9 200	3 800	0,16	375	50	0,068	5	ZM12	–	8	5 307
8 200	3 500	0,2	400	65	0,102	5	ZM15	AM15	10	5 484
7 600	3 300	0,24	450	80	0,132	5	ZM17	AM17	15	7 514
6 600	3 000	0,3	650	140	0,273	5	ZM20	AM20	18	8 258
5 700	2 600	0,4	750	200	0,486	5	ZM25	AM25	25	9 123
5 000	2 200	0,5	850	300	0,73	5	ZM30	AM30	32	9 947
4 400	2 000	0,6	900	400	1,51	5	ZM35	AM35/38	40	10 770
3 200	1 500	0,9	1 250	1 000	5,24	5	ZM50	AM50	85	16 280



Axial angular contact ball bearings

Without fixing holes
Matched pair

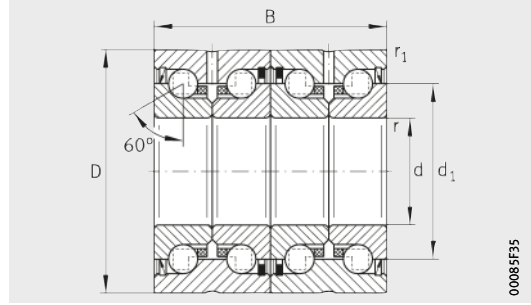

ZKLN..-2RS-2AP

Dimension table - Dimensions in mm

Designation	X-life	Mass m ≈ kg	Dimensions						Mounting dimensions		Basic load ratings axial		Fatigue limit load C _u N
			d	D	B	d ₁	r	r ₁	D _a max.	d _a min.	dyn. C _a N	stat. C _{0a} N	
ZKLN1747-2RS-2AP	XL	0,44	17	47	50	30	0,3	0,6	37	23	33 500	62 000	3 700
ZKLN2052-2RS-2AP	XL	0,62	20	52	56	34,5	0,3	0,6	43	25	46 000	94 000	5 500
ZKLN2557-2RS-2AP	XL	0,68	25	57	56	40,5	0,3	0,6	48	32	49 000	111 000	6 500
ZKLN3062-2RS-2AP	XL	0,78	30	62	56	45,5	0,3	0,6	53	40	52 000	127 000	7 500
ZKLN3572-2RS-2AP	XL	1,02	35	72	68	52	0,3	0,6	62	45	73 000	177 000	10 500
ZKLN4075-2RS-2AP	XL	1,22	40	75	68	58	0,3	0,6	67	50	77 000	202 000	11 900
ZKLN5090-2RS-2AP	XL	1,76	50	90	68	72	0,3	0,6	82	63	83 000	250 000	14 900

Further sizes and designs with seals 2Z available by agreement.

④ Only valid in assembled condition.

- 1) Based on rotating inner ring.
- 2) The recommended INA precision locknuts are not included in the scope of delivery and must be ordered separately.
- 3) The required axial locknut force must be observed when using other locknuts.
- 4) Only valid in conjunction with INA precision locknuts.
Note the guidelines on locating/locating bearing arrangements, see page 54.

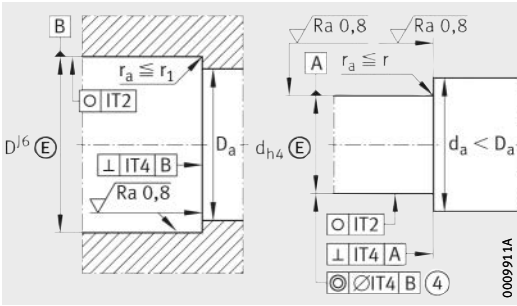

Design of housing and shaft (threaded spindle)

Limiting speed	Thermally safe operating speed	Bearing frictional torque	Rigidity axial	Tilting rigidity	Mass moment of inertia ¹⁾	Axial runout ¹⁾	Recommended INA precision locknut ²⁾			Required locknut force ³⁾ axial
							For radial locking	For axial locking	Tightening torque ⁴⁾	
n_G grease min^{-1}	n_ϑ min^{-1}	M_R Nm	c_{aL} $\text{N}/\mu\text{m}$	c_{kL} Nm/mrad	M_m $\text{kg} \cdot \text{cm}^2$	μm			M_A Nm	N
7 600	3 300	0,36	800	200	0,264	2	ZM17	AM17	15	7 514
6 600	3 000	0,45	1 150	320	0,546	2	ZMA20/38	AM20	18	8 258
5 700	2 600	0,6	1 300	450	0,972	2	ZMA25/45	AM25	25	9 123
5 000	2 200	0,75	1 500	620	1,46	2,5	ZMA30/52	AM30	32	9 947
4 400	2 000	0,9	1 600	900	3,02	2,5	ZMA35/58	AM35/58	40	10 770
4 000	1 800	1,05	1 750	1 200	4,52	2,5	ZMA40/62	AM40	55	13 412
3 200	1 500	1,35	2 200	2 250	10,48	2,5	ZMA50/75	AM50	85	16 280



Axial angular contact ball bearings

Single direction
Open

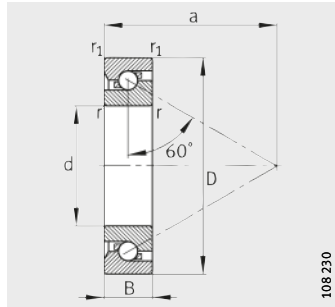

7602, 7603, BSB

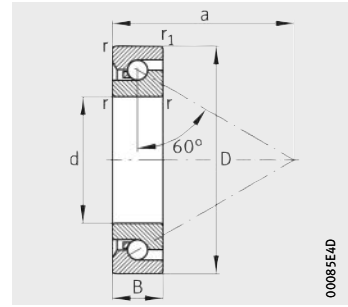

BSB..SU

Dimension table - Dimensions in mm

Designation	Mass m ≈ kg	Dimensions						Mounting dimensions		Basic load ratings axial		Fatigue limit load C _u N
		d	D	B	r	r ₁	a	D _a H12	d _a h12	dyn. C _a N	stat. C _{0a} N	
7602012-TVP	0,042	12_{-0,004}	32 _{-0,006}	10 _{-0,08}	0,6	0,6	24	27	17	12 200	20 700	920
7602015-TVP	0,052	15_{-0,004}	35 _{-0,006}	11 _{-0,08}	0,6	0,6	27,5	30	20,5	13 100	24 700	1090
7602017-TVP	0,074	17_{-0,004}	40 _{-0,006}	12 _{-0,08}	0,6	0,6	31	34,5	23	17 200	32 500	1430
BSB1747-SU	0,13	17_{-0,004}	47 _{-0,006}	15 _{-0,12}	1	0,6	29,9	43	27	26 000	47 000	2070
BSB1747-SU-L055	0,13	17_{-0,004}	47 _{-0,006}	15 _{-0,12}	1	0,6	29,9	43	27	26 000	47 000	2070
7602020-TVP	0,139	20_{-0,005}	47 _{-0,006}	14 _{-0,12}	1	1	36	39,5	27,5	19 100	38 000	1670
BSB2047-SU	0,12	20_{-0,005}	47 _{-0,006}	15 _{-0,12}	1	0,6	29,9	43	27	26 000	47 000	2070
BSB2047-SU-L055	0,12	20_{-0,005}	47 _{-0,006}	15 _{-0,12}	1	0,6	29,9	43	27	26 000	47 000	2070
7603020-TVP	0,17	20_{-0,005}	52 _{-0,007}	15 _{-0,12}	1,1	1,1	39,5	43,5	30,5	25 500	53 000	2360
7602025-TVP	0,147	25_{-0,005}	52 _{-0,007}	15 _{-0,12}	1	1	41	45	32	23 200	50 000	2220
BSB2562-SU	0,24	25_{-0,005}	62 _{-0,007}	15 _{-0,12}	1	0,6	39,4	54	38	29 000	64 000	2800
BSB2562-SU-L055	0,24	25_{-0,005}	62 _{-0,007}	15 _{-0,12}	1	0,6	39,4	54	38	29 000	64 000	2800
7603025-TVP	0,275	25_{-0,005}	62 _{-0,007}	17 _{-0,12}	1,1	1,1	47,5	52	38	29 500	68 000	3000
BSB3062-SU	0,22	30_{-0,005}	62 _{-0,007}	15 _{-0,12}	1	0,6	39,4	54	38	29 000	64 000	2800
BSB3062-SU-L055	0,22	30_{-0,005}	62 _{-0,007}	15 _{-0,12}	1	0,6	39,4	54	38	29 000	64 000	2800
7602030-TVP	0,232	30_{-0,005}	62 _{-0,007}	16 _{-0,12}	1	1	48	52,5	39,5	27 500	66 000	2900
7603030-TVP	0,409	30_{-0,005}	72 _{-0,007}	19 _{-0,12}	1,1	1,1	55,5	61	45	36 500	89 000	3950

④ Only valid in assembled condition.

- 1) Valid for single bearings with stated preload.
- 2) Valid for matched pair of bearings in O or X arrangement.
- 3) Based on rotating inner ring.
- 4) The recommended INA precision locknuts are not included in the scope of delivery and must be ordered separately.
- 5) The required axial locknut force must be observed when using other locknuts.
- 6) Only valid in conjunction with INA precision locknuts.
Note the guidelines on locating/locating bearing arrangements, see page 54.

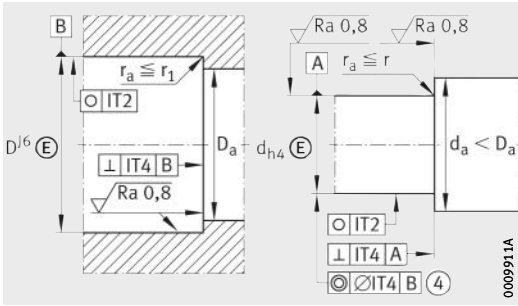

Design of housing and shaft (threaded spindle)

Limiting speed n_G grease min^{-1}	Thermally safe operating speed n_{ϑ} min^{-1}	Bearing frictional torque ¹⁾		Rigidity ²⁾ axial c_{aL} $\text{N}/\mu\text{m}$	Axial runout ³⁾ μm	Recommended INA precision locknut ⁴⁾			Required locknut force ⁵⁾ axial N
		lightly oiled M_R Nm	greased M_R Nm			For radial locking	For axial locking	Tightening torque ⁶⁾ M_A Nm	
14 100	8 000	0,015	–	476	2	ZM12	–	8	6 110
12 300	6 700	0,02	–	516	2	ZM15	AM15	10	5 740
10 600	6 000	0,03	–	596	2	ZM17	AM17	15	8 060
8 700	6 200	–	0,2	764	2	ZM17	AM17	15	9 000
8 700	6 200	–	0,2	764	2	ZM17	AM17	15	9 000
9 200	5 000	0,05	–	703	2	ZM20	AM20	18	8 490
8 700	6 200	–	0,2	764	2	ZM20	AM20	18	9 000
8 700	6 200	–	0,2	764	2	ZM20	AM20	18	9 000
8 200	4 500	0,06	–	787	2	ZM20	AM20	25	11 600
8 000	4 500	0,065	–	772	2	ZM25	AM25	25	9 430
6 700	5 400	–	0,25	1 001	2	ZMA25/45	AM25	30	11 810
6 700	5 400	–	0,25	1 001	2	ZMA25/45	AM25	30	11 810
6 800	3 800	0,085	–	917	2	ZM25	AM25	40	14 480
6 700	5 400	–	0,25	1 034	2,5	ZM30	AM30	32	11 080
6 700	5 400	–	0,25	1 034	2,5	ZM30	AM30	32	11 080
6 700	3 800	0,085	–	893	2	ZM30	AM30	32	10 240
5 700	3 200	0,13	–	1 073	2	ZM30	AM30	55	16 180



Axial angular contact ball bearings

Single direction
Open

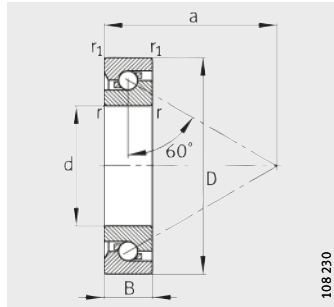

7602, 7603, BSB

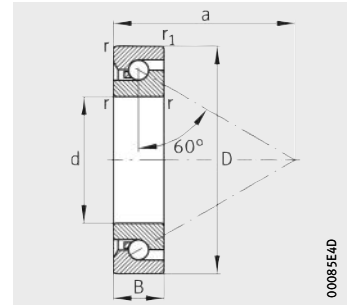

BSB.-SU

Dimension table (continued) · Dimensions in mm

Designation	Mass m ≈ kg	Dimensions						Mounting dimensions		Basic load ratings axial		Fatigue limit load C _u N
		d	D	B	r	r ₁	a	D _a H12	d _a h12	dyn. C _a N	stat. C _{0a} N	
BSB3572-SU	0,3	35_{-0,006}	72 _{-0,007}	15 _{-0,12}	1	0,6	48,5	65	47	37 000	89 000	3 950
BSB3572-SU-L055	0,3	35_{-0,006}	72 _{-0,007}	15 _{-0,12}	1	0,6	48,5	65	47	37 000	89 000	3 950
7602035-TVP	0,339	35_{-0,006}	72 _{-0,007}	17 _{-0,12}	1,1	1,1	55	60,5	46,5	31 500	81 000	3 600
7603035-TVP	0,546	35_{-0,006}	80 _{-0,007}	21 _{-0,12}	1,5	1,5	61,5	67	51	38 000	100 000	4 450
BSB4072-SU	0,26	40_{-0,006}	72 _{-0,007}	15 _{-0,12}	1	0,6	48,5	65	47	37 000	89 000	3 950
BSB4072-SU-L055	0,26	40_{-0,006}	72 _{-0,007}	15 _{-0,12}	1	0,6	48,5	65	47	37 000	89 000	3 950
7602040-TVP	0,418	40_{-0,006}	80 _{-0,007}	18 _{-0,12}	1,1	1,1	62,5	69,5	53,5	39 000	106 000	4 650
BSB040090-T	0,65	40_{-0,006}	90 _{-0,008}	20 _{-0,12}	1,5	1,5	67	75,5	56,5	52 000	138 000	6 100
7603040-TVP	0,751	40_{-0,006}	90 _{-0,008}	23 _{-0,12}	1,5	1,5	68,5	75,5	56,5	52 000	138 000	6 100
BSB045075-T	0,26	45_{-0,006}	75 _{-0,007}	15 _{-0,12}	1	1	59,5	68	52	30 000	85 000	3 750
7602045-TVP	0,488	45_{-0,006}	85 _{-0,008}	19 _{-0,12}	1,1	1,1	66	73	57	39 500	111 000	4 900
BSB045100-T	0,81	45_{-0,006}	100 _{-0,008}	20 _{-0,12}	1,5	1,5	75	85,5	64,5	62 000	172 000	7 600
7603045-TVP	0,992	45_{-0,006}	100 _{-0,008}	25 _{-0,12}	1,5	1,5	77,5	85,5	64,5	62 000	172 000	7 600
7602050-TVP	0,557	50_{-0,006}	90 _{-0,008}	20 _{-0,12}	1,1	1,1	71,5	79	63	41 000	122 000	5 400
BSB050100-T	0,75	50_{-0,006}	100 _{-0,008}	20 _{-0,12}	1,5	1,5	75	85,5	64,5	62 000	172 000	7 600
7603050-TVP	1,29	50_{-0,006}	110 _{-0,008}	27 _{-0,12}	2	2	85,5	94	72	72 000	203 000	9 000
BSB055090-T	0,38	55_{-0,007}	90 _{-0,008}	15 _{-0,15}	1,0	1,0	70,5	80	65	33 500	98 000	4 300
7602055-TVP	0,74	55_{-0,007}	100 _{-0,008}	21 _{-0,15}	1,5	1,5	77,5	85,5	69,5	42 000	132 000	5 800
BSB055120-T⁷⁾	1,2	55_{-0,007}	120 _{-0,008}	20 _{-0,15}	2,0	2,0	86	97,5	77	63 000	188 000	8 300
7603055-TVP⁷⁾	1,67	55_{-0,007}	120 _{-0,008}	29 _{-0,15}	2	2	91,5	101	77	85 000	255 000	11 200
BSB060120-T	1,1	60_{-0,007}	120 _{-0,008}	20 _{-0,15}	1,5	1,5	88	100,5	79,5	64 000	196 000	8 700

④ Only valid in assembled condition.

1) Valid for single bearings with stated preload.

2) Valid for matched pair of bearings in O or X arrangement.

3) Based on rotating inner ring.

4) The recommended INA precision locknuts are not included in the scope of delivery and must be ordered separately.

5) The required axial locknut force must be observed when using other locknuts.

6) Only valid in conjunction with INA precision locknuts.

Note the guidelines on locating/locating bearing arrangements, see page 54.

7) Delivery possibility by agreement.

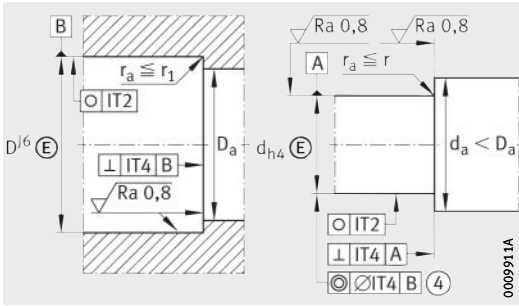

Design of housing and shaft (threaded spindle)

Limiting speed n_G grease min^{-1}	Thermally safe operating speed n_{ϑ} min^{-1}	Bearing frictional torque ¹⁾		Rigidity ²⁾ axial c_{aL} $\text{N}/\mu\text{m}$	Axial runout ³⁾ μm	Recommended INA precision locknut ⁴⁾			Required locknut force ⁵⁾ axial N
		lightly oiled M_R Nm	greased M_R Nm			For radial locking	For axial locking	Tightening torque ⁶⁾ M_A Nm	
5 400	4 700	–	0,35	1 196	2,5	ZM35	AM35	50	15 220
5 400	4 700	–	0,35	1 196	2,5	ZM35	AM35	50	15 220
5 700	3 200	0,115	–	1 020	2	ZM35	AM35	40	11 310
5 100	3 000	0,17	–	1 192	2	ZM35	AM35	65	17 380
5 400	4 700	–	0,35	1 235	2,5	ZM40	AM40	60	15 650
5 400	4 700	–	0,35	1 235	2,5	ZM40	AM40	60	15 650
4 900	2 800	0,17	–	1 190	2	ZM40	AM40	55	13 330
4 500	3 100	0,225	–	1 292	2	ZM40	AM40	110	25 120
4 500	2 600	0,225	–	1 292	2	ZM40	AM40	110	25 120
5 100	3 300	0,13	–	1 072	2	ZM45	AM45	50	11 140
4 700	2 600	0,19	–	1 247	2	ZM45	AM45	65	14 410
4 000	2 700	0,3	–	1 473	2	ZM45	AM45	120	25 160
4 000	2 200	0,3	–	1 473	2	ZM45	AM45	120	25 160
4 300	2 400	0,23	–	1 360	2	ZM50	AM50	85	16 810
4 000	2 700	0,33	–	1 473	2	ZM50	AM50	120	23 770
3 600	2 000	0,36	–	1 601	2	ZM50	AM50	150	28 930
4 200	2 800	0,19	–	1 246	3	ZM55	AM55	60	12 040
3 900	2 200	0,25	–	1 394	3	ZM55	AM55	85	15 060
3 400	2 400	0,36	–	1 553	3	ZM55	AM55	110	20 070
3 300	1 900	0,46	–	1 723	3	ZM55	AM55	130	24 120
3 800	2 300	0,38	–	1 623	3	ZM60	AM60	120	20 020



Axial angular contact ball bearings

Single direction
Sealed on both sides

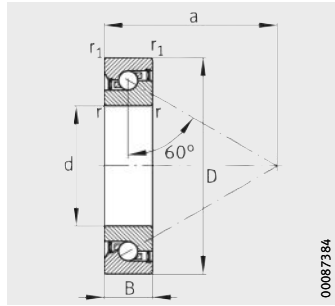

7602...-2RS, 7603...-2RS,
BSB...-2RS

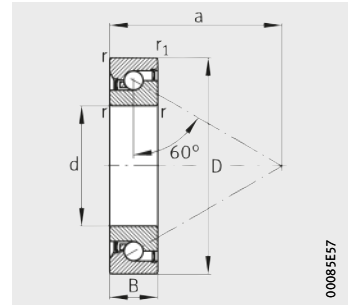

BSB...-2Z-SU

Dimension table - Dimensions in mm

Designation	Mass m ≈ kg	Dimensions						Mounting dimensions		Basic load ratings axial	
		d	D	B	r, min.	r ₁ min.	a ≈	D _a H12	d _a h12	dyn. C _a N	stat. C _{0a} N
7602012-2RS-TVP	0,042	12 _{-0,004}	32 _{-0,006}	10 _{-0,08}	0,6	0,6	24	27	17	12 200	20 700
7602015-2RS-TVP	0,052	15 _{-0,004}	35 _{-0,006}	11 _{-0,08}	0,6	0,6	27,5	30	20,5	13 100	24 700
BSB1747-2Z-SU	0,13	17 _{-0,004}	47 _{-0,006}	15 _{-0,12}	1	0,6	29,9	43	27	26 000	47 000
7602020-2RS-TVP	0,12	20 _{-0,005}	47 _{-0,006}	14 _{-0,12}	1	1	36	39,5	27,5	19 100	38 000
BSB2047-2Z-SU	0,12	20 _{-0,005}	47 _{-0,006}	15 _{-0,12}	1	0,6	29,9	43	27	26 000	47 000
7603020-2RS-TVP	0,17	20 _{-0,005}	52 _{-0,007}	15 _{-0,12}	1,1	1,1	36,5	43,5	30,5	25 500	53 000
7602025-2RS-TVP	0,15	25 _{-0,005}	52 _{-0,007}	15 _{-0,12}	1	1	41	45	32	23 200	50 000
BSB2562-2Z-SU	0,24	25 _{-0,005}	62 _{-0,007}	15 _{-0,12}	1	0,6	39,4	54	38	29 000	64 000
7603025-2RS-TVP	0,27	25 _{-0,005}	62 _{-0,007}	17 _{-0,12}	1,1	1,1	47,5	52	38	29 500	68 000
BSB3062-2Z-SU	0,22	30 _{-0,005}	62 _{-0,007}	15 _{-0,12}	1	0,6	39,4	54	38	29 000	64 000
7602030-2RS-TVP	0,23	30 _{-0,005}	62 _{-0,007}	16 _{-0,12}	1	1	48	52,5	39,5	27 500	66 000
BSB3572-2Z-SU	0,3	35 _{-0,006}	72 _{-0,007}	15 _{-0,12}	1	0,6	48,5	65	47	37 000	89 000
BSB4072-2Z-SU	0,26	40 _{-0,006}	72 _{-0,007}	15 _{-0,12}	1	0,6	48,5	65	47	37 000	89 000

④ Only valid in assembled condition.

- 1) Valid for single bearings with stated preload.
- 2) Valid for matched pair of bearings in O or X arrangement.
- 3) Based on rotating inner ring.
- 4) The recommended INA precision locknuts are not included in the scope of delivery and must be ordered separately.
- 5) The required axial locknut force must be observed when using other locknuts.
- 6) Only valid in conjunction with INA precision locknuts.
Note the guidelines on locating/locating bearing arrangements, see page 54.

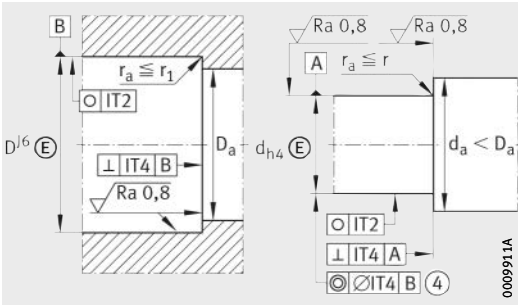

Design of housing and shaft (threaded spindle)

Fatigue limit load C_u N	Limiting speed n_G grease min^{-1}	Thermally safe operating speed n_{ϑ} min^{-1}	Bearing frictional torque ¹⁾ M_R Nm	Rigidity ²⁾ axial c_{aL} N/ μm	Axial runout ³⁾ μm	Recommended INA precision locknut ⁴⁾			Required locknut force ⁵⁾ axial N
						For radial locking	For axial locking	Tightening torque ⁶⁾ M_A Nm	
920	10 400	8 000	0,018	476	2	ZM12	AM12	8	6 110
1 090	9 000	6 700	0,024	516	2	ZM15	AM15	10	5 740
2 750	8 700	6 200	0,2	764	2	ZM20	AM20	18	9 000
1 670	6 800	5 000	0,06	703	2	ZM20	AM20	18	8 490
2 070	8 700	6 200	0,2	764	2	ZM20	AM20	18	9 000
2 360	6 200	4 500	0,07	787	2	ZM20	AM20	18	11 600
2 220	5 100	3 800	0,08	772	2	ZM25	AM25	25	9 430
2 800	6 700	5 400	0,25	1 001	2	ZMA25/45	AM25	30	11 810
3 000	5 100	3 800	0,1	917	2	ZM25	AM25	40	14 480
2 800	6 700	5 400	0,25	1 034	2,5	ZM30	AM30	32	11 080
2 900	5 000	3 800	0,1	893	2	ZM30	AM30	32	10 240
3 950	5 400	4 700	0,35	1 196	2,5	ZM35	AM35	50	15 220
3 950	5 400	4 700	0,35	1 235	2,5	ZM40	AM40	60	15 650



Angular contact ball bearing units

With fixing holes

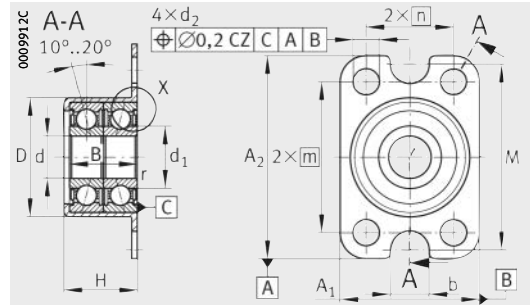

ZKLR0624-2Z, ZKLR0828-2Z

Dimension table - Dimensions in mm

Designation	Mass m ≈ kg	Dimensions							
		d	A ₁	A ₂	D +0,03 -0,01	B ±0,25	d ₁	r min.	d ₂
ZKLR0624-2Z	0,023	6 _{-0,008}	24	35	20,5	12	9	0,3	4,5
ZKLR0828-2Z	0,03	8 _{-0,008}	28	35	23,9	14	11	0,3	4,5
ZKLR1035-2Z	0,05	10 _{-0,008}	35	35	28,14	16	13,55	0,3	4,5
ZKLR1244-2RS	0,12	12 _{-0,007}	44	50	35,45	20	16,6	0,3	6,6
ZKLR1547-2RS	0,14	15 _{-0,007}	47	51	38,45	22	18	0,3	6,6
ZKLR2060-2RS	0,3	20 _{-0,008}	60	60	50,45	28	24,4	0,3	6,6

Performance data

Designation	Basic load ratings				Fatigue limit load C _u N	Limiting speed n _G grease min ⁻¹
	radial		axial			
	dyn. C _r N	stat. C _{0r} N	dyn. C _a N	stat. C _{0a} N		
ZKLR0624-2Z	4 100	2 060	1 650	1 520	104	7 300
ZKLR0828-2Z	5 000	2 700	2 060	1 850	138	6 200
ZKLR1035-2Z	7 000	3 900	2 430	2 420	197	5 100
ZKLR1244-2RS	13 600	8 500	13 200	17 900	430	3 700
ZKLR1547-2RS	16 700	10 700	16 400	22 400	540	3 400
ZKLR2060-2RS	28 000	19 100	27 500	40 000	970	2 800

② Adjacent construction, bearing screw mounted on flat surface. ④ Only valid in assembled condition.

- 1) The screws are not included in the scope of delivery. Tightening torque according to manufacturer's data.
- 2) Statistically determined mean values from measurements on the complete bearing. Due to the specific design, larger fluctuations in rigidity should be expected with axial angular contact ball bearing units ZKLR.
- 3) Based on rotating inner ring.
- 4) The locknut is only used to axially locate the bearing unit. It has no influence on the bearing preload.
- 5) The recommended INA precision locknuts are not included in the scope of delivery and must be ordered separately.
- 6) Only valid in conjunction with INA precision locknuts.
- 7) The geometrical tolerances stated are only required in the area of the diameter between D_{ai} and D_{aa}. When indicating IT5-7, the tolerance to be selected of IT5 to IT7 is dependent on the accuracy requirement of the subassembly.

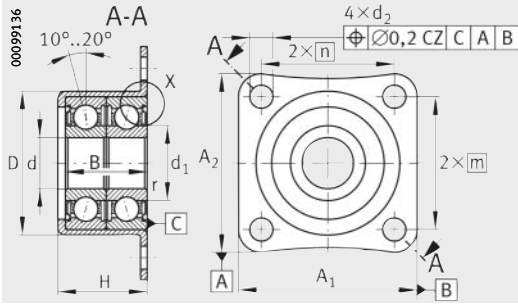

ZKLR1035-2Z

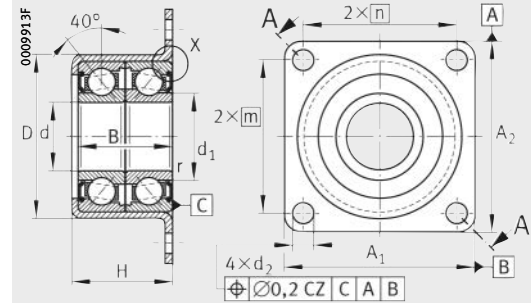

ZKLR1244-2RS, ZKLR1547-2RS, ZKLR2060-2RS

b	m	n	M	H	d _a	D _{ai}	D _{aa}	Fixing screws ¹⁾ DIN EN ISO 4762		
				-0,5			min.	Size	n	t ₁
6,6	26	15	32	13	8	16	19	M4 M6	4 2	0,2
6,6	26	20	35	15,5	10,4	18	22	M4 M6	4 2	0,2
-	26	26	-	17,5	12,4	22	26	M4	4	0,2
-	38	32	-	22	14	27	32	M6	4	0,2
-	39	35	-	24	17,5	29	35	M6	4	0,2
-	47	47	-	30	24	39	47	M6	4	0,2

Bearing frictional torque M _R	Rigidity ²⁾ axial c _{aL}	Mass moment of inertia ³⁾ M _m	Axial runout ³⁾ μm	Recommended INA precision locknut ⁴⁾⁵⁾		
				For radial locking	For axial locking	Tightening torque ⁶⁾ M _A
Nm	N/μm	kg · cm ²				Nm
0,04	14	0,0014	7	ZM06	-	2
0,08	16	0,0028	7	ZM08	-	4
0,12	19	0,0075	7	ZM10	-	6
0,16	170	0,0102	7	ZM12	-	8
0,2	200	0,0178	7	ZM15	AM15	10
0,3	250	0,263	8	ZM20	AM20	18

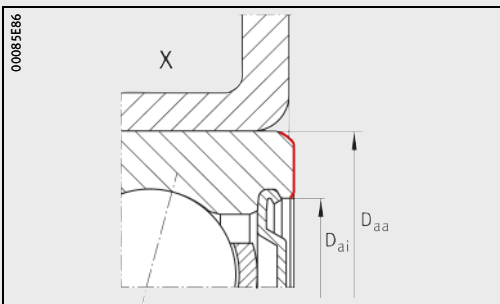

Axial abutment area of outer ring

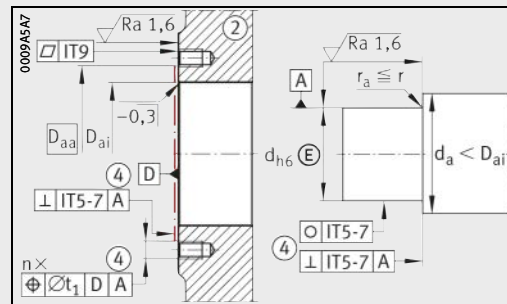

Design of housing and shaft⁷⁾

Double row axial angular contact ball bearings with flange

With fixing holes

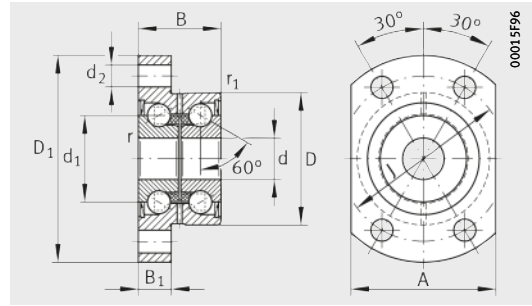

ZKLFA...-2RS, ZKLFA...-2Z

Dimension table - Dimensions in mm

Designation	Mass m ≈ kg	Dimensions					
		d	D -0,01	B -0,25	d ₁	D ₁	r min.
ZKLFA0630-2Z ²⁾	0,05	6 ^{+0,002} _{-0,003}	19	12	12	30	0,3
ZKLFA0640-2RS	0,08	6 ^{+0,002} _{-0,003}	24	15	14	40	0,3
ZKLFA0640-2Z	0,08	6 ^{+0,002} _{-0,003}	24	15	14	40	0,3
ZKLFA0850-2RS	0,17	8 ⁰ _{-0,005}	32	20	19	50	0,3
ZKLFA0850-2Z	0,17	8 ⁰ _{-0,005}	32	20	19	50	0,3

Performance data

Designation	Basic load ratings		Fatigue limit load C _u N	Limiting speed n _{G grease} min ⁻¹	Thermally safe operating speed n _θ min ⁻¹	Bearing frictional torque M _R Nm
	axial					
	dyn. C _a N	stat. C _{0a} N				
ZKLFA0630-2Z ²⁾	4 900	6 100	270	22 800	14 000	0,01
ZKLFA0640-2RS	6 900	8 500	375	16 400	6 800	0,04
ZKLFA0640-2Z	6 900	8 500	375	19 900	12 000	0,02
ZKLFA0850-2RS	12 500	16 300	720	12 100	5 100	0,08
ZKLFA0850-2Z	12 500	16 300	720	15 500	9 500	0,04

② Adjacent construction, bearing screw mounted on flat surface. ④ Only valid in assembled condition.

¹⁾ The screws are not included in the scope of delivery. Tightening torque according to manufacturer's data.

²⁾ No relubrication facility.

³⁾ Based on rotating inner ring.

⁴⁾ The recommended INA precision locknuts are not included in the scope of delivery and must be ordered separately.

⁵⁾ The required axial locknut force must be observed when using other locknuts.

⁶⁾ Only valid in conjunction with INA precision locknuts.

Note the guidelines on locating/locating bearing arrangements, see page 54.

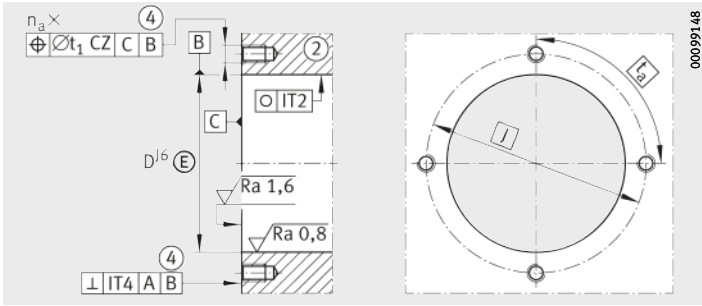

Housing design

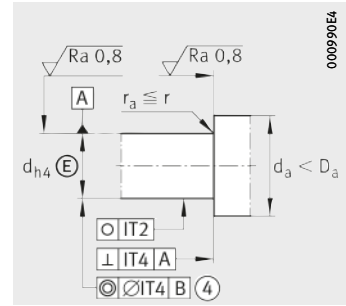

Shaft design
(threaded spindle)



					Mounting dimensions			Fixing screws ¹⁾ DIN EN ISO 4762 10.9	
r ₁ min.	B ₁	d ₂	J	A	d _a		t ₁	Size	n _a × t _a
					min.	max.			
0,3	5	3,5	24	22	9	15	0,1	M3	4 × 90°
0,6	6	4,5	32	27	9	18	0,1	M4	4 × 90°
0,6	6	4,5	32	27	9	18	0,1	M4	4 × 90°
0,6	8	5,5	40	35	11	25	0,1	M5	4 × 90°
0,6	8	5,5	40	35	11	25	0,1	M5	4 × 90°

Rigidity axial c _{aL} N/μm	Tilting rigidity c _{kL} Nm/ mrad	Mass moment of inertia ³⁾ M _m kg · cm ²	Axial runout ³⁾ μm	Recommended INA precision locknut ⁴⁾			Required locknut force ⁵⁾ axial N
				For radial locking	For axial locking	Tightening torque ⁶⁾ M _A Nm	
150	4	0,0019	2	ZM06	–	2	2 010
200	8	0,0044	2	ZM06	–	2	2 404
200	8	0,0044	2	ZM06	–	2	2 404
250	20	0,02	2	ZM08	–	4	3 468
250	20	0,02	2	ZM08	–	4	3 468

Double row axial angular contact ball bearings with flange

With fixing holes

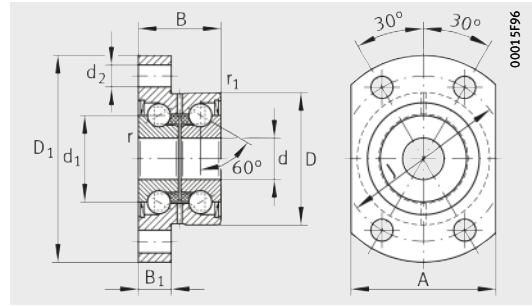

ZKLFA...-2RS, ZKLFA...-2Z

Dimension table (continued) · Dimensions in mm

Designation	Mass m ≈ kg	Dimensions					
		d -0,005	D -0,01	B -0,25	d ₁	D ₁	r min.
ZKLFA1050-2RS	0,18	10	32	20	21	50	0,3
ZKLFA1050-2Z	0,18	10	32	20	21	50	0,3
ZKLFA1263-2RS	0,3	12	42	25	25	63	0,3
ZKLFA1263-2Z	0,3	12	42	25	25	63	0,3
ZKLFA1563-2RS	0,31	15	42	25	28	63	0,3
ZKLFA1563-2Z	0,31	15	42	25	28	63	0,3

Performance data

Designation	Basic load ratings		Fatigue limit load C _u N	Limiting speed n _{G grease} min ⁻¹	Thermally safe operating speed n _θ min ⁻¹	Bearing frictional torque M _R Nm
	axial					
	dyn. C _a N	stat. C _{0a} N				
ZKLFA1050-2RS	13 400	18 800	830	10 900	4 600	0,12
ZKLFA1050-2Z	13 400	18 800	830	14 400	8 600	0,06
ZKLFA1263-2RS	16 900	24 700	1 090	9 200	3 800	0,16
ZKLFA1263-2Z	16 900	24 700	1 090	12 000	7 600	0,08
ZKLFA1563-2RS	17 900	28 000	1 240	8 200	3 500	0,2
ZKLFA1563-2Z	17 900	28 000	1 240	10 800	7 000	0,1

② Adjacent construction, bearing screw mounted on flat surface. ④ Only valid in assembled condition.

1) The screws are not included in the scope of delivery.
Tightening torque according to manufacturer's data.

2) Based on rotating inner ring.

3) The recommended INA precision locknuts are not included in the scope of delivery and must be ordered separately.

4) The required axial locknut force must be observed when using other locknuts.

5) Only valid in conjunction with INA precision locknuts.

Note the guidelines on locating/locating bearing arrangements, see page 54.

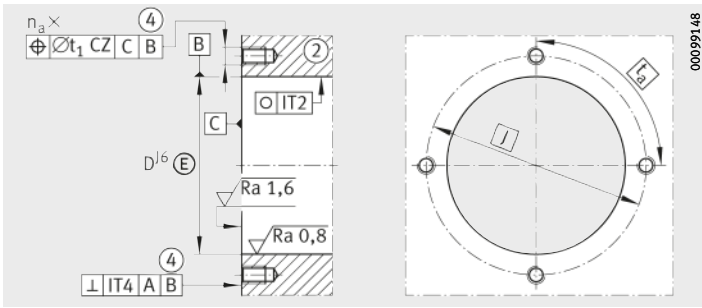

Housing design

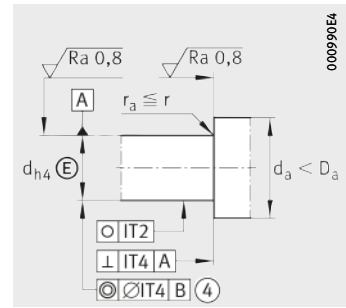

Shaft design
(threaded spindle)



					Mounting dimensions			Fixing screws ¹⁾ DIN EN ISO 4762 10.9	
r ₁ min.	B ₁	d ₂	J	A	d _a		t ₁	Size	n _a × t _a
					min.	max.			
0,6	8	5,5	40	35	14	27	0,1	M5	4 × 90°
0,6	8	5,5	40	35	14	27	0,1	M5	4 × 90°
0,6	10	6,8	53	45	16	31	0,1	M6	4 × 90°
0,6	10	6,8	53	45	16	31	0,1	M6	4 × 90°
0,6	10	6,8	53	45	20	34	0,1	M6	4 × 90°
0,6	10	6,8	53	45	20	34	0,1	M6	4 × 90°

Rigidity axial c _{aL}	Tilting rigidity c _{kL}	Mass moment of inertia ²⁾ M _m	Axial runout ²⁾ μm	Recommended INA precision locknut ³⁾			Required locknut force ⁴⁾ axial N
				For radial locking	For axial locking	Tightening torque ⁵⁾ M _A	
N/μm	Nm/ mrad	kg · cm ²				Nm	N
325	25	0,029	2	ZM10	–	6	4 891
325	25	0,029	2	ZM10	–	6	4 891
375	50	0,068	2	ZM12	–	8	5 307
375	50	0,068	2	ZM12	–	8	5 307
400	65	0,102	2	ZM15	AM15	10	5 484
400	65	0,102	2	ZM15	AM15	10	5 484

Triple row axial angular contact ball bearings with flange

With fixing holes

Attention!

The bearings require continuous load in the main load direction \oplus .

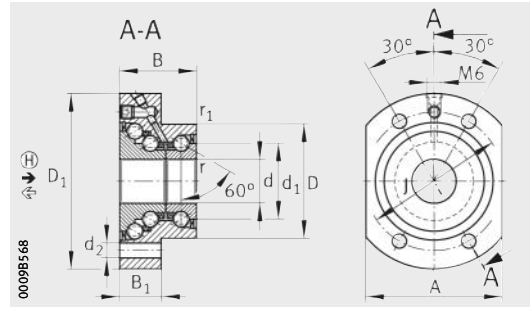

DKLFA...2RS ($d \leq 20 \text{ mm}$)

Dimension table - Dimensions in mm

Designation	Mass m ≈ kg	Dimensions											Mounting dimensions	
		d	D	B	d ₁	D ₁	r	r ₁	B ₁	d ₂	J	A	d _a	
		-0,010	-0,013	-0,25			min.	min.					min.	max.
DKLFA1575-2RS	0,53	15	45	32	28	75	0,3	0,6	18	6,8	58	55	20	35
DKLFA2080-2RS	0,7	20	52	35	34,5	80	0,3	0,6	19	6,8	63	62	25	43
DKLFA2590-2RS	0,9	25	57	38	40,5	90	0,3	0,6	22	8,8	75	70	32	48
DKLFA30100-2RS	1	30	62	38	45,5	100	0,3	0,6	22	8,8	80	72	40	53
DKLFA30110-2RS³⁾	2,5	30	75	56	51	110	0,3	0,6	35	8,8	95	85	47	64
DKLFA40115-2RS	1,5	40	72	42	58	115	0,3	0,6	23	8,8	94	90	50	67
DKLFA40140-2RS³⁾	4,2	40	90	60	65	140	0,3	0,6	35	11	118	110	56	80

④ Only valid in assembled condition. ⑤ Adjacent construction, bearing screw mounted on flat surface.

⑥ Bearing centred in adjacent construction.

- 1) The screws are not included in the scope of delivery. Tightening torque according to manufacturer's data.
- 2) Based on rotating inner ring.
- 3) Heavy series.
- 4) The recommended INA precision locknuts are not included in the scope of delivery and must be ordered separately.
- 5) The required axial locknut force must be observed when using other locknuts.
- 6) Only valid in conjunction with INA precision locknuts in locating/non-locating bearing arrangements and for ① in locating/locating bearing arrangements.
Note the guidelines on locating/locating bearing arrangements, see page 54.

Triple row angular contact ball bearing	Tilting rigidity c_{kL} Nm/mrad	Axial runout μm	Mass moment of inertia M_m $\text{kg} \cdot \text{cm}^2$	Recommended INA precision locknut ^{④)}			Required locknut force ^{⑤)} axial ① N	
				For radial locking		For axial locking		Tightening torque ^{⑥)} ① M_A Nm
				①, ②	③	①, ②		
DKLFA1575-2RS	140	5	0,278	ZMA15/33	ZM17	AM15	10	6 270
DKLFA2080-2RS	260	5	0,553	ZMA20/38	ZM25	AM20	18	8 580
DKLFA2590-2RS	370	5	1,12	ZMA25/45	ZM30	AM25	25	9 670
DKLFA30100-2RS	500	5	1,7	ZMA30/52	ZM35	AM30	32	10 350
DKLFA30110-2RS	650	5	3,23	–	ZM35	AM30/65	65	20 500
DKLFA40115-2RS	1 000	5	4,23	ZMA40/62	ZM45	AM40	55	13 420
DKLFA40140-2RS	1 370	5	9,32	–	ZM45	AM40/85	110	26 600

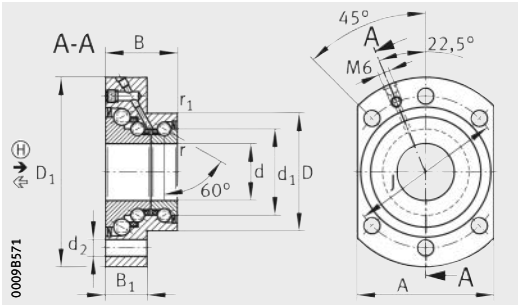

DKLFA..-2RS ($d \geq 25$ mm)

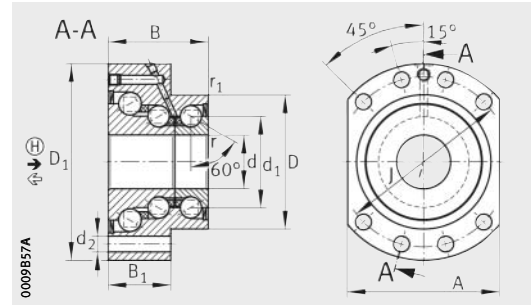

DKLFA..-2RS
Heavy series

Fixing screws ¹⁾ DIN EN ISO 4762		Basic load ratings				Fatigue limit load	Limiting speed	Thermally safe operating speed	Bearing frictional torque	Rigidity	
		axial ←		axial ⊕ →						axial ←	axial →
Size	n	dyn. C _a	stat. C _{0a}	dyn. C _a	stat. C _{0a}	C _u	n _G grease	n _θ	M _R	C _{aL}	C _{aL}
10.9		N	N	N	N	N	min ⁻¹	min ⁻¹	Nm	N/μm	N/μm
M6	4	17 900	28 000	37 000	83 000	2 480	5 700	2 600	0,35	500	950
M6	4	26 000	47 000	44 500	110 000	2 850	5 000	2 200	0,45	750	1 100
M8	6	27 500	55 000	52 000	144 000	4 000	4 400	2 000	0,6	850	1 200
M8	6	29 000	64 000	55 000	165 000	4 550	4 000	1 800	0,75	900	1 400
M8	8	59 000	108 000	106 000	257 000	6 700	3 500	1 600	1,5	1 300	1 600
M8	6	43 000	101 000	73 000	227 000	5 700	3 200	1 500	1	1 100	1 700
M10	8	72 000	149 000	126 000	363 000	9 600	2 900	1 200	2,5	1 800	2 000

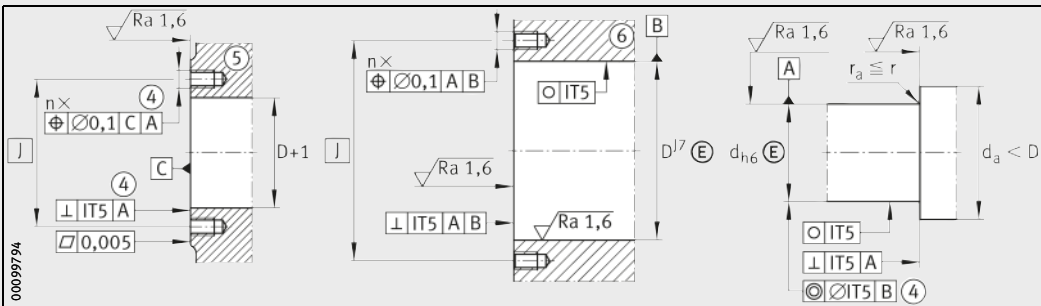

Design of housing and shaft (threaded spindle)

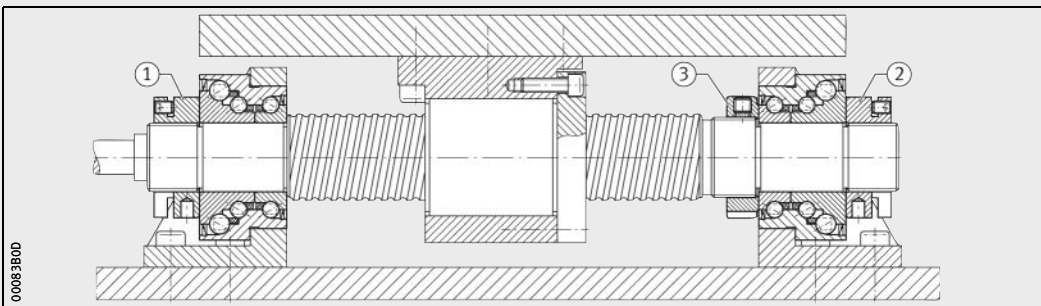

Ball screw drive spindle with locating bearing arrangement on both sides
Numbers in circles: see table INA precision locknuts (accessories), see page 98



Needle roller/axial cylindrical roller bearings

With fixing holes

Without fixing holes

Needle roller/axial cylindrical roller bearings

	Page
Product overview	Needle roller/axial cylindrical roller bearings 102
Features	Radial and axial load carrying capacity..... 103
	Preload and internal clearance..... 103
	Bearings for screw mounting..... 103
	Bearings not for screw mounting 104
	Operating temperature 104
	Suffixes..... 104
Design and safety guidelines	Basic rating life 105
	Static load safety factor 105
	Resultant and equivalent bearing load 106
	Design of adjacent construction..... 108
	Speeds..... 108
	Friction..... 109
	Lubrication 109
	Mounting guidelines..... 111
Accuracy 112
Dimension tables	Needle roller/axial cylindrical roller bearings, light series, with fixing holes 114
	Needle roller/axial cylindrical roller bearings, heavy series, with fixing holes 118
	Needle roller/axial cylindrical roller bearings, light series, without fixing holes 124
	Needle roller/axial cylindrical roller bearings, heavy series, without fixing holes 128



Product overview Needle roller/axial cylindrical roller bearings

With fixing holes

ZARF

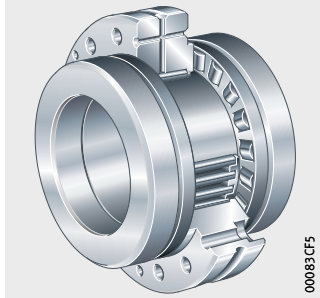

With stepped shaft locating washer extended on one side

ZARF..-L

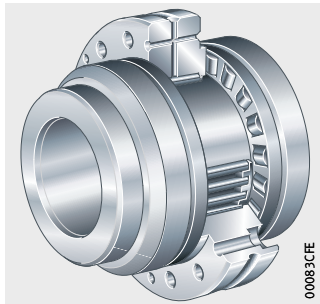

Without fixing holes

ZARN

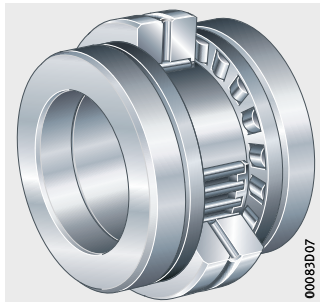

With stepped shaft locating washer extended on one side

ZARN..-L

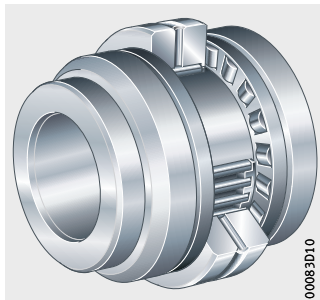

Needle roller/axial cylindrical roller bearings

Features Needle roller/axial cylindrical roller bearings comprise an outer ring with radial and axial raceways, shaft locating washers, an inner ring, a radial needle roller and cage assembly and axial cylindrical roller and cage assemblies. The bearings are available in versions with or without fixing holes.

Radial and axial load carrying capacity In addition to radial forces, the bearings can also support axial forces from both directions and tilting moments.

Preload and internal clearance The outer ring, inner ring and axial cages are matched to each other such that the bearing is axially clearance-free after preloading by means of an INA precision locknut. The radial internal clearance conforms to Group 2 in accordance with ISO 5753-1 (DIN 620-4).

Bearings for screw mounting Needle roller/axial cylindrical roller bearings ZARF(L) have holes in the outer ring. These are used for screw mounting directly on the adjacent construction or in a radial locating bore, *Figure 1*.

Due to screw mounting of the outer ring, the cover that would otherwise be required and the matching work can therefore be dispensed with. The bearings are preloaded against the shaft shoulder by means of a locknut AM or ZM(A).

With seal carrier assembly In the interests of a simpler design, a seal carrier assembly DRS, *Figure 1* is recommended. The seal carrier assembly is centred on the outer ring and seals the bearing against outside influences.

ZARF..-L

- ① Seal carrier assembly DRS
- ② Locknut AM
- ③ Stepped shaft locating washer extended on one side
- ④ Rotary shaft seal DIN 3760-...-NBR

Figure 1
Stepped shaft locating washer with sealing ring

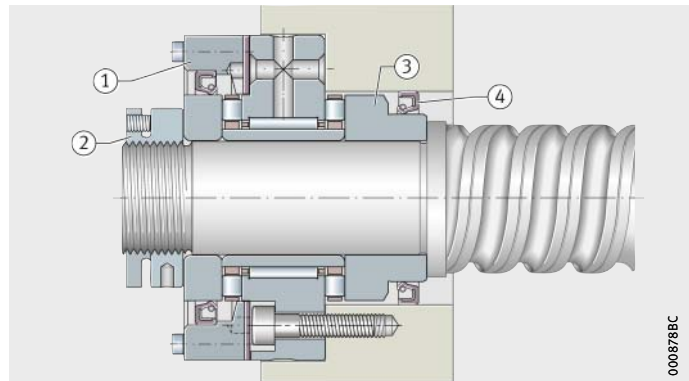

With stepped shaft locating washer ZARF..-L has a stepped shaft locating washer extended on one side, *Figure 1*. These series are used in preference where the shaft locating washers are not adequately supported axially by the shaft shoulder or the bearing unit cannot be sealed on the outside surface of the normal shaft locating washer due to space conditions in the adjacent construction.

Heavy series ZARF(L) is also available in a heavy series. This series has a larger cross-section for the same shaft diameter and therefore higher basic load ratings.

Needle roller/axial cylindrical roller bearings

Bearings not for screw mounting

Bearings ZARN(L) are mounted in a housing bore and the outer ring is located using a cover, *Figure 2*. They are preloaded against the shaft shoulder by means of a locknut AM or ZM(A).

ZARN

① Cover

Figure 2
Bearing outer ring located using cover

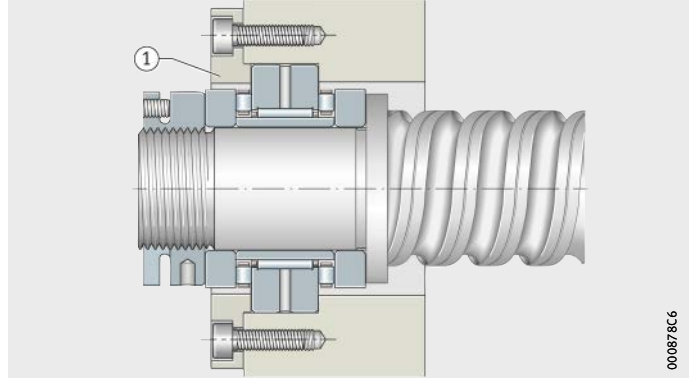

With stepped shaft locating washer

ZARN...L has a stepped shaft locating washer extended on one side, *Figure 3*. This series is used in preference where the shaft locating washer is not adequately supported axially by the shaft shoulder or the bearing unit cannot be sealed on the outside surface of the normal shaft locating washer due to space conditions in the adjacent construction.

ZARN...L

- ① Stepped shaft locating washer extended on one side
- ② Rotary shaft seal DIN 3760

Figure 3
Stepped shaft locating washer with sealing ring

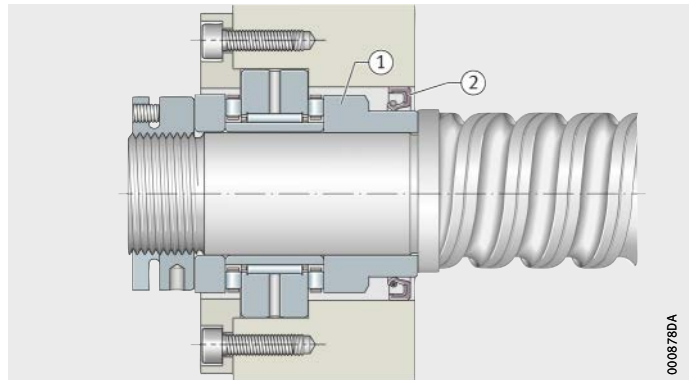

Heavy series

ZARN(L) is also available in a heavy series. This series has a larger cross-section for the same shaft diameter and therefore higher basic load ratings.

Operating temperature

The bearings are suitable for temperatures from -30 °C to $+120\text{ °C}$.

Suffixes

Suffixes for available designs, see table.

Available designs

Suffix	Description	Design
L	Stepped shaft locating washer extended on one side	Standard
TV	Axial bearing cages made from glass fibre reinforced polyamide PA66	

Design and safety guidelines

Basic rating life

The decisive factors in determining the bearing size are the basic rating life, the static load safety factor and the axial limiting load.

The rating life L_{10} or L_{10h} is calculated as follows:

$$L_{10} = \left(\frac{C}{P} \right)^p$$

$$L_{10h} = \frac{16\,666}{n} \cdot \left(\frac{C}{P} \right)^p$$

L_{10} 10^6 revolutions
Basic rating life in millions of revolutions

L_{10h} h
Basic rating life in operating hours

C_r, C_a N
Basic dynamic radial or axial load rating, see dimension tables

C_r is valid for a contact angle $\alpha \leq 45^\circ$,

C_a is valid for a contact angle $\alpha > 45^\circ$

P N
Equivalent dynamic bearing load

p –
Life exponent $p = 10/3$

n min^{-1}
Operating speed.

Static load safety factor

The static load safety factor S_0 indicates the security against impermissible permanent deformations in the bearing, see page 29:

$$S_0 = \frac{C_0}{P_0}$$

S_0 –
Static load safety factor

C_{0r}, C_{0a} N
Basic static radial or axial load rating, see dimension tables

C_{0r} is valid for a contact angle $\alpha \leq 45^\circ$,

C_{0a} is valid for a contact angle $\alpha > 45^\circ$

P_0 N
Maximum static load of bearing.



In machine tools, S_0 should be ≥ 4 .



Needle roller/axial cylindrical roller bearings

Resultant and equivalent bearing load

The resultant axial bearing load $F_{a\ res}$ is determined from the axial operating load F_{aB} and taking account of the axial preload, *Figure 4*, page 107, to *Figure 6*, page 107.

Under pure axial load, $P = F_{a\ res}$. If additional radial operating loads are present, these must be calculated separately using the basic radial load ratings. The limiting loads up to which the axial load can be supported without clearance are shown, *Figure 4*, page 107, to *Figure 6*, page 107.

The needle roller/axial cylindrical roller bearings ZARN and ZARF can be subjected to higher axial preload in order to increase the lift-off load. In this case, it must be taken into consideration that this will cause an increase in friction and temperature as well as a reduction in the basic rating life. The increase in preload is achieved by using a higher tightening torque for the locknut.



In the case of roller bearings, the lift-off load must not be exceeded during highly dynamic acceleration events. As a result, higher wear will occur under rapid acceleration.

For extreme moment loads and statically overdefined systems (locating/locating bearing arrangements), please contact us. The calculation program BEARINX can give a precise design in this case.

Load varying in steps

In this case, P and n are calculated as follows:

$$P = \sqrt[p]{\frac{q_1 \cdot n_1 \cdot P_1^p + \dots + q_z \cdot n_z \cdot P_z^p}{q_1 \cdot n_1 + \dots + q_z \cdot n_z}}$$

$$n = \frac{q_1 \cdot n_1 + \dots + q_z \cdot n_z}{100}$$

P	N
Equivalent dynamic bearing load	
p	-
Life exponent $p = 10/3$	
q	%
Time proportion	
n	min^{-1}
Operating speed.	

F_{aB} = operating load
 $F_{a\text{res}}$ = resultant bearing load
 \circ = limiting load

Figure 4
 Resultant bearing load
 for ZARN, ZARF, light series

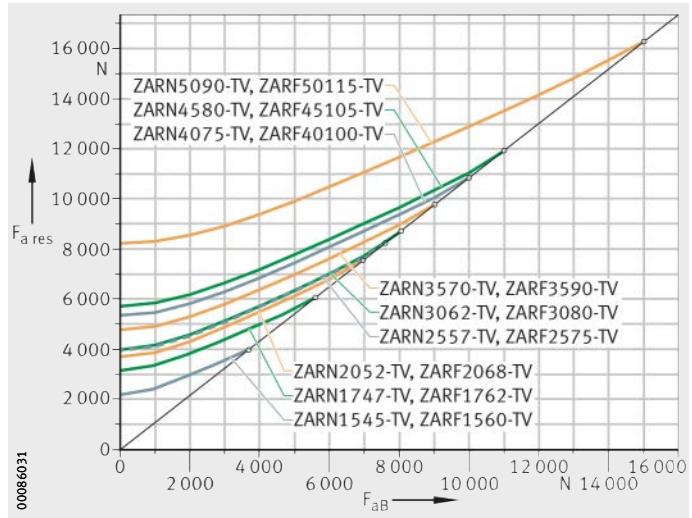

F_{aB} = operating load
 $F_{a\text{res}}$ = resultant bearing load
 \circ = limiting load

Figure 5
 Resultant bearing load
 for ZARN, ZARF, heavy series
 up to $d = 50$ mm

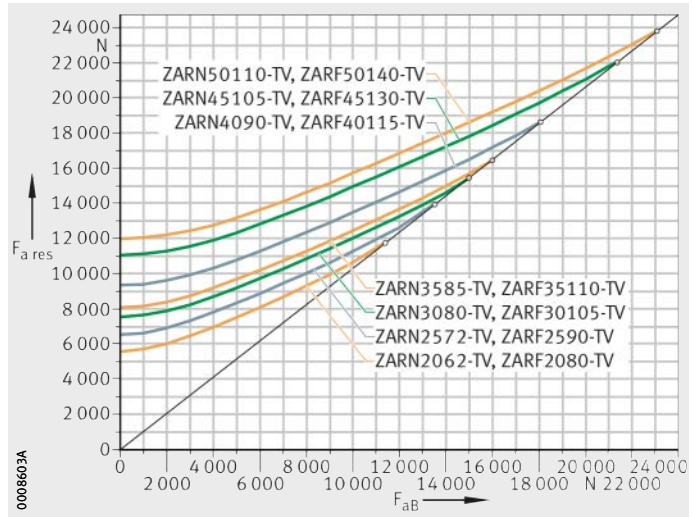

F_{aB} = operating load
 $F_{a\text{res}}$ = resultant bearing load
 \circ = limiting load

Figure 6
 Resultant bearing load
 for ZARN, ZARF, heavy series
 starting from $d = 55$ mm

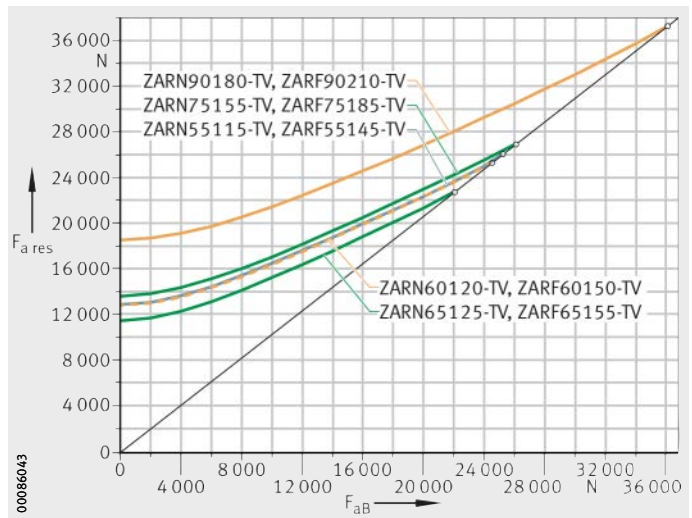

Needle roller/axial cylindrical roller bearings

Design of adjacent construction

The adjacent construction (the shaft and housing) must be designed in accordance with the data in the dimension tables.

The abutment diameters for the shaft and housing shoulders d_a and D_a must be in accordance with the dimension tables.



The permissible contact pressure for the adjacent construction must be observed.

The design of the adjacent construction must include the provision of lubricant feeds, see page 110.

Sealing of the bearing position

The bearings are sealed, *Figure 1*, page 103:

- sealing in the direction of the threaded spindle by a rotary shaft seal on the outside surface machined free from spiral marks of the stepped shaft locating washer (ZARN..-L, ZARF..-L)
- sealing in the direction of the drive by the seal carrier assembly DRS.

Speeds

The limiting speeds n_G given in the dimension tables are based on the following conditions:

- bearing preloaded, no external operating load
- operating duration 25%
- maximum equilibrium temperature +50 °C.



The limiting speeds n_G are valid for oil lubrication with adequate cooling.

Friction In most applications, preloading of bearings by means of the locknut tightening torque gives sufficiently accurate setting values. The reference here is the tightening torque M_A in accordance with the dimension tables in conjunction with an INA precision locknut. The frictional torque M_R given in the dimension tables is a guide value. It is based on lightly oiled bearings, measured at a speed of $n = 5 \text{ min}^{-1}$. For dimensioning of the drive, the starting frictional torque and the frictional torque at high speeds in each case of $2 \cdot M_R$ to $3 \cdot M_R$ must be taken into consideration.

Frictional torque and bearing preload For applications in which the frictional torque is decisive (for example temperature development, frictional torque compensation between different bearing positions, etc.), it is recommended that the bearing preload should be set in accordance with the bearing frictional torque M_R .

Frictional energy The frictional energy N_R of the bearings can be calculated as follows:

$$N_R = \frac{M_R \cdot n}{9,55}$$

N_R Frictional energy W
 M_R Bearing frictional torque Nm
 n Operating speed. min^{-1}

In any analysis of the thermal balance, the various operating speeds n_i must be taken into consideration with their time durations q_i .

Lubrication Needle roller/axial cylindrical roller bearings can be relubricated via the outer ring. They are supplied with oil-based or dry preservative and should preferably be lubricated with oil. Oils CLP to DIN 51517 and HLP to DIN 51524 of viscosity classes ISO VG 32 to ISO VG 100 have proved effective.

Relubrication for grease lubrication Relubrication should be carried out with the bearing rotating and still warm from operation in order to achieve good replacement and distribution of grease.

The relubrication interval and quantity can only be determined under operating conditions since it is not possible to calculate all the influences in advance. For information on relubrication, see TPI 100, Bearings for Screw Drives, Mounting and Maintenance Manual.



Where a vertical axis of rotation is used in conjunction with automatic lubrication systems, the lubrication impulse should be selected such that the supply to the upper axial bearing is sufficient.



Needle roller/axial cylindrical roller bearings

Lubricant feed

In the selection of lubricant feeds for ZARF(L), the mounting position must be observed, *Figure 7* and *Figure 8*.



Before commissioning, it must be ensured that all raceways are adequately supplied with lubricant.

- ZARF..-L**
- ① Oil inlet
 - ② Oil outlet
 - ③ Rotary shaft seal
 - ④ Cover
 - ⑤ Seal carrier assembly

Figure 7
Lubricant feed
for vertical mounting position

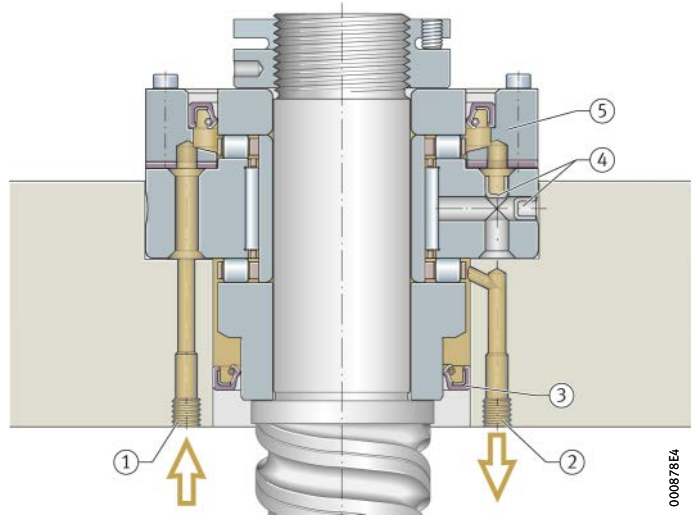

- ZARF..-L**
- ① Oil inlet
 - ② Oil outlet
 - ③ Rotary shaft seal
 - ④ Cover
 - ⑤ Seal carrier assembly

Figure 8
Lubricant feed
for horizontal mounting position

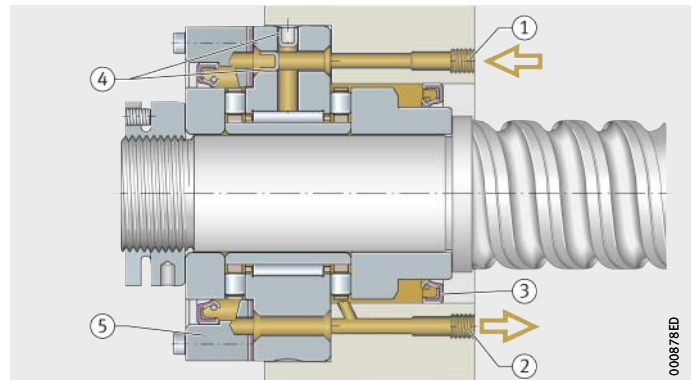

Mounting guidelines

Needle roller/axial cylindrical roller bearings ZARN and ZARF are not self-retaining. The individual bearing components are matched to each other. The individual parts of different bearings must not be interchanged during mounting.

The characteristics of the bearings are only valid when used in combination with INA precision locknuts and the associated tightening torques given in the dimension tables.



During mounting of bearings, mounting forces should be applied only to the bearing ring to be mounted. Mounting forces must never be directed through the rolling elements.

Bearings should only be mounted and dismounted in accordance with the Mounting and Maintenance Manual.

Further information

- TPI 100, Bearings for Screw Drives, Mounting and Maintenance Manual
- Download and ordering: <http://medien.schaeffler.de>.

Setting the axial preload

Since direct force measurement of this value during mounting operation is not cost-effective, the axial preload is set indirectly and using one of the following methods:

- by means of the tightening torque M_A of the precision locknut. The frictional torque may deviate from the value given in the dimension table
- by means of the bearing frictional torque M_R .



The method of setting the preload using the locknut tightening torque is only suitable if a larger frictional torque scatter is permissible and the required calculated rating life is still achieved even with a higher actual preload force, see page 112.

In the axial component of needle roller/axial cylindrical roller bearings ZARF(L), the preload is a decisive factor for correct functioning. It must therefore be set with sufficient accuracy.



Needle roller/axial cylindrical roller bearings

Preloading by locknut

Needle roller/axial cylindrical roller bearings must be axially preloaded during mounting by means of a precision locknut.

Using the locknut tightening torque to set the preload may result in a large preload scatter. Therefore, for applications where the rating life or frictional torque is a critical factor, the setting should be carried out by means of the bearing frictional torque only, or the possible preload fluctuation margin should be included in the rating life calculation.

If the bearing unit is preloaded via the bearing inner rings using the recommended precision locknut, the tightening torques given in the dimension tables must be observed or the preload must be set using the bearing frictional torque given in the dimension tables. The tightening torques given for the individual bearing sizes are only valid for the precision locknuts listed.

For locating/non-locating bearing arrangements and bearing arrangements for rotating ball screw drive nuts, the tightening torques can be taken directly from the dimension tables.

In the case of needle roller/axial cylindrical roller bearings ZARN and ZARF, this tightening torque can be increased if a higher axial limiting load is required. The increase must take account of the increasing bearing friction, increase in bearing temperature and the decreased basic rating life. For information on limit values, please consult Schaeffler.

For locating/locating bearing arrangements, the locknut tightening torques must be calculated by means of BEARINX. In this case, please contact us or use BEARINX-online.

In order to counteract settling, it is recommended that the locknut should initially be tightened to twice the tightening torque M_A and then relieved of load again. It should only then be tightened again to the stated tightening torque M_A . Finally, the precision locknut should be secured against rotation by the torque-controlled tightening of the grub screws.

Fixing screws

For location of the outer ring, screws of grade 10.9 should be used. Screws should be fully tightened with torque control in accordance with the manufacturer's instructions and in a crosswise sequence.

If the bearing outer ring is supported by an additional housing cover, it must be ensured that the fixing screws are sufficiently well dimensioned.

Accuracy

The accuracy of dimensions must be configured as follows:

- axial: tolerance class 4 to ISO 199
- radial: tolerance class 6 to ISO 492.



Needle roller/axial cylindrical roller bearings

Light series
With fixing holes

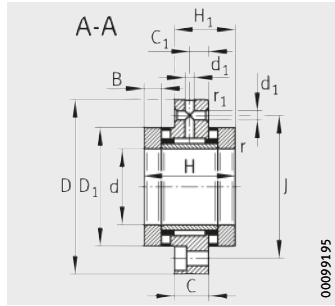

ZARF

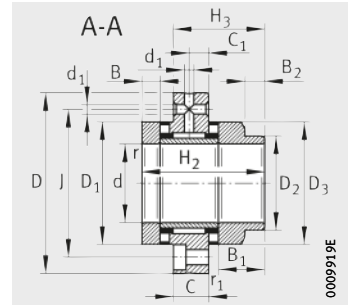

ZARF..-L

Dimension table - Dimensions in mm

Designation	Mass m ≈ kg	Dimensions																	
		d	D	H	H ₁	H ₂	H ₃	C	C ₁	D ₁	D ₂	D ₃	B	B ₁	B ₂	r	r ₁	d ₁	J
ZARF1560-TV	0,42	15	60	40	26	-	-	14	8	35	-	-	7,5	-	-	0,3	0,6	3,2	46
ZARF1560-L-TV	0,45	15	60	-	-	53	39	14	8	35	24	34	7,5	20,5	11	0,3	0,6	3,2	46
ZARF1762-TV	0,49	17	62	43	27,5	-	-	14	8	38	-	-	9	-	-	0,3	0,6	3,2	48
ZARF1762-L-TV	0,52	17	62	-	-	57	41,5	14	8	38	28	38	9	23	11	0,3	0,6	3,2	48
ZARF2068-TV	0,56	20	68	46	29	-	-	14	8	42	-	-	10	-	-	0,3	0,6	3,2	53
ZARF2068-L-TV	0,61	20	68	-	-	60	43	14	8	42	30	40	10	24	12	0,3	0,6	3,2	53
ZARF2575-TV	0,78	25	75	50	33	-	-	18	10	47	-	-	10	-	-	0,3	0,6	3,2	58
ZARF2575-L-TV	0,84	25	75	-	-	65	48	18	10	47	36	45	10	25	12	0,3	0,6	3,2	58
ZARF3080-TV	0,85	30	80	50	33	-	-	18	10	52	-	-	10	-	-	0,3	0,6	3,2	63
ZARF3080-L-TV	0,9	30	80	-	-	65	48	18	10	52	40	50	10	25	13	0,3	0,6	3,2	63

- ① Mounting dimension for seal carrier assembly DRS, see page 146. ③ Adjacent construction, bearing screw mounted in bore.
- ④ Only valid in assembled condition.

- 1) If rotary shaft seals are used, the outside diameter of the sealing ring must be taken into consideration.
- 2) Based on rotating inner ring.
- 3) The recommended INA precision locknuts are not included in the scope of delivery and must be ordered separately.
- 4) The required axial locknut force must be observed when using other locknuts.
- 5) The screws are not included in the scope of delivery. Tightening torque according to manufacturer's data.
- 6) Only valid in conjunction with INA precision locknuts.
Note the guidelines on locating/locating bearing arrangements, see page 54.

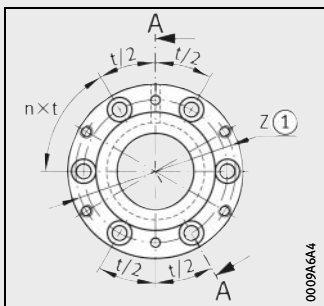

Hole pattern
ZARF1560, ZARF1762

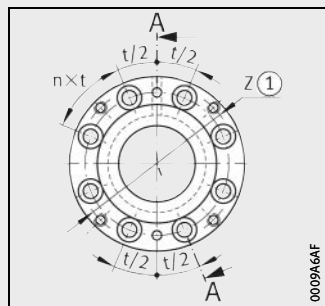

Hole pattern
ZARF2068, ZARF2575

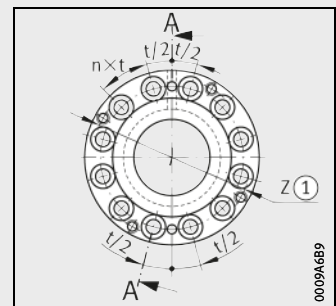

Hole pattern
ZARF3080

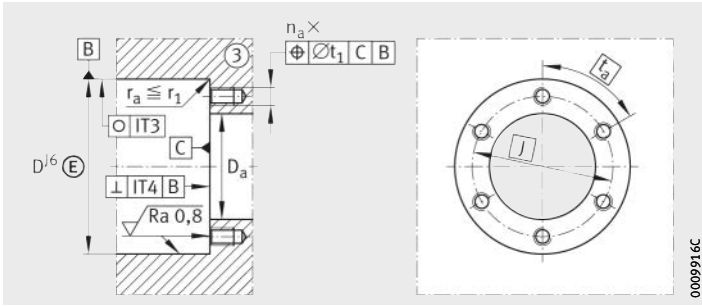

Housing design

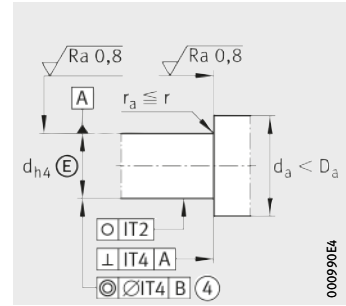

Shaft design
(threaded spindle)

Pitch	Mounting dimensions ¹⁾			Basic load ratings				Fatigue limit loads		Limiting speeds		Bearing frictional torque	Rigidity
				axial		radial		axial	radial				
	D _a	d _a	t ₁	dyn. C _a	stat. C _{0a}	dyn. C _r	stat. C _{0r}	C _{ua}	C _{ur}	n _G oil	n _G grease		
max.	min.		N	N	N	N	N	N	min ⁻¹	min ⁻¹	Nm	N/μm	
6×60°	36	28	0,1	24 900	53 000	13 000	17 500	7 300	2 600	8 500	2 200	0,35	1 400
6×60°	36	22	0,1	24 900	53 000	13 000	17 500	7 300	2 600	8 500	2 200	0,35	1 400
6×60°	39	28	0,1	26 000	57 000	14 000	19 900	7 900	2 950	7 800	2 100	0,4	1 600
6×60°	39	26	0,1	26 000	57 000	14 000	19 900	7 900	2 950	7 800	2 100	0,4	1 600
8×45°	43	33	0,1	33 500	76 000	14 900	22 400	6 300	3 350	7 000	2 000	0,5	1 800
8×45°	43	28	0,1	33 500	76 000	14 900	22 400	6 300	3 350	7 000	2 000	0,5	1 800
8×45°	48	39	0,1	35 500	86 000	22 600	36 000	7 100	5 100	6 000	1 900	0,55	1 900
8×45°	48	34	0,1	35 500	86 000	22 600	36 000	7 100	5 100	6 000	1 900	0,55	1 900
12×30°	53	44	0,1	39 000	101 000	24 300	41 500	8 400	5 900	5 500	1 800	0,65	2 200
12×30°	53	38	0,1	39 000	101 000	24 300	41 500	8 400	5 900	5 500	1 800	0,65	2 200

Dimension table (continued) · Dimensions in mm

Designation	Tilting rigidity	Mass moment of inertia ²⁾	Axial runout ²⁾	Recommended INA precision locknut ³⁾			Required locknut force ⁴⁾	Rotary shaft seal to DIN 3760; to be ordered separately	Fixing screws ⁵⁾	
				For radial locking	For axial locking	Tightening torque ⁶⁾			Size	n _a ×t _a
	c _{kL}	M _m	μm			M _A	N			
	Nm/mrad	kg · cm ²				Nm				
ZARF1560-TV	110	0,24	1	ZMA15/33	AM15	10	6 506	–	M6	6×60°
ZARF1560-L-TV	110	0,274	1	ZMA15/33	AM15	10	6 506	24×35×7	M6	6×60°
ZARF1762-TV	160	0,373	1	ZM17	AM17	12	7 078	–	M6	6×60°
ZARF1762-L-TV	160	0,464	1	ZM17	AM17	12	7 078	28×40×7	M6	6×60°
ZARF2068-TV	230	0,615	1	ZMA20/38	AM20	18	8 972	–	M6	8×45°
ZARF2068-L-TV	230	0,683	1	ZMA20/38	AM20	18	8 972	30×42×7	M6	8×45°
ZARF2575-TV	350	0,989	1	ZMA25/45	AM25	25	9 745	–	M6	8×45°
ZARF2575-L-TV	350	1,15	1	ZMA25/45	AM25	25	9 745	36×47×7	M6	8×45°
ZARF3080-TV	520	1,46	1	ZMA30/52	AM30	32	10 662	–	M6	12×30°
ZARF3080-L-TV	520	1,7	1	ZMA30/52	AM30	32	10 662	40×52×7	M6	12×30°

Needle roller/axial cylindrical roller bearings

Light series
With fixing holes

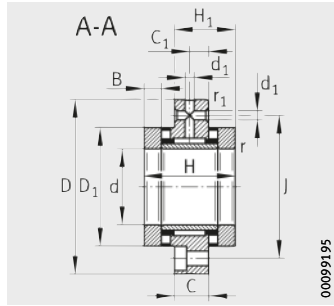

ZARF

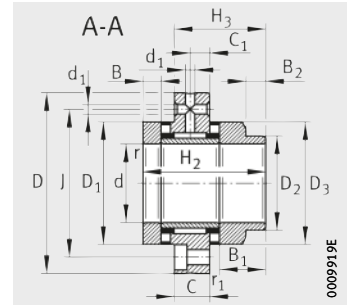

ZARF..-L

Dimension table (continued) · Dimensions in mm

Designation	Mass m ≈ kg	Dimensions																	
		d	D	H	H ₁	H ₂	H ₃	C	C ₁	D ₁	D ₂	D ₃	B	B ₁	B ₂	r	r ₁	d ₁	J
ZARF3590-TV	1,12	35	90	54	35	-	-	18	10	60	-	-	11	-	-	0,3	0,6	3,2	73
ZARF3590-L-TV	1,25	35	90	-	-	70	51	18	10	60	45	58	11	27	13	0,3	0,6	3,2	73
ZARF40100-TV	1,35	40	100	54	35	-	-	18	10	65	-	-	11	-	-	0,3	0,6	3,2	80
ZARF40100-L-TV	1,45	40	100	-	-	70	51	18	10	65	50	63	11	27	14	0,3	0,6	3,2	80
ZARF45105-TV	1,7	45	105	60	40	-	-	22,5	12,5	70	-	-	11,5	-	-	0,3	0,6	6	85
ZARF45105-L-TV	1,85	45	105	-	-	75	55	22,5	12,5	70	56	68	11,5	26,5	13	0,3	0,6	6	85
ZARF50115-TV	2,1	50	115	60	40	-	-	22,5	12,5	78	-	-	11,5	-	-	0,3	0,6	6	94
ZARF50115-L-TV	2,45	50	115	-	-	78	58	22,5	12,5	78	60	78	11,5	29,5	14	0,3	0,6	6	94

- ① Mounting dimension for seal carrier assembly DRS, see page 146. ③ Adjacent construction, bearing screw mounted in bore.
- ④ Only valid in assembled condition.

- 1) If rotary shaft seals are used, the outside diameter of the sealing ring must be taken into consideration.
- 2) Based on rotating inner ring.
- 3) The recommended INA precision locknuts are not included in the scope of delivery and must be ordered separately.
- 4) The required axial locknut force must be observed when using other locknuts.
- 5) Tightening torque of fixing screws according to manufacturer's data. The screws are not included in the scope of delivery.
- 6) Only valid in conjunction with INA precision locknuts. Note the guidelines on locating/locating bearing arrangements, see page 54.

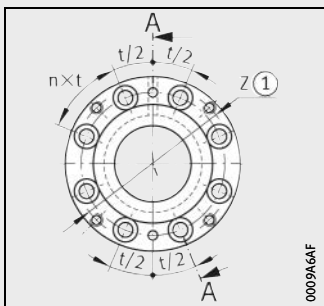

Hole pattern
ZARF40100, ZARF45105

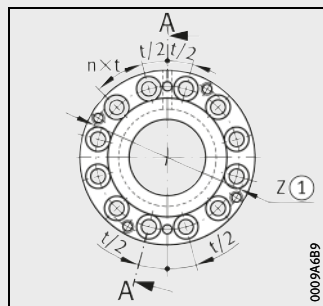

Hole pattern
ZARF3590, ZARF50115

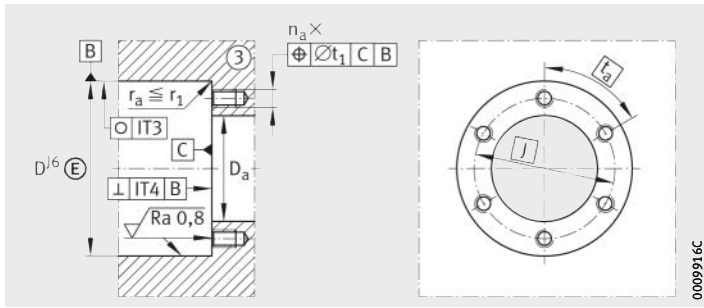

Housing design

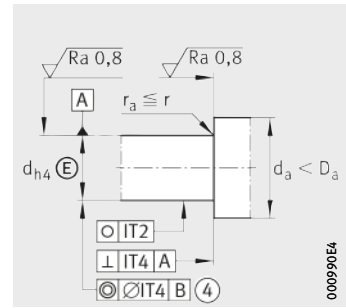

Shaft design
(threaded spindle)

Pitch	Mounting dimensions ¹⁾			Basic load ratings				Fatigue limit loads		Limiting speeds		Bearing frictional torque	Rigidity
				axial		radial		axial	radial				
	D _a max.	d _a min.	t ₁	dyn. C _a N	stat. C _{0a} N	dyn. C _r N	stat. C _{0r} N	C _{ua} N	C _{ur} N	n _G oil min ⁻¹	n _G grease min ⁻¹		
12×30°	61	50	0,1	56 000	148 000	26 000	47 000	12 800	6 700	4 800	1 700	0,9	2 600
12×30°	61	43	0,1	56 000	148 000	26 000	47 000	12 800	6 700	4 800	1 700	0,9	2 600
8×45°	66	55	0,2	59 000	163 000	27 500	53 000	14 100	7 500	4 400	1 600	1	2 800
8×45°	66	48	0,2	59 000	163 000	27 500	53 000	14 100	7 500	4 400	1 600	1	2 800
8×45°	71	60	0,2	61 000	177 000	38 000	74 000	15 400	10 200	4 000	1 500	1,2	3 000
8×45°	71	54	0,2	61 000	177 000	38 000	74 000	15 400	10 200	4 000	1 500	1,2	3 000
12×30°	79	67	0,2	90 000	300 000	40 000	82 000	27 500	11 300	3 600	1 200	2,2	4 800
12×30°	79	58	0,2	90 000	300 000	40 000	82 000	27 500	11 300	3 600	1 200	2,2	4 800

Dimension table (continued) · Dimensions in mm

Designation	Tilting rigidity c _{kL} Nm/mrad	Mass moment of inertia ²⁾ M _m kg · cm ²	Axial runout ²⁾ μm	Recommended INA precision locknut ³⁾			Required locknut force ⁴⁾ axial N	Rotary shaft seal to DIN 3760; to be ordered separately	Fixing screws ⁵⁾ DIN EN ISO 4762 10.9	
				For radial locking	For axial locking	Tightening torque ⁶⁾ M _A Nm			Size	n _a × t _a
ZARF3590-TV	740	2,8	1	ZMA35/58	AM35/58	40	12 143	–	M6	12×30°
ZARF3590-L-TV	740	3,21	1	ZMA35/58	AM35/58	40	12 143	45×60×8	M6	12×30°
ZARF40100-TV	1 030	3,78	1	ZMA40/62	AM40	55	14 240	–	M8	8×45°
ZARF40100-L-TV	1 030	4,35	1	ZMA40/62	AM40	55	14 240	50×65×8	M8	8×45°
ZARF45105-TV	1 340	5,33	1	ZMA45/68	AM45	65	15 112	–	M8	8×45°
ZARF45105-L-TV	1 340	6,03	1	ZMA45/68	AM45	65	15 112	56×70×8	M8	8×45°
ZARF50115-TV	2 470	8,42	1	ZMA50/75	AM50	85	18 410	–	M8	12×30°
ZARF50115-L-TV	2 470	10,46	1	ZMA50/75	AM50	85	18 410	60×80×8	M8	12×30°



Needle roller/axial cylindrical roller bearings

Heavy series
With fixing holes

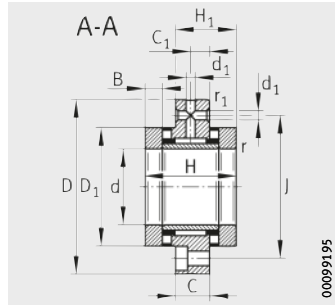

ZARF

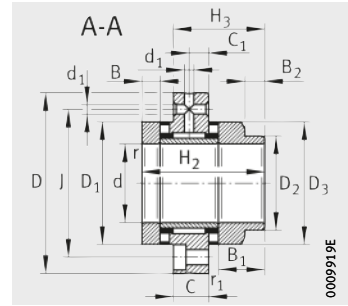

ZARF..-L

Dimension table - Dimensions in mm

Designation	Mass m ≈ kg	Dimensions																	
		d	D	H	H ₁	H ₂	H ₃	C	C ₁	D ₁	D ₂	D ₃	B	B ₁	B ₂	r	r ₁	d ₁	J
ZARF2080-TV	1,1	20	80	60	38	-	-	18	10	52	-	-	12,5	-	-	0,3	0,6	3,2	63
ZARF2080-L-TV	1,22	20	80	-	-	75	53	18	10	52	40	50	12,5	27,5	13	0,3	0,6	3,2	63
ZARF2590-TV	1,6	25	90	60	38	-	-	18	10	62	-	-	12,5	-	-	0,3	0,6	3,2	73
ZARF2590-L-TV	1,75	25	90	-	-	75	53	18	10	62	48	60	12,5	27,5	13	0,3	0,6	3,2	73
ZARF30105-TV	1,95	30	105	66	41	-	-	18	10	68	-	-	14	-	-	0,3	0,6	3,2	85
ZARF30105-L-TV	2,15	30	105	-	-	82	57	18	10	68	52	66	14	30	13	0,3	0,6	3,2	85
ZARF35110-TV	1,6	35	110	66	41	-	-	18	10	73	-	-	14	-	-	0,3	0,6	3,2	88
ZARF35110-L-TV	1,85	35	110	-	-	82	57	18	10	73	60	73	14	30	13	0,3	0,6	3,2	88
ZARF40115-TV	2,7	40	115	75	47,5	-	-	22,5	12,5	78	-	-	16	-	-	0,3	0,6	6	94
ZARF40115-L-TV	3	40	115	-	-	93	65,5	22,5	12,5	78	60	78	16	34	14	0,3	0,6	6	94
ZARF45130-TV	3,9	45	130	82	51	-	-	22,5	12,5	90	-	-	17,5	-	-	0,3	0,6	6	105
ZARF45130-L-TV	4,3	45	130	-	-	103	72	22,5	12,5	90	70	88	17,5	38,5	18	0,3	0,6	6	105

- ① Mounting dimension for seal carrier assembly DRS, see page 146.
- ③ Adjacent construction, bearing screw mounted in bore.
- ④ Only valid in assembled condition.

- 1) If rotary shaft seals are used, the outside diameter of the sealing ring must be taken into consideration.
- 2) Based on rotating inner ring.
- 3) The recommended INA precision locknuts are not included in the scope of delivery and must be ordered separately.
- 4) The required axial locknut force must be observed when using other locknuts.
- 5) Tightening torque of fixing screws according to manufacturer's data.
The screws are not included in the scope of delivery.
- 6) Only valid in conjunction with INA precision locknuts.
Note the guidelines on locating/locating bearing arrangements, see page 54.

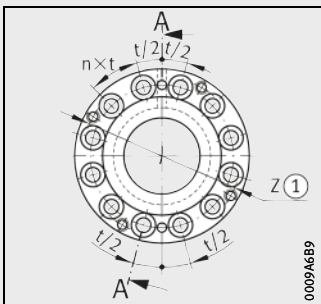

Hole pattern

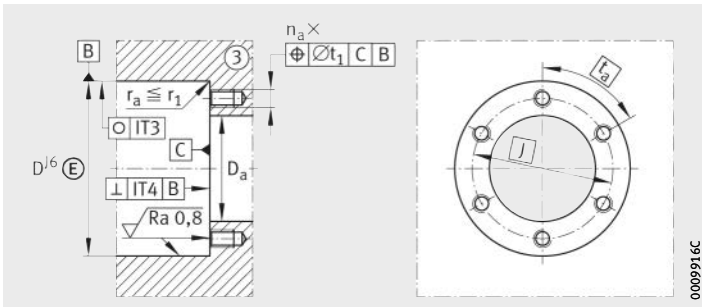

Housing design

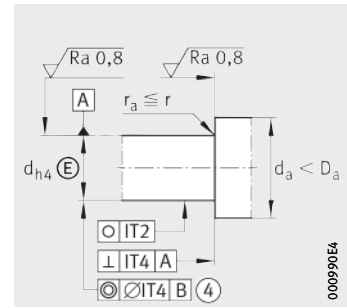

Shaft design
(threaded spindle)

Pitch	Mounting dimensions ¹⁾			Basic load ratings				Fatigue limit loads		Limiting speeds		Bearing frictional torque	Rigidity
				axial		radial		axial	radial				
	D _a max.	d _a min.	t ₁	dyn. C _a N	stat. C _{0a} N	dyn. C _r N	stat. C _{0r} N	C _{ua} N	C _{ur} N	n _G oil min ⁻¹	n _G grease min ⁻¹		
12×30°	53	38	0,1	64 000	141 000	22 600	36 000	12 900	5 100	6 000	1 500	1,3	2 300
12×30°	53	38	0,1	64 000	141 000	22 600	36 000	12 900	5 100	6 000	1 500	1,3	2 300
12×30°	63	45	0,1	80 000	199 000	24 300	41 500	18 300	5 900	4 900	1 400	1,6	3 000
12×30°	63	45	0,1	80 000	199 000	24 300	41 500	18 300	5 900	4 900	1 400	1,6	3 000
12×30°	69	52	0,2	107 000	265 000	26 000	47 000	22 500	6 700	4 400	1 300	2,1	3 300
12×30°	69	50	0,2	107 000	265 000	26 000	47 000	22 500	6 700	4 400	1 300	2,1	3 300
12×30°	74	60	0,2	105 000	265 000	27 500	53 000	22 500	7 500	4 000	1 250	2,3	3 500
12×30°	74	58	0,2	105 000	265 000	27 500	53 000	22 500	7 500	4 000	1 250	2,3	3 500
12×30°	79	65	0,2	117 000	315 000	38 000	74 000	26 500	10 200	3 700	1 200	2,5	3 800
12×30°	79	58	0,2	117 000	315 000	38 000	74 000	26 500	10 200	3 700	1 200	2,5	3 800
12×30°	91	70	0,2	154 000	405 000	40 000	82 000	36 500	11 300	3 300	1 150	3,5	4 000
12×30°	91	68	0,2	154 000	405 000	40 000	82 000	36 500	11 300	3 300	1 150	3,5	4 000

Dimension table (continued) - Dimensions in mm

Designation	Tilting rigidity	Mass moment of inertia ²⁾	Axial runout ²⁾	Recommended INA precision locknut ³⁾			Required locknut force ⁴⁾	Rotary shaft seal to DIN EN 3760; to be ordered separately	Fixing screws ⁵⁾	
				For radial locking	For axial locking	Tightening torque ⁶⁾			Size	n _a ×t _a
	c _{kL} Nm/mrad	M _m kg·cm ²	μm			M _A Nm	N			
ZARF2080-TV	400	1,98	1	ZMA20/52	AM20	38	17 623	–	M6	12×30°
ZARF2080-L-TV	400	2,27	1	ZMA20/52	AM20	38	17 623	40×52×7	M6	12×30°
ZARF2590-TV	800	3,88	1	ZMA25/58	AM25	55	20 790	–	M6	12×30°
ZARF2590-L-TV	800	4,51	1	ZMA25/58	AM25	55	20 790	48×62×8	M6	12×30°
ZARF30105-TV	1 100	6,53	1	ZMA30/65	AM30	75	24 287	–	M8	12×30°
ZARF30105-L-TV	1 100	7,43	1	ZMA30/65	AM30	75	24 287	52×68×8	M8	12×30°
ZARF35110-TV	1 300	8,47	1	ZMA35/70	AM35	100	27 480	–	M8	12×30°
ZARF35110-L-TV	1 300	10,4	1	ZMA35/70	AM35	100	27 480	60×75×8	M8	12×30°
ZARF40115-TV	1 800	13,3	1	ZMA40/75	AM40	120	29 834	–	M8	12×30°
ZARF40115-L-TV	1 800	15,5	1	ZMA40/75	AM40	120	29 834	60×80×8	M8	12×30°
ZARF45130-TV	2 100	23,7	1	ZMA45/85	AM45	150	33 549	–	M8	12×30°
ZARF45130-L-TV	2 100	28,1	1	ZMA45/85	AM45	150	33 549	70×90×10	M8	12×30°

Needle roller/axial cylindrical roller bearings

Heavy series
With fixing holes

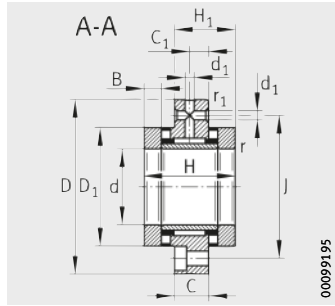

ZARF

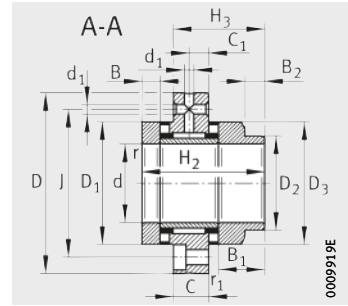

ZARF..-L

Dimension table (continued) · Dimensions in mm

Designation	Mass m ≈ kg	Dimensions																	
		d	D	H	H ₁	H ₂	H ₃	C	C ₁	D ₁	D ₂	D ₃	B	B ₁	B ₂	r	r ₁	d ₁	J
ZARF50140-TV	4,2	50	140	82	51	–	–	22,5	12,5	95	–	–	17,5	–	–	0,3	0,6	6	113
ZARF50140-L-TV	4,65	50	140	–	–	103	72	22,5	12,5	95	75	93	17,5	38,5	18	0,3	0,6	6	113
ZARF55145-TV	4,5	55	145	82	51	–	–	22,5	12,5	100	–	–	17,5	–	–	0,3	0,6	6	118
ZARF55145-L-TV	5	55	145	–	–	103	72	22,5	12,5	100	80	98	17,5	38,5	18	0,3	0,6	6	118
ZARF60150-TV	4,7	60	150	82	51	–	–	22,5	12,5	105	–	–	17,5	–	–	0,3	0,6	6	123
ZARF60150-L-TV	5,35	60	150	–	–	103	72	22,5	12,5	105	90	105	17,5	38,5	18	0,3	0,6	6	123
ZARF65155-TV	5,1	65	155	82	51	–	–	22,5	12,5	110	–	–	17,5	–	–	0,3	0,6	6	128
ZARF65155-L-TV	5,7	65	155	–	–	103	72	22,5	12,5	110	90	108	17,5	38,5	18	0,3	0,6	6	128

- ① Mounting dimension for seal carrier assembly DRS, see page 146. ③ Adjacent construction, bearing screw mounted in bore.
- ④ Only valid in assembled condition.

- 1) If rotary shaft seals are used, the outside diameter of the sealing ring must be taken into consideration.
- 2) Based on rotating inner ring.
- 3) The recommended INA precision locknuts are not included in the scope of delivery and must be ordered separately.
- 4) The required axial locknut force must be observed when using other locknuts.
- 5) Tightening torque of fixing screws according to manufacturer's data.
The screws are not included in the scope of delivery.
- 6) Only valid in conjunction with INA precision locknuts.
Note the guidelines on locating/locating bearing arrangements, see page 54.

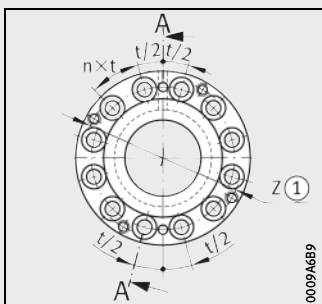

Hole pattern
ZARF5, ZARF6

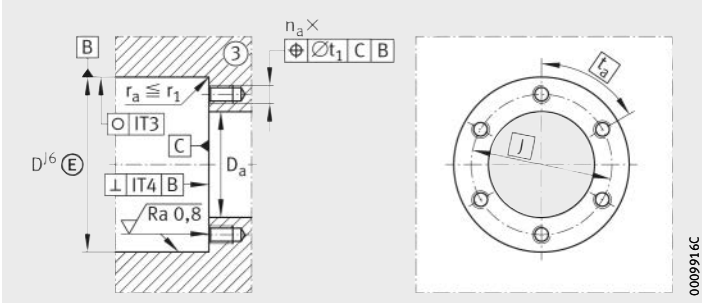

Housing design

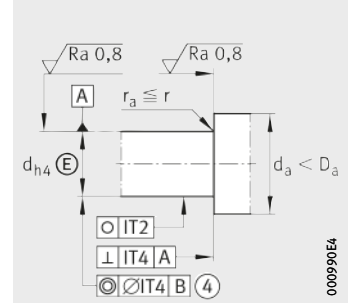

Shaft design
(threaded spindle)

Pitch	Mounting dimensions ¹⁾			Basic load ratings				Fatigue limit loads		Limiting speeds		Bearing frictional torque	Rigidity
				axial		radial		axial	radial				
n×t	D _a	d _a	t ₁	dyn. C _a	stat. C _{0a}	dyn. C _r	stat. C _{0r}	C _{ua}	C _{ur}	n _G oil	n _G grease	M _R	axial C _{aL}
	max.	min.		N	N	N	N	N	N	min ⁻¹	min ⁻¹	Nm	N/μm
12×30°	96	75	0,2	172 000	480 000	42 000	90 000	43 500	12 400	3 100	1 100	3,8	4 600
12×30°	96	73	0,2	172 000	480 000	42 000	90 000	43 500	12 400	3 100	1 100	3,8	4 600
12×30°	101	85	0,2	177 000	500 000	44 000	98 000	46 000	13 500	2 900	1 000	4	4 900
12×30°	101	78	0,2	177 000	500 000	44 000	98 000	46 000	13 500	2 900	1 000	4	4 900
12×30°	106	90	0,2	187 000	550 000	44 500	92 000	50 000	12 600	2 700	950	4,2	5 300
12×30°	106	88	0,2	187 000	550 000	44 500	92 000	50 000	12 600	2 700	950	4,2	5 300
12×30°	111	97	0,2	172 000	500 000	54 000	104 000	46 000	14 600	2 600	900	4	4 800
12×30°	111	88	0,2	172 000	500 000	54 000	104 000	46 000	14 600	2 600	900	4	4 800

Dimension table (continued) · Dimensions in mm

Designation	Tilting rigidity	Mass moment of inertia ²⁾	Axial runout ²⁾	Recommended INA precision locknut ³⁾			Required locknut force ⁴⁾	Rotary shaft seal to DIN 3760; to be ordered separately	Fixing screws ⁵⁾	
				For radial locking	For axial locking	Tightening torque ⁶⁾			Size	n _a ×t _a
	c _{kL}	M _m	μm			M _A	N			
ZARF50140-TV	2 900	29,8	1	ZMA50/92	AM50	180	36 224	-	M10	12×30°
ZARF50140-L-TV	2 900	35,3	1	ZMA50/92	AM50	180	36 224	75×95×10	M10	12×30°
ZARF55145-TV	3 600	36,1	1	ZMA55/98	AM55	220	39 807	-	M10	12×30°
ZARF55145-L-TV	3 600	43	1	ZMA55/98	AM55	220	39 807	80×100×10	M10	12×30°
ZARF60150-TV	4 300	43,8	1	ZMA60/98	AM60	250	41 144	-	M10	12×30°
ZARF60150-L-TV	4 300	54,5	1	ZMA60/98	AM60	250	41 144	90×110×12	M10	12×30°
ZARF65155-TV	4 000	51	1	ZMA65/105	AM65	270	40 652	-	M10	12×30°
ZARF65155-L-TV	4 000	60,1	1	ZMA65/105	AM65	270	40 652	90×110×12	M10	12×30°



Needle roller/axial cylindrical roller bearings

Heavy series
With fixing holes

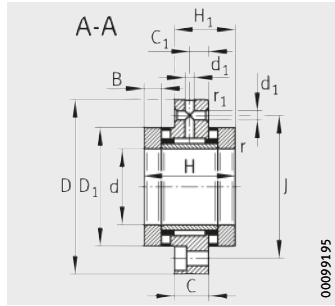

ZARF

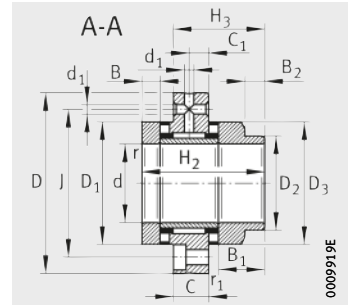

ZARF..-L

Dimension table (continued) · Dimensions in mm

Designation	Mass m ≈ kg	Dimensions																	
		d	D	H	H ₁	H ₂	H ₃	C	C ₁	D ₁	D ₂	D ₃	B	B ₁	B ₂	r	r ₁	d ₁	J
ZARF70160-TV	5,2	70	160	82	51	-	-	22,5	12,5	115	-	-	17,5	-	-	0,3	0,6	6	133
ZARF70160-L-TV	5,95	70	160	-	-	103	72	22,5	12,5	115	100	115	17,5	38,5	18	0,3	0,6	6	133
ZARF75185-TV	9,4	75	185	100	62	-	-	27	15	135	-	-	21	-	-	0,3	1	6	155
ZARF75185-L-TV	10,6	75	185	-	-	125	87	27	15	135	115	135	21	46	20	0,3	1	6	155
ZARF90210-TV	13,7	90	210	110	69,5	-	-	32	17,5	160	-	-	22,5	-	-	0,3	1	8	180
ZARF90210-L-TV	15,1	90	210	-	-	135	94,5	32	17,5	160	130	158	22,5	47,5	18	0,3	1	8	180

① Mounting dimension for seal carrier assembly DRS, see page 146. ③ Adjacent construction, bearing screw mounted in bore.
④ Only valid in assembled condition.

- 1) If rotary shaft seals are used, the outside diameter of the sealing ring must be taken into consideration.
- 2) Based on rotating inner ring.
- 3) The recommended INA precision locknuts are not included in the scope of delivery and must be ordered separately.
- 4) The required axial locknut force must be observed when using other locknuts.
- 5) Tightening torque of fixing screws according to manufacturer's data.
The screws are not included in the scope of delivery.
- 6) Only valid in conjunction with INA precision locknuts.
Note the guidelines on locating/locating bearing arrangements, see page 54.

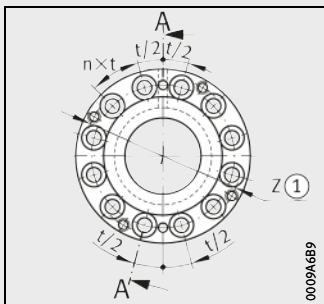

Hole pattern
ZARF7

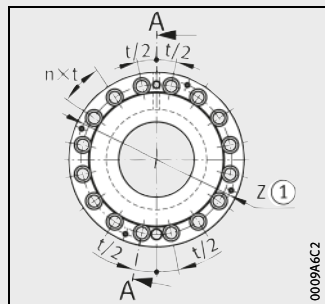

Hole pattern
ZARF90210

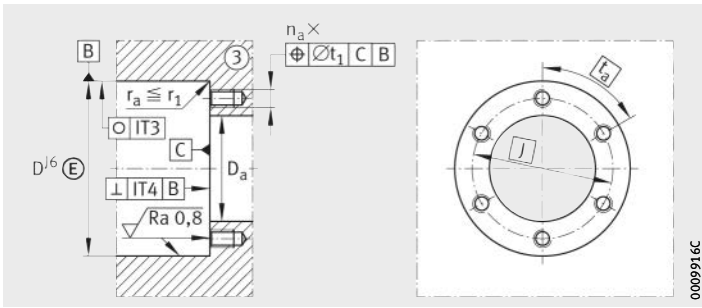

Housing design

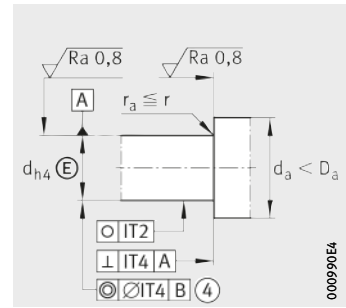

Shaft design
(threaded spindle)

Pitch	Mounting dimensions ¹⁾			Basic load ratings				Fatigue limit loads		Limiting speeds		Bearing frictional torque	Rigidity
				axial		radial		axial	radial				
	D _a	d _a	t ₁	dyn. C _a	stat. C _{0a}	dyn. C _r	stat. C _{0r}	C _{ua}	C _{ur}	n _G oil	n _G grease		
max.	min.		N	N	N	N	N	N	min ⁻¹	min ⁻¹	Nm	N/μm	
12×30°	116	100	0,2	201 000	630 000	56 000	119 000	57 000	15 800	2 400	800	4,8	5 800
12×30°	116	98	0,2	201 000	630 000	56 000	119 000	57 000	15 800	2 400	800	4,8	5 800
12×30°	136	113	0,4	290 000	890 000	72 000	132 000	84 000	18 800	2 100	700	8	6 600
12×30°	136	110	0,4	290 000	890 000	72 000	132 000	84 000	18 800	2 100	700	8	6 600
16×22,5°	161	130	0,4	325 000	1 030 000	98 000	210 000	93 000	28 500	1 800	700	10,5	7 700
16×22,5°	161	125	0,4	325 000	1 030 000	98 000	210 000	93 000	28 500	1 800	700	10,5	7 700

Dimension table (continued) · Dimensions in mm

Designation	Tilting rigidity	Mass moment of inertia ²⁾	Axial run-out ²⁾	Recommended INA precision			Required locknut force ⁴⁾	Rotary shaft seal to DIN 3760; to be ordered separately	Fixing screws ⁵⁾	
				For radial locking	For axial locking	Tightening torque ⁶⁾			Size	n _a ×t _a
	c _{kL}	M _m	μm			M _A	axial			
	Nm/mrad	kg · cm ²				Nm	N			
ZARF70160-TV	6 000	62,2	1	ZMA70/110	AM70	330	46 786	–	M10	12×30°
ZARF70160-L-TV	6 000	77,3	1	ZMA70/110	AM70	330	46 786	100×120×12	M10	12×30°
ZARF75185-TV	8 500	149	2	ZMA75/125	AM75	580	72 971	–	M12	12×30°
ZARF75185-L-TV	8 500	188	2	ZMA75/125	AM75	580	72 971	115×140×12	M12	12×30°
ZARF90210-TV	14 500	312	2	ZMA90/155	AM90	960	100 669	–	M12	16×22,5°
ZARF90210-L-TV	14 500	372	2	ZMA90/155	AM90	960	100 669	130×160×12	M12	16×22,5°



Needle roller/axial cylindrical roller bearings

Light series
Without fixing holes

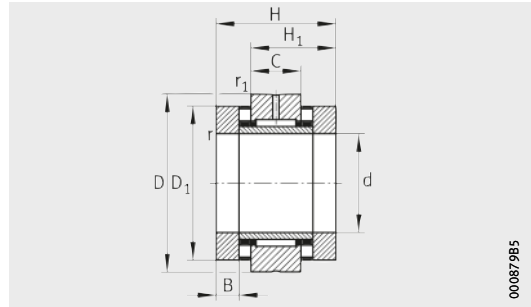

ZARN

000879B5

Dimension table - Dimensions in mm

Designation	Mass m ≈ kg	Dimensions														
		d	D	H	H ₁	H ₂	H ₃	C	D ₁	D ₂	D ₃	B	B ₁	B ₂	r min.	r ₁ min.
ZARN1545-TV	0,34	15	45	40	28	–	–	16	35	–	–	7,5	–	–	0,3	0,6
ZARN1545-L-TV	0,37	15	45	–	–	53	41	16	35	24	34	7,5	20,5	11	0,3	0,6
ZARN1747-TV	0,37	17	47	43	29,5	–	–	16	38	–	–	9	–	–	0,3	0,6
ZARN1747-L-TV	0,41	17	47	–	–	57	43,5	16	38	28	38	9	23	11	0,3	0,6
ZARN2052-TV	0,41	20	52	46	31	–	–	16	42	–	–	10	–	–	0,3	0,6
ZARN2052-L-TV	0,46	20	52	–	–	60	45	16	42	30	40	10	24	12	0,3	0,6
ZARN2557-TV	0,53	25	57	50	35	–	–	20	47	–	–	10	–	–	0,3	0,6
ZARN2557-L-TV	0,59	25	57	–	–	65	50	20	47	36	45	10	25	12	0,3	0,6
ZARN3062-TV	0,6	30	62	50	35	–	–	20	52	–	–	10	–	–	0,3	0,6
ZARN3062-L-TV	0,75	30	62	–	–	65	50	20	52	40	50	10	25	13	0,3	0,6

④ Only valid in assembled condition.

- 1) If rotary shaft seals are used, the outside diameter of the sealing ring must be taken into consideration.
- 2) Based on rotating inner ring.
- 3) The recommended INA precision locknuts are not included in the scope of delivery and must be ordered separately.
- 4) The required axial locknut force must be observed when using other locknuts.
- 5) Only valid in conjunction with INA precision locknuts.
Note the guidelines on locating/locating bearing arrangements, see page 54.

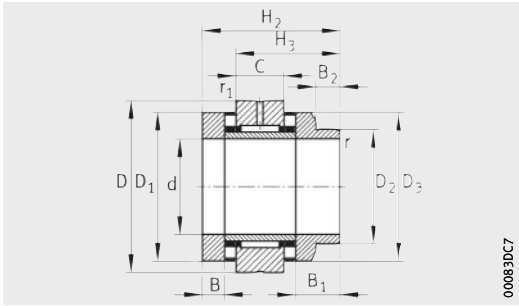

ZARN..L

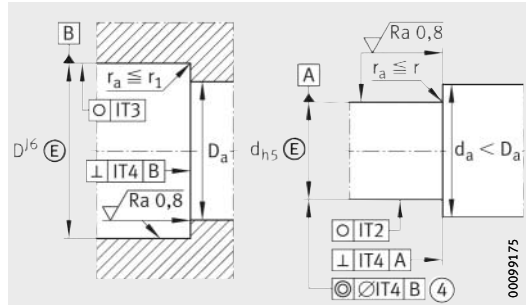

Design of housing and shaft (threaded spindle)

Mounting dimensions ¹⁾		Basic load ratings				Fatigue limit loads		Limiting speeds		Bearing frictional torque	Rigidity
		axial		radial		axial	radial	n _G oil	n _G grease		
D _a	d _a	dyn. C _a	stat. C _{0a}	dyn. C _r	stat. C _{0r}	C _{ua}	C _{ur}			min ⁻¹	min ⁻¹
max.	min.	N	N	N	N	N	N			Nm	N/μm
36	28	24 900	53 000	13 000	17 500	7 300	2 600	8 500	2 200	0,35	1 400
36	22	24 900	53 000	13 000	17 500	7 300	2 600	8 500	2 200	0,35	1 400
39	28	26 000	57 000	14 000	19 900	7 900	2 950	7 800	2 100	0,4	1 600
39	26	26 000	57 000	14 000	19 900	7 900	2 950	7 800	2 100	0,4	1 600
43	33	33 500	76 000	14 900	22 400	6 300	3 350	7 000	2 000	0,5	1 800
43	28	33 500	76 000	14 900	22 400	6 300	3 350	7 000	2 000	0,5	1 800
48	39	35 500	86 000	22 600	36 000	7 100	5 100	6 000	1 900	0,55	1 900
48	34	35 500	86 000	22 600	36 000	7 100	5 100	6 000	1 900	0,55	1 900
53	44	39 000	101 000	24 300	41 500	8 400	5 900	5 500	1 800	0,65	2 200
53	38	39 000	101 000	24 300	41 500	8 400	5 900	5 500	1 800	0,65	2 200

Dimension table (continued) · Dimensions in mm

Designation	Tilting rigidity	Mass moment of inertia ²⁾	Axial runout ²⁾	Recommended INA precision locknut ³⁾			Required locknut force ⁴⁾	Rotary shaft seal to DIN 3760; to be ordered separately
				For radial locking	For axial locking	Tightening torque ⁵⁾		
	c _{kL}	M _m	μm			M _A	axial	
	Nm/mrad	kg · cm ²				Nm	N	
ZARN1545-TV	110	0,24	1	ZMA15/33	AM15	10	6 506	–
ZARN1545-L-TV	110	0,274	1	ZMA15/33	AM15	10	6 506	24×35×7
ZARN1747-TV	160	0,373	1	ZM17	AM17	12	7 078	–
ZARN1747-L-TV	160	0,464	1	ZM17	AM17	12	7 078	28×40×7
ZARN2052-TV	230	0,615	1	ZMA20/38	AM20	18	8 972	–
ZARN2052-L-TV	230	0,683	1	ZMA20/38	AM20	18	8 972	30×42×7
ZARN2557-TV	350	0,989	1	ZMA25/45	AM25	25	9 745	–
ZARN2557-L-TV	350	1,15	1	ZMA25/45	AM25	25	9 745	36×47×7
ZARN3062-TV	520	1,46	1	ZMA30/52	AM30	32	10 662	–
ZARN3062-L-TV	520	1,7	1	ZMA30/52	AM30	32	10 662	40×52×7

Needle roller/axial cylindrical roller bearings

Light series
Without fixing holes

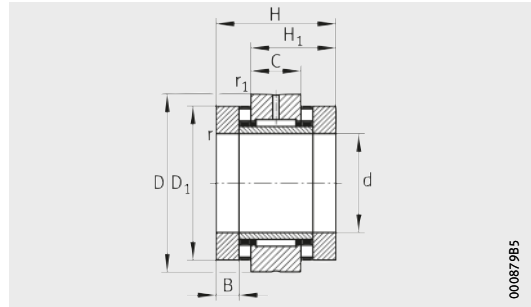

ZARN

000879B5

Dimension table (continued) · Dimensions in mm

Designation	Mass m ≈ kg	Dimensions														
		d	D	H	H ₁	H ₂	H ₃	C	D ₁	D ₂	D ₃	B	B ₁	B ₂	r	r ₁
															min.	min.
ZARN3570-TV	0,8	35	70	54	37	–	–	20	60	–	–	11	–	–	0,3	0,6
ZARN3570-L-TV	0,93	35	70	–	–	70	53	20	60	45	58	11	27	13	0,3	0,6
ZARN4075-TV	0,9	40	75	54	37	–	–	20	65	–	–	11	–	–	0,3	0,6
ZARN4075-L-TV	1	40	75	–	–	70	53	20	65	50	63	11	27	14	0,3	0,6
ZARN4580-TV	1,12	45	80	60	42,5	–	–	25	70	–	–	11,5	–	–	0,3	0,6
ZARN4580-L-TV	1,27	45	80	–	–	75	57,5	25	70	56	68	11,5	26,5	13	0,3	0,6
ZARN5090-TV	1,43	50	90	60	42,5	–	–	25	78	–	–	11,5	–	–	0,3	0,6
ZARN5090-L-TV	1,78	50	90	–	–	78	60,5	25	78	60	78	11,5	29,5	14	0,3	0,6

④ Only valid in assembled condition.

- 1) If rotary shaft seals are used, the outside diameter of the sealing ring must be taken into consideration.
- 2) Based on rotating inner ring.
- 3) The recommended INA precision locknuts are not included in the scope of delivery and must be ordered separately.
- 4) The required axial locknut force must be observed when using other locknuts.
- 5) Only valid in conjunction with INA precision locknuts.
Note the guidelines on locating/locating bearing arrangements, see page 54.

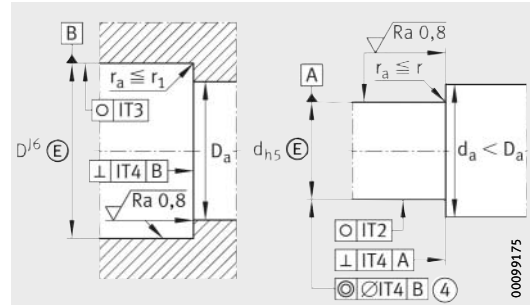
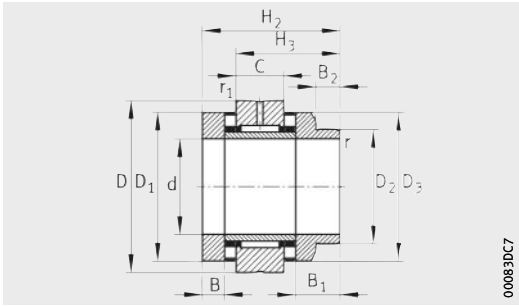

ZARN..L

Design of housing and shaft (threaded spindle)

Mounting dimensions ¹⁾		Basic load ratings				Fatigue limit loads		Limiting speeds		Bearing frictional torque	Rigidity
		axial		radial		axial	radial				
D _a	d _a	dyn. C _a	stat. C _{0a}	dyn. C _r	stat. C _{0r}	C _{ua}	C _{ur}	n _G oil	n _G grease	M _R	c _{aL}
max.	min.	N	N	N	N	N	N	min ⁻¹	min ⁻¹	Nm	N/μm
61	50	56 000	148 000	26 000	47 000	12 800	6 700	4 800	1 700	0,9	2 600
61	43	56 000	148 000	26 000	47 000	12 800	6 700	4 800	1 700	0,9	2 600
66	55	59 000	163 000	27 500	53 000	14 100	7 500	4 400	1 600	1	2 800
66	48	59 000	163 000	27 500	53 000	14 100	7 500	4 400	1 600	1	2 800
71	60	61 000	177 000	38 000	74 000	15 400	10 200	4 000	1 500	1,2	3 000
71	54	61 000	177 000	38 000	74 000	15 400	10 200	4 000	1 500	1,2	3 000
79	67	90 000	300 000	40 000	82 000	27 500	11 300	3 600	1 200	2,2	4 800
79	58	90 000	300 000	40 000	82 000	27 500	11 300	3 600	1 200	2,2	4 800

Dimension table (continued) · Dimensions in mm

Designation	Tilting rigidity	Mass moment of inertia ²⁾	Axial runout ²⁾	Recommended INA precision locknut ³⁾			Required locknut force ⁴⁾	Rotary shaft seal to DIN 3760; to be ordered separately
				For radial locking	For axial locking	Tightening torque ⁵⁾		
	c _{kL}	M _m	μm			M _A	axial	
	Nm/mrad	kg · cm ²				Nm	N	
ZARN3570-TV	740	2,8	1	ZMA35/58	AM35/58	40	12 143	–
ZARN3570-L-TV	740	3,21	1	ZMA35/58	AM35/58	40	12 143	45×60×8
ZARN4075-TV	1 030	3,78	1	ZMA40/62	AM40	55	14 240	–
ZARN4075-L-TV	1 030	4,35	1	ZMA40/62	AM40	55	14 240	50×65×8
ZARN4580-TV	1 340	5,33	1	ZMA45/68	AM45	65	15 112	–
ZARN4580-L-TV	1 340	6,03	1	ZMA45/68	AM45	65	15 112	56×70×8
ZARN5090-TV	2 470	8,42	1	ZMA50/75	AM50	85	18 410	–
ZARN5090-L-TV	2 470	10,46	1	ZMA50/75	AM50	85	18 410	60×80×8



Needle roller/axial cylindrical roller bearings

Heavy series
Without fixing holes

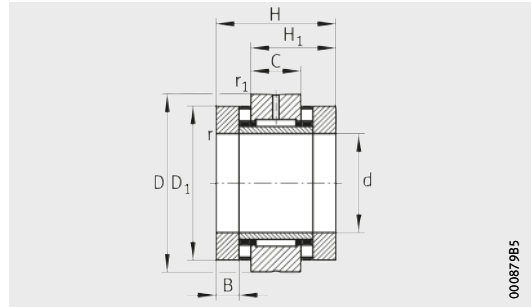

ZARN

00087985

Dimension table - Dimensions in mm

Designation	Mass m ≈ kg	Dimensions														
		d	D	H	H ₁	H ₂	H ₃	C	D ₁	D ₂	D ₃	B	B ₁	B ₂	r	r ₁
															min.	min.
ZARN2062-TV	0,87	20	62	60	40	–	–	20	52	–	–	12,5	–	–	0,3	0,6
ZARN2062-L-TV	0,99	20	62	–	–	75	55	20	52	40	50	12,5	27,5	13	0,3	0,6
ZARN2572-TV	1,17	25	72	60	40	–	–	20	62	–	–	12,5	–	–	0,3	0,6
ZARN2572-L-TV	1,32	25	72	–	–	75	55	20	62	48	60	12,5	27,5	13	0,3	0,6
ZARN3080-TV	1,5	30	80	66	43	–	–	20	68	–	–	14	–	–	0,3	0,6
ZARN3080-L-TV	1,7	30	80	–	–	82	59	20	68	52	66	14	30	13	0,3	0,6
ZARN3585-TV	1,65	35	85	66	43	–	–	20	73	–	–	14	–	–	0,3	0,6
ZARN3585-L-TV	1,8	35	85	–	–	82	59	20	73	60	73	14	30	13	0,3	0,6

④ Only valid in assembled condition.

- 1) If rotary shaft seals are used, the outside diameter of the sealing ring must be taken into consideration.
- 2) Based on rotating inner ring.
- 3) The recommended INA precision locknuts are not included in the scope of delivery and must be ordered separately.
- 4) The required axial locknut force must be observed when using other locknuts.
- 5) Only valid in conjunction with INA precision locknuts.
Note the guidelines on locating/locating bearing arrangements, see page 54.

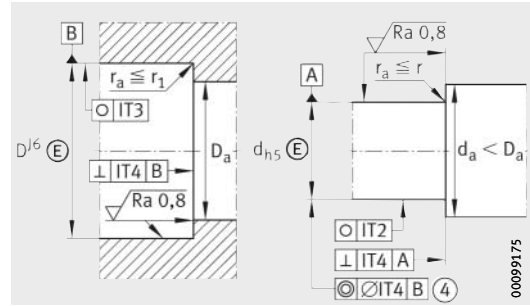
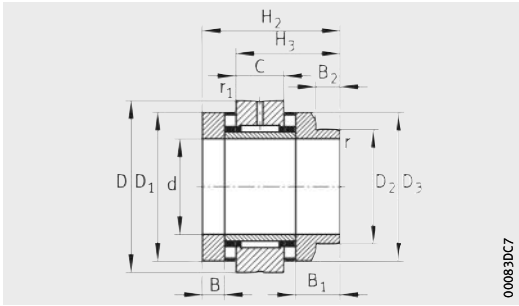

ZARN..L

Design of housing and shaft (threaded spindle)

Mounting dimensions ¹⁾		Basic load ratings				Fatigue limit loads		Limiting speeds		Bearing frictional torque	Rigidity
		axial		radial		axial	radial				
D _a	d _a	dyn. C _a	stat. C _{0a}	dyn. C _r	stat. C _{0r}	C _{ua}	C _{ur}	n _G oil	n _G grease	M _R	axial C _{aL}
max.	min.	N	N	N	N	N	N	min ⁻¹	min ⁻¹	Nm	N/μm
53	38	64 000	141 000	22 600	36 000	12 900	5 100	6 000	1 500	1,3	2 300
53	38	64 000	141 000	22 600	36 000	12 900	5 100	6 000	1 500	1,3	2 300
63	45	80 000	199 000	24 300	41 500	18 300	5 900	4 900	1 400	1,6	3 000
63	45	80 000	199 000	24 300	41 500	18 300	5 900	4 900	1 400	1,6	3 000
69	52	107 000	265 000	26 000	47 000	22 500	6 700	4 400	1 300	2,1	3 300
69	50	107 000	265 000	26 000	47 000	22 500	6 700	4 400	1 300	2,1	3 300
74	60	105 000	265 000	27 500	53 000	22 500	7 500	4 000	1 250	2,3	3 500
74	58	105 000	265 000	27 500	53 000	22 500	7 500	4 000	1 250	2,3	3 500

Dimension table (continued) · Dimensions in mm

Designation	Tilting rigidity	Mass moment of inertia ²⁾	Axial runout ²⁾	Recommended INA precision locknut ³⁾			Required locknut force ⁴⁾	Rotary shaft seal to DIN 3760; to be ordered separately
				For radial locking	For axial locking	Tightening torque ⁵⁾		
	c _{kL}	M _m	μm			M _A	axial	
	Nm/mrad	kg · cm ²				Nm	N	
ZARN2062-TV	400	1,98	1	ZMA20/52	AM20	38	17 623	–
ZARN2062-L-TV	400	2,27	1	ZMA20/52	AM20	38	17 623	40×52×7
ZARN2572-TV	800	3,88	1	ZMA25/58	AM25	55	20 790	–
ZARN2572-L-TV	800	4,51	1	ZMA25/58	AM25	55	20 790	48×62×8
ZARN3080-TV	1 100	6,53	1	ZMA30/65	AM30	75	24 287	–
ZARN3080-L-TV	1 100	7,43	1	ZMA30/65	AM30	75	24 287	52×68×8
ZARN3585-TV	1 300	8,47	1	ZMA35/70	AM35	100	27 480	–
ZARN3585-L-TV	1 300	10,4	1	ZMA35/70	AM35	100	27 480	60×75×8



Needle roller/axial cylindrical roller bearings

Heavy series
Without fixing holes

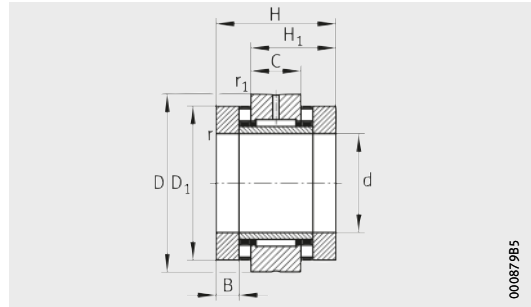

ZARN

000879B5

Dimension table (continued) · Dimensions in mm

Designation	Mass m ≈ kg	Dimensions															
		d	D	H	H ₁	H ₂	H ₃	C	D ₁	D ₂	D ₃	B	B ₁	B ₂	r	r ₁	
																min.	min.
ZARN4090-TV	2,09	40	90	75	50	–	–	25	78	–	–	16	–	–	0,3	0,6	
ZARN4090-L-TV	2,39	40	90	–	–	93	68	25	78	60	78	16	34	14	0,3	0,6	
ZARN45105-TV	3,02	45	105	82	53,5	–	–	25	90	–	–	17,5	–	–	0,3	0,6	
ZARN45105-L-TV	3,42	45	105	–	–	103	74,5	25	90	70	88	17,5	38,5	18	0,3	0,6	
ZARN50110-TV	3,3	50	110	82	53,5	–	–	25	95	–	–	17,5	–	–	0,3	0,6	
ZARN50110-L-TV	3,75	50	110	–	–	103	74,5	25	95	75	93	17,5	38,5	18	0,3	0,6	
ZARN55115-TV	3,5	55	115	82	53,5	–	–	25	100	–	–	17,5	–	–	0,3	0,6	
ZARN55115-L-TV	4	55	115	–	–	103	74,5	25	100	80	98	17,5	38,5	18	0,3	0,6	

④ Only valid in assembled condition.

- 1) If rotary shaft seals are used, the outside diameter of the sealing ring must be taken into consideration.
- 2) Based on rotating inner ring.
- 3) The recommended INA precision locknuts are not included in the scope of delivery and must be ordered separately.
- 4) The required axial locknut force must be observed when using other locknuts.
- 5) Only valid in conjunction with INA precision locknuts.
Note the guidelines on locating/locating bearing arrangements, see page 54.

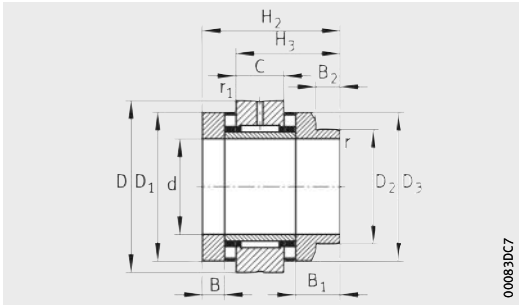

ZARN..L

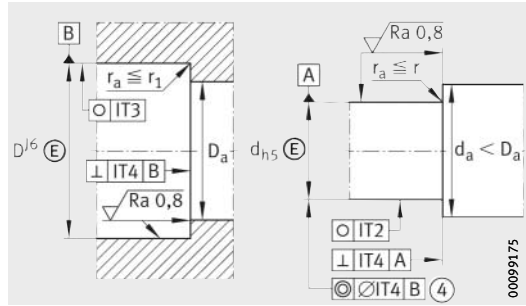

Design of housing and shaft (threaded spindle)

Mounting dimensions ¹⁾		Basic load ratings				Fatigue limit loads		Limiting speeds		Bearing frictional torque	Rigidity
		axial		radial		axial	radial	n _G oil	n _G grease		
D _a	d _a	dyn. C _a	stat. C _{0a}	dyn. C _r	stat. C _{0r}	C _{ua}	C _{ur}				
max.	min.	N	N	N	N	N	N	min ⁻¹	min ⁻¹	Nm	N/μm
79	65	117 000	315 000	38 000	74 000	26 500	10 200	3 700	1 200	2,5	3 800
79	58	117 000	315 000	38 000	74 000	26 500	10 200	3 700	1 200	2,5	3 800
91	70	154 000	405 000	40 000	82 000	36 500	11 300	3 300	1 150	3,5	4 000
91	68	154 000	405 000	40 000	82 000	36 500	11 300	3 300	1 150	3,5	4 000
96	75	172 000	480 000	42 000	90 000	43 500	12 400	3 100	1 100	3,8	4 600
96	73	172 000	480 000	42 000	90 000	43 500	12 400	3 100	1 100	3,8	4 600
101	85	177 000	500 000	44 000	98 000	46 000	13 500	2 900	1 000	4	4 900
101	78	177 000	500 000	44 000	98 000	46 000	13 500	2 900	1 000	4	4 900

Dimension table (continued) · Dimensions in mm

Designation	Tilting rigidity	Mass moment of inertia ²⁾	Axial runout ²⁾	Recommended INA precision locknut ³⁾			Required locknut force ⁴⁾	Rotary shaft seal to DIN 3760; to be ordered separately
				For radial locking	For axial locking	Tightening torque ⁵⁾		
	c _{kL}	M _m	μm			M _A	axial	
	Nm/mrad	kg · cm ²				Nm	N	
ZARN4090-TV	1 800	13,3	1	ZMA40/75	AM40	120	29 834	–
ZARN4090-L-TV	1 800	15,5	1	ZMA40/75	AM40	120	29 834	60×80×8
ZARN45105-TV	2 100	23,7	1	ZMA45/85	AM45	150	33 549	–
ZARN45105-L-TV	2 100	28,1	1	ZMA45/85	AM45	150	33 549	70×90×10
ZARN50110-TV	2 900	29,8	1	ZMA50/92	AM50	180	36 224	–
ZARN50110-L-TV	2 900	35,3	1	ZMA50/92	AM50	180	36 224	75×95×10
ZARN55115-TV	3 600	36,1	1	ZMA55/98	AM55	220	39 807	–
ZARN55115-L-TV	3 600	43	1	ZMA55/98	AM55	220	39 807	80×100×10



Needle roller/axial cylindrical roller bearings

Heavy series
Without fixing holes

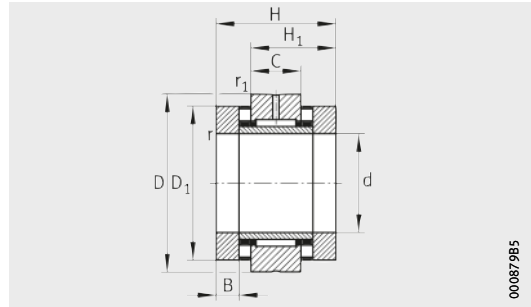

ZARN

00087985

Dimension table (continued) · Dimensions in mm

Designation	Mass m ≈ kg	Dimensions														
		d	D	H	H ₁	H ₂	H ₃	C	D ₁	D ₂	D ₃	B	B ₁	B ₂	r	r ₁
															min.	min.
ZARN60120-TV	3,7	60	120	82	53,5	–	–	25	105	–	–	17,5	–	–	0,3	0,6
ZARN60120-L-TV	4,85	60	120	–	–	103	74,5	25	105	90	105	17,5	38,5	18	0,3	0,6
ZARN65125-TV	4	65	125	82	53,5	–	–	25	110	–	–	17,5	–	–	0,3	0,6
ZARN65125-L-TV	4,6	65	125	–	–	103	74,5	25	110	90	108	17,5	38,5	18	0,3	0,6
ZARN70130-TV	4,1	70	130	82	53,5	–	–	25	115	–	–	17,5	–	–	0,3	0,6
ZARN70130-L-TV	4,85	70	130	–	–	103	74,5	25	115	100	115	17,5	38,5	18	0,3	0,6
ZARN75155-TV	7,9	75	155	100	65	–	–	30	135	–	–	21	–	–	0,3	1
ZARN75155-L-TV	9,1	75	155	–	–	125	90	30	135	115	135	21	46	20	0,3	1
ZARN90180-TV	11,8	90	180	110	72,5	–	–	35	160	–	–	22,5	–	–	0,3	1
ZARN90180-L-TV	13,2	90	180	–	–	135	97,5	35	160	130	158	22,5	47,5	18	0,3	1

④ Only valid in assembled condition.

- 1) If rotary shaft seals are used, the outside diameter of the sealing ring must be taken into consideration.
- 2) Based on rotating inner ring.
- 3) The recommended INA precision locknuts are not included in the scope of delivery and must be ordered separately.
- 4) The required axial locknut force must be observed when using other locknuts.
- 5) Only valid in conjunction with INA precision locknuts.
Note the guidelines on locating/locating bearing arrangements, see page 54.

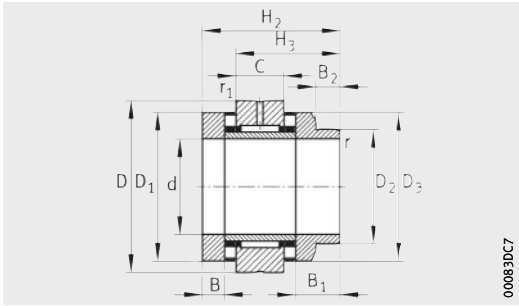

ZARN..L

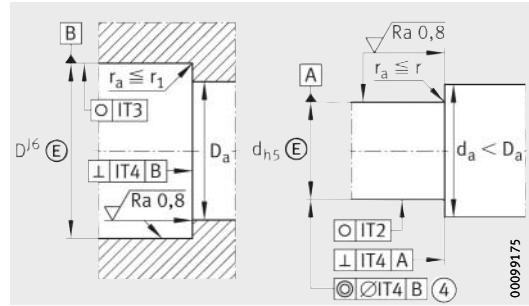

Design of housing and shaft (threaded spindle)

Mounting dimensions ¹⁾		Basic load ratings				Fatigue limit loads		Limiting speeds		Bearing frictional torque	Rigidity axial
		axial		radial		axial	radial	n _G oil	n _G grease		
D _a	d _a	dyn. C _a	stat. C _{0a}	dyn. C _r	stat. C _{0r}	C _{ua}	C _{ur}			min ⁻¹	min ⁻¹
max.	min.	N	N	N	N	N	N			Nm	N/μm
106	90	187 000	550 000	44 500	92 000	50 000	12 600	2 700	950	4,2	5 300
106	88	187 000	550 000	44 500	92 000	50 000	12 600	2 700	950	4,2	5 300
111	97	172 000	500 000	54 000	104 000	46 000	14 600	2 600	900	4	4 800
111	88	172 000	500 000	54 000	104 000	46 000	14 600	2 600	900	4	4 800
116	100	201 000	630 000	56 000	119 000	57 000	15 800	2 400	800	4,8	5 800
116	98	201 000	630 000	56 000	119 000	57 000	15 800	2 400	800	4,8	5 800
136	113	290 000	890 000	72 000	132 000	84 000	18 800	2 100	700	8	6 600
136	110	290 000	890 000	72 000	132 000	84 000	18 800	2 100	700	8	6 600
161	130	325 000	1 030 000	98 000	210 000	93 000	28 500	1 800	700	10,5	7 700
161	125	325 000	1 030 000	98 000	210 000	93 000	28 500	1 800	700	10,5	7 700

Dimension table (continued) · Dimensions in mm

Designation	Tilting rigidity	Mass moment of inertia ²⁾	Axial runout ²⁾	Recommended INA precision locknut ³⁾			Required locknut force ⁴⁾	Rotary shaft seal to DIN 3760; to be ordered separately
				For radial locking	For axial locking	Tightening torque ⁵⁾		
	c _{kL}	M _m	μm			M _A	axial	
	Nm/mrad	kg · cm ²				Nm	N	
ZARN60120-TV	4 300	43,8	1	ZMA60/98	AM60	250	41 144	–
ZARN60120-L-TV	4 300	54,5	1	ZMA60/98	AM60	250	41 144	90×110×12
ZARN65125-TV	4 000	51	1	ZMA65/105	AM65	270	40 652	–
ZARN65125-L-TV	4 000	60,1	1	ZMA65/105	AM65	270	40 652	90×110×12
ZARN70130-TV	6 000	62,2	1	ZMA70/110	AM70	330	46 786	–
ZARN70130-L-TV	6 000	77,3	1	ZMA70/110	AM70	330	46 786	100×120×12
ZARN75155-TV	8 500	149	2	ZMA75/125	AM75	580	72 971	–
ZARN75155-L-TV	8 500	188	2	ZMA75/125	AM75	580	72 971	115×140×12
ZARN90180-TV	14 500	312	2	ZMA90/155	AM90	960	100 669	–
ZARN90180-L-TV	14 500	372	2	ZMA90/155	AM90	960	100 669	130×160×12



FAG



Accessories

Seal carrier assemblies

Precision locknuts

Sockets

BEARINX-online Easy BallScrew

Accessories

	Page
Product overview	Seal carrier assemblies, precision locknuts, sockets, calculation of screw drive bearing arrangements 136
Features	Seal carrier assemblies..... 137
	Operating temperature 137
	Limiting speeds 138
	Precision locknuts 139
Design and safety guidelines	Breakaway torque..... 141
	Ultimate axial load 141
	Mounting guidelines..... 141
Accuracy 145
Dimension tables	Seal carrier assemblies DRS..... 146
	Precision locknuts AM, for axial locking 148
	Precision locknuts ZM, ZMA, for radial locking..... 149
	Sockets 151
Calculation of screw drive bearing arrangements	BEARINX-online 154
	Module Easy BallScrew..... 154
	User-friendly interface 155
	Data interchange with Schaeffler 156



Product overview Accessories

Seal carrier assemblies

DRS

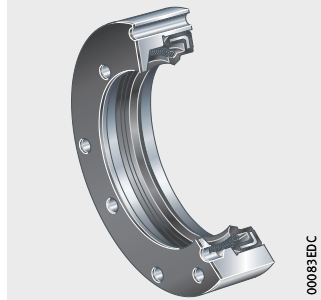

Precision locknuts

For axial locking
For radial locking

AM

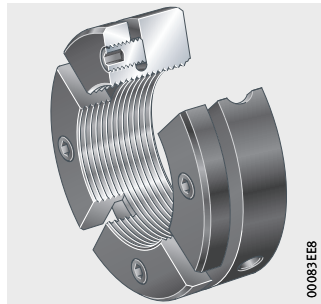

ZM, ZMA

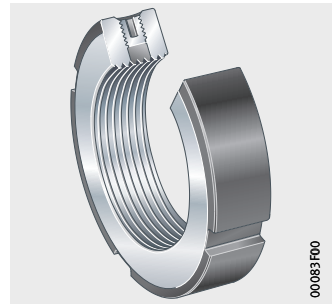

Sockets

AMS

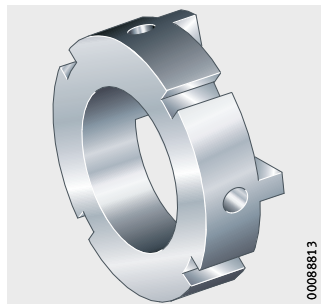

LOCKNUT-SOCKET-KM

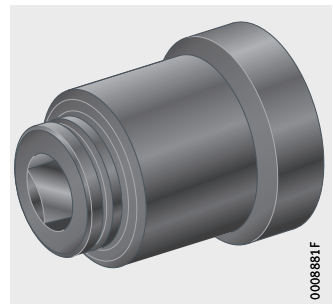

Calculation of screw drive bearing arrangements

BEARINX-online Easy BallScrew

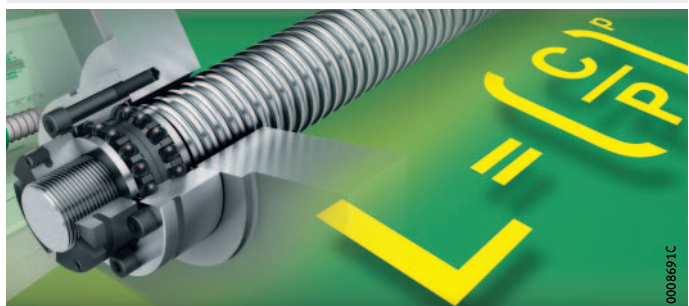

Accessories

Features

Seal carrier assemblies

Seal carrier assemblies DRS are screw mounted to the outer ring of needle roller/axial cylindrical roller bearings ZARF(L) and precisely centred in this position, *Figure 1*. They seal the bearings against outside influences.

The sealing elements are supplied as a complete set of individual parts and comprise:

- a seal flange
- a rotary shaft seal to DIN 3760, with an elastomer part made from NBR
- a gasket
- hexagonal socket head screws for fixing the carrier to the central washer of the bearing.

DRS
ZMA
ZARF.-L

- ① Seal carrier assembly DRS
- ② Precision locknut ZM or ZMA
- ③ Rotary shaft seal DIN 3760

Figure 1
Needle roller/axial
cylindrical roller bearing
with seal carrier assembly

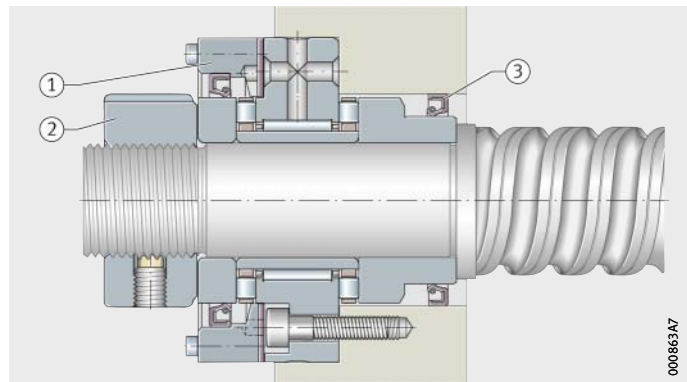

Operating temperature

Seal carrier assemblies are suitable for operating temperatures from -30 °C to $+120\text{ °C}$, restricted by the seal material.



Accessories

Limiting speeds

The limiting speeds for rotary shaft seals made from NBR conform to DIN 3760, *Figure 2*. These may be lower than the limiting speeds of the bearings. For the bearing arrangement, the lower of the two limiting speeds is always the decisive factor.

v = circumferential velocity
 d = seal lip diameter
of seal carrier assembly DRS
 n = speed

Figure 2
Limiting speeds
under pressure-free operation
for rotary shaft seals

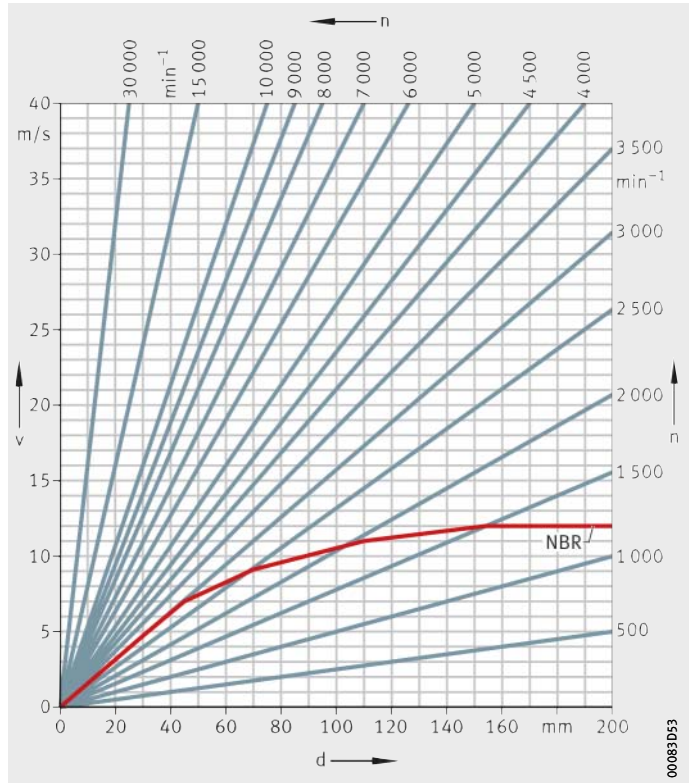

Precision locknuts

Precision locknuts are used where high axial forces must be supported and high axial runout accuracy and rigidity are required, *Figure 3* and *Figure 4*, page 140.

The thread and the axial face of the locknut in contact with the rolling bearing are produced in a single clamping operation. This allows very high axial runout accuracy to be achieved.

The available precision locknuts AM, ZM and ZMA can be used several times if handled correctly.

Axial locking by segments

Precision locknuts AM with axial locking are divided into several segments for applying the locking forces. When the hexagonal socket grub screws are tightened, the segments are elastically deformed. As a result, the thread flanks of the segments are pressed against the flanks of the shaft thread and give a high frictional force that acts to prevent loosening of the nut. The axial runout of the nut is not affected by this method of locking.

AM
ZKLF..-2RS

① Precision locknut AM

Figure 3
Mounting clearance
with locknut AM for axial locking

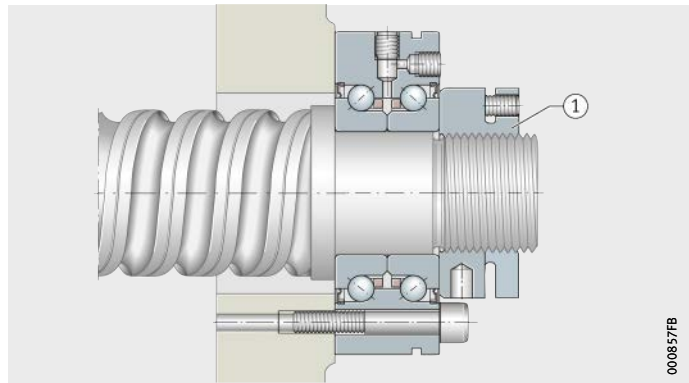

Accessories

Locking by radial locking pegs

Precision locknuts ZM and ZMA are secured against rotation by means of two radially acting locking pegs, *Figure 4*. ZMA is the heavy series.

The locking pegs are manufactured together with the internal thread of the locknut. They mesh like comb teeth in the thread of the shaft without affecting the axial runout or damaging the thread.

The locking pegs are secured by grub screws with a hexagonal socket arranged concentrically over the locking pegs.

- DRS**
ZMA
ZARF..L
- ① Precision locknut ZM or ZMA
 - ② Locking peg
 - ③ Grub screw

Figure 4
Mounting clearance
with locknut ZM, ZMA
for radial locking

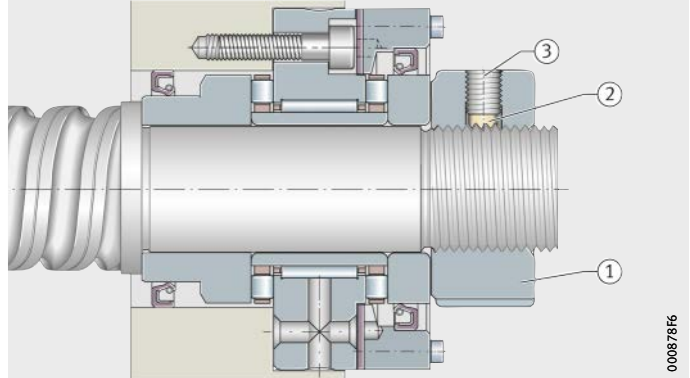

Design and safety guidelines

Shaft threads for the precision locknuts must be precision machined, see table.

Recommended shaft thread

Shaft thread to DIN 13-21 to DIN 13-24	
Tolerance class	
Medium	Fine
6g	4h



The journal thread must support the locknut over its whole width.

Breakaway torque

The breakaway torques M_L given in the dimension tables are based on a locknut tightened against a rigid shaft shoulder to the reference tightening torque M_{AL} and secured.

Ultimate axial load

The axial ultimate loads F_{aB} are valid for a journal thread of tolerance class 6g or better and a minimum strength of 700 N/mm^2 .

For dynamic loading, the permissible value can be taken as 75% of the ultimate load F_{aB} .

Mounting guidelines

The characteristics of the bearings are only valid when used in combination with INA precision locknuts and the associated tightening torques given in the dimension tables.



Locknuts must be fully screwed onto the shaft thread.

Bearings and precision locknuts should only be mounted and dismantled in accordance with the Mounting and Maintenance Manual TPI 100.

Further information

- TPI 100, Bearings for Screw Drives, Mounting and Maintenance Manual
- Download and ordering: <http://medien.schaeffler.de>.



Accessories

Precision locknuts for axial locking

Precision locknuts AM for axial locking can be tightened using a hook wrench of type B to DIN 1810 that engages in four, six or eight holes around the circumference, *Figure 5*.

The grub screws are then tightened in a crosswise sequence to the specified tightening torque M_A using an Allen key. Dismounting is carried out by uniformly loosening the grub screws of all segments in order to prevent a single segment being left tensioned.



Tightening by means of just one segment is not permissible. For tightening, a socket AMS can be used that ensures uniform loading of all segments. The socket AMS must be ordered separately, see page 151.

For tightening using the socket AMS, a hook wrench of type B or type A to DIN 1810 or an FAG socket can be used, see page 144.

If precision locknuts AM are fitted using the socket AMS, a maximum of twice the tightening torque of the bearing according to the dimension table is permissible.

Segments can be axially deformed if the grub screws are not tightened uniformly in a crosswise sequence or the locknut AM is not fully screwed onto the shaft thread. The specified tightening torque M_A in the dimension table must be observed.

- ① Socket AMS
- ② Hook wrench type A to DIN 1810
- ③ Hook wrench type B to DIN 1810
- ④ FAG socket LOCKNUT-SOCKET-KM
- ⑤ Torque wrench

Figure 5
Mounting tools
for precision locknuts AM

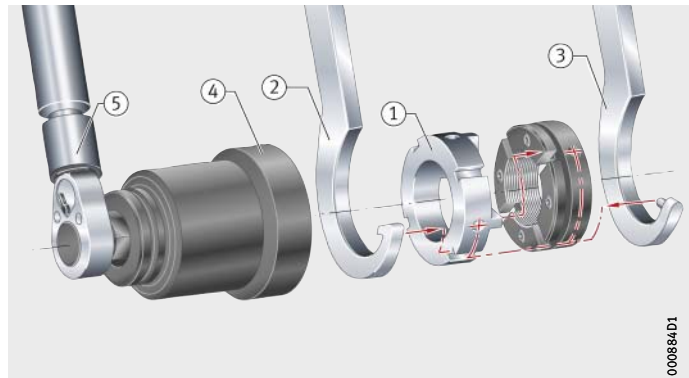

Precision locknuts for radial locking

For tightening of locknuts ZM and ZMA, a hook wrench to DIN 1810A that engages in one of the four slots around the circumference or an FAG socket can be used, *Figure 6*.

The two grub screws are then tightened alternately to the specified tightening torque M_A using an Allen key; for M_A , see dimension tables for the bearings.

For dismantling, the two grub screws are first loosened and the locking pegs loosened by light impacts with a plastic hammer on the outside surface of the locknut (in the vicinity of the screw holes).

The locknut can then be easily unscrewed without damaging the journal thread.

- ① Hook wrench type A to DIN 1810
- ② FAG socket LOCKNUT-SOCKET-KM
- ③ Torque wrench

Figure 6
Mounting tools
for precision locknuts ZM

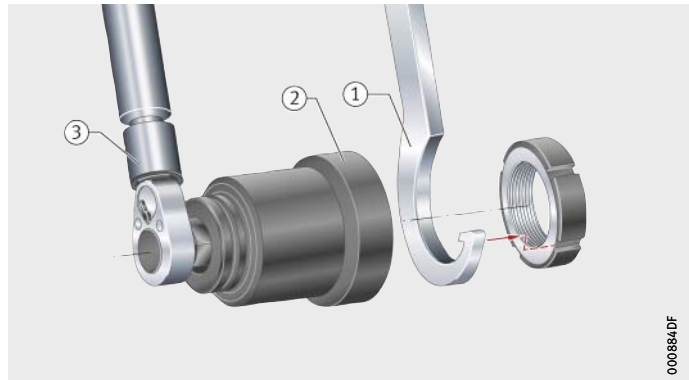

Accessories

FAG sockets

For simple tightening and loosening of precision locknuts ZM on shafts, the sockets LOCKNUT-SOCKET-KM, *Figure 7* are suitable. In combination with the socket AMS, this socket is also suitable for precision locknuts AM. They require less space on the circumference of the locknut than hook wrenches and allow the use of torque wrenches.

For increased reliability, FAG sockets should be secured using a locking pin and rubber ring. They therefore have a hole for the locking pin and a groove for the rubber ring. The locking pin and rubber ring are included in the scope of delivery.



Figure 7
FAG socket
for precision locknuts ZM
and sockets AMS

Accuracy Accuracy of precision locknuts: see table.

Axial runout

Axial runout of axial face to thread ¹⁾	Metric thread in accordance with DIN 13-21 to DIN 13-24 Tolerance class
μm	Fine
5	5H

¹⁾ The axial face and thread are machined in a single clamping operation, in order to achieve very high accuracy. Before measurement, the precision locknut is clamped against a rigid shoulder on a threaded mandrel to a defined tightening torque. The grub screws remain loosened.



Seal carrier assemblies

For ZARF, light series

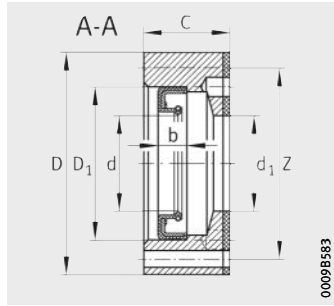

DRS¹⁾

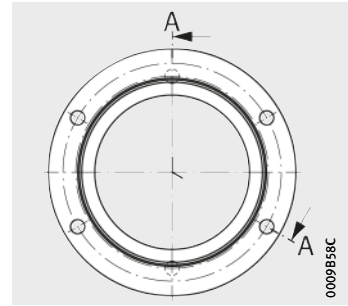

Hole pattern
DRS1560, DRS1762

Dimension table - Dimensions in mm

Designation	Mass m ≈ kg	Dimensions				Rotary shaft seal				Matching bearing
		D	C	d ₁	Z	d	D ₁	b	Socket head screws to DIN EN ISO 4762 4 pieces each	
DRS1560	0,16	60	14	35	52,4	35	45	7	M3×20	ZARF1560(-L)-TV
DRS1762	0,18	62	15,5	38	54,4	38	47	7	M3×25	ZARF1762(-L)-TV
DRS2068	0,2	68	17	42	60,4	42	55	8	M3×25	ZARF2068(-L)-TV
DRS2575	0,22	75	17	47	67,4	47	62	6	M3×25	ZARF2575(-L)-TV
DRS3080	0,26	80	17	52	73,4	52	68	8	M3×25	ZARF3080(-L)-TV
DRS3590	0,38	90	19	60	80	60	72	8	M4×25	ZARF3590(-L)-TV
DRS40100	0,47	100	19	65	90	65	80	8	M4×30	ZARF40100(-L)-TV
DRS45105	0,53	105	20	70	95	70	85	8	M4×30	ZARF45105(-L)-TV
DRS50115	0,54	115	20	78	106	78	100	10	M3×30	ZARF50115(-L)-TV

1) The seal carrier assembly is supplied as a sealing set in individual parts comprising:

- a seal flange
- a rotary shaft seal
- a gasket
- socket head screws.

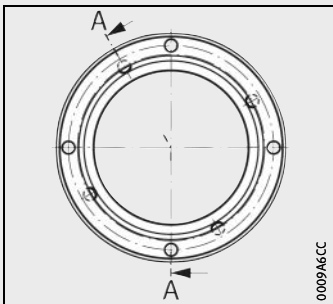

Hole pattern DRS3080, DRS3590,
DRS50115

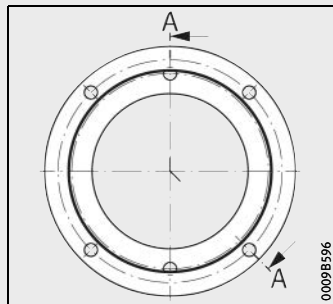

Hole pattern DRS2068, DRS2575,
DRS40100, DRS45105

Seal carrier assemblies

For ZARF, heavy series

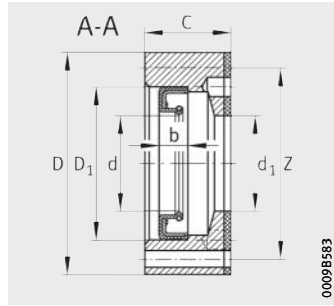

DRS¹⁾

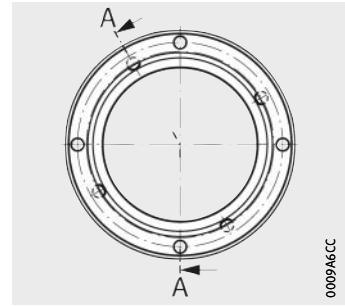

Hole pattern

Dimension table · Dimensions in mm

Designation	Mass m ≈ kg	Dimensions				Rotary shaft seal				Matching bearing
		D	C	d ₁	Z	d	D ₁	b	Socket head screws to DIN EN ISO 4762 4 pieces each	
DRS2080	0,3	80	22	52	73,4	52	68	8	M3×30	ZARF2080(-L)-TV
DRS2590	0,38	90	22	62	81	62	75	10	M3×30	ZARF2590(-L)-TV
DRS30105	0,67	105	25	68	95	68	85	10	M4×35	ZARF30105(-L)-TV
DRS35110	0,6	110	25	73	101	73	95	10	M3×30	ZARF35110(-L)-TV
DRS40115	0,7	115	27,5	78	106	78	100	10	M3×35	ZARF40115(-L)-TV
DRS45130	1,1	130	31	90	120	90	110	12	M4×40	ZARF45130(-L)-TV
DRS50140	1,4	140	30	95	127,5	95	115	13	M5×40	ZARF50140(-L)-TV
DRS55145	1,42	145	30	100	132,5	100	120	12	M5×40	ZARF55145(-L)-TV
DRS60150	1,42	150	30	105	137,5	105	125	12	M5×40	ZARF60150(-L)-TV
DRS65155	1,43	155	30	110	142,5	110	130	12	M5×40	ZARF65155(-L)-TV
DRS70160	1,5	160	30	115	147,5	115	135	13	M5×40	ZARF70160(-L)-TV
DRS75185	2,4	185	36	135	172,5	135	160	15	M5×50	ZARF75185(-L)-TV
DRS90210	2,7	210	38	160	194	160	180	15	M5×50	ZARF90210(-L)-TV

1) The seal carrier assembly is supplied as a sealing set in individual parts comprising:

- a seal flange
- a rotary shaft seal
- a gasket
- socket head screws.



Precision locknuts

For axial locking

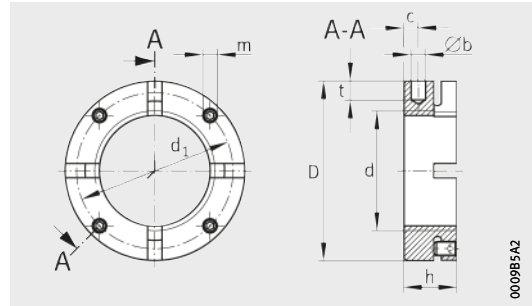

AM15 to AM40 with 4 segments
 AM45 to AM90 with 6 segments
 AM100 to AM130 with 8 segments

Dimension table - Dimensions in mm															
Designation	Mass m ≈ kg	Dimensions									Grub screw Tightening torque M_A Nm	Locknut ¹⁾			
		d	D	h	b H11	t	d_1	c	m	Axial rupture load F_{aB} N		Break-away torque M_L at M_{AL} Nm	Reference tightening torque Nm	Mass moment of inertia M_M kg · cm ²	
AM15	0,06	M15×1	30	18	4	5	24	5	M5	3	100 000	20	10	0,09	
AM17	0,07	M17×1	32	18	4	5	26	5	M5	3	120 000	25	15	0,11	
AM20	0,13	M20×1	38	18	4	6	31	5	M6	5	145 000	45	18	0,23	
AM25	0,16	M25×1,5	45	20	5	6	38	6	M6	5	205 000	60	25	0,49	
AM30	0,20	M30×1,5	52	20	5	7	45	6	M6	5	250 000	70	32	0,86	
AM30/65	0,50	M30×1,5	65	30	6	8	45	6	M6	5	400 000	70	32	2,8	
AM35/58	0,23	M35×1,5	58	20	5	7	51	6	M6	5	280 000	90	40	1,3	
AM35	0,33	M35×1,5	65	22	6	8	58	6	M6	5	330 000	100	40	2,4	
AM40	0,30	M40×1,5	65	22	6	8	58	6	M6	5	350 000	120	55	2,3	
AM40/85	0,75	M40×1,5	85	32	6	8	58	6	M6	5	570 000	120	55	7,6	
AM45	0,34	M45×1,5	70	22	6	8	63	6	M6	5	360 000	220	65	2,9	
AM50	0,43	M50×1,5	75	25	6	8	68	8	M6	5	450 000	280	85	4,3	
AM55	0,60	M55×2	85	26	6	8	75	8	M8	15	520 000	320	95	7,7	
AM60	0,65	M60×2	90	26	6	8	80	8	M8	15	550 000	365	100	9,4	
AM65	0,83	M65×2	100	26	8	10	88	8	M8	15	560 000	400	120	14,6	
AM70	0,79	M70×2	100	28	8	10	90	9	M8	15	650 000	450	130	14,7	
AM75	1,23	M75×2	115	30	8	10	102	10	M10	20	750 000	610	150	29	
AM80	0,93	M80×2	110	30	8	10	98	10	M10	20	670 000	770	160	21,3	
AM85	0,97	M85×2	115	30	8	10	102	10	M10	20	690 000	930	180	24,8	
AM90	1,53	M90×2	130	32	8	10	118	13	M10	20	900 000	1 100	200	48	
AM100	1,12	M100×2	130	30	8	10	118	10	M10	20	740 000	1 200	250	38	
AM110	1,22	M110×2	140	30	8	10	128	10	M10	20	770 000	1 300	250	48	
AM120	1,56	M120×2	155	30	8	10	142	10	M10	20	880 000	1 450	250	75	
AM130	1,67	M130×2	165	30	8	10	152	10	M10	20	900 000	1 600	250	92	

¹⁾ Attention!

If precision locknuts AM are fitted using the socket AMS, a maximum of twice the tightening torque of the bearing according to the dimension table is permissible.

Precision locknuts

For radial locking

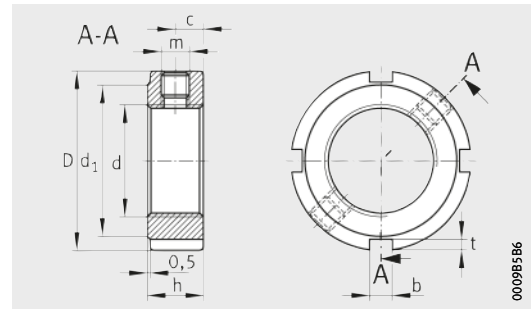

ZM, ZMA

Dimension table · Dimensions in mm														
Designation	Mass	Dimensions								Grub screw	Locknut			
		d	D	h	b	t	d ₁	c	m		Tightening torque	Axial rupture load	Break-away torque	Reference tightening torque
	m ≈ kg									M _A Nm	F _{aB} N	M _L at M _{AL} Nm		M _M kg · cm ²
ZM06	0,01	M6×0,5	16	8	3	2	11	4	M4	1	17 000	20	2	0,004
ZM08 ¹⁾	0,01	M8×0,75	16	8	3	2	11	4	M4	1	23 000	25	4	0,004
ZM10 ¹⁾	0,01	M10×1	18	8	3	2	14	4	M4	1	31 000	30	6	0,006
ZM12	0,015	M12×1	22	8	3	2	18	4	M4	1	38 000	30	8	0,013
ZM15	0,018	M15×1	25	8	3	2	21	4	M4	1	50 000	30	10	0,021
ZMA15/33	0,08	M15×1	33	16	4	2	28	8	M5	3	106 000	30	10	0,14
ZM17	0,028	M17×1	28	10	4	2	23	5	M5	3	57 000	30	15	0,401
ZM20	0,035	M20×1	32	10	4	2	27	5	M5	3	69 000	40	18	0,068
ZMA20/38	0,12	M20×1	38	20	5	2	33	10	M5	3	174 000	40	18	0,297
ZMA20/52	0,32	M20×1	52	25	5	2	47	12,5	M5	3	218 000	40	18	1,38
ZM25	0,055	M25×1,5	38	12	5	2	33	6	M6	5	90 000	60	25	0,157
ZMA25/45	0,16	M25×1,5	45	20	5	2	40	10	M6	5	211 000	60	25	0,572
ZMA25/58	0,43	M25×1,5	58	28	6	2,5	52	14	M6	5	305 000	60	25	2,36
ZM30	0,075	M30×1,5	45	12	5	2	40	6	M6	5	112 000	70	32	0,304
ZMA30/52	0,22	M30×1,5	52	22	5	2	47	11	M6	5	270 000	70	32	1,1
ZMA30/65	0,55	M30×1,5	65	30	6	2,5	59	15	M6	5	390 000	70	32	3,94
ZM35	0,099	M35×1,5	52	12	5	2	47	6	M6	5	134 000	80	40	0,537
ZMA35/58	0,26	M35×1,5	58	22	6	2,5	52	11	M6	5	300 000	80	40	1,66
ZMA35/70	0,61	M35×1,5	70	30	6	2,5	64	15	M6	5	460 000	80	40	5,2
ZM40	0,14	M40×1,5	58	14	6	2,5	52	7	M6	5	157 000	95	55	0,945
ZMA40/62	0,27	M40×1,5	62	22	6	2,5	56	11	M8	15	310 000	95	55	2,07
ZMA40/75	0,67	M40×1,5	75	30	6	2,5	69	15	M8	15	520 000	95	55	6,72
ZM45	0,17	M45×1,5	65	14	6	2,5	59	7	M6	5	181 000	110	65	1,48
ZMA45/68	0,35	M45×1,5	68	24	6	2,5	62	12	M8	15	360 000	110	65	3,2
ZMA45/85	0,92	M45×1,5	85	32	7	3	78	16	M8	15	630 000	110	65	11,9
ZM50	0,19	M50×1,5	70	14	6	2,5	64	7	M6	5	205 000	130	85	1,92
ZMA50/75	0,43	M50×1,5	75	25	6	2,5	68	12,5	M8	15	415 000	130	85	4,89
ZMA50/92	1,06	M50×1,5	92	32	8	3,5	84	16	M8	15	680 000	130	85	16,1
ZM55	0,23	M55×2	75	16	7	3	68	8	M6	5	229 000	150	95	2,77
ZMA55/98	1,17	M55×2	98	32	8	3,5	90	16	M8	15	620 000	150	95	20,5

1) When clamped, the grub screw protrudes by ≈ 0,5 mm.



Precision locknuts

For radial locking

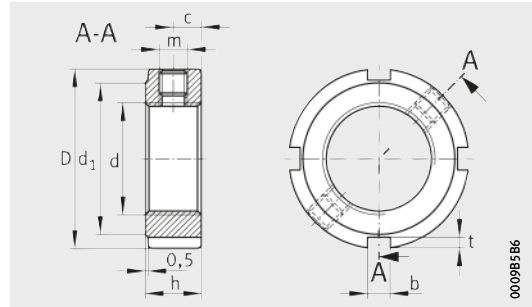

ZM, ZMA

Dimension table (continued) · Dimensions in mm

Designation	Mass m ≈ kg	Dimensions									Grub screw Tightening torque M _A Nm	Locknut			
		d	D	h	b	t	d ₁	c	m	F _{aB} N		M _L at M _{AL} Nm	Reference tightening torque Nm	Mass moment of inertia M _M kg · cm ²	
ZM60	0,25	M60×2	80	16	7	3	73	8	M6	5	255 000	180	100	3,45	
ZMA60/98	1,07	M60×2	98	32	8	3,5	90	16	M8	15	680 000	180	100	19,6	
ZM65	0,27	M65×2	85	16	7	3	78	8	M6	5	280 000	200	120	4,24	
ZMA65/105	1,21	M65×2	105	32	8	3,5	97	16	M8	15	750 000	200	120	25,6	
ZM70	0,36	M70×2	92	18	8	3,5	85	9	M8	15	305 000	220	130	6,61	
ZMA70/110	1,4	M70×2	110	35	8	3,5	102	17,5	M8	15	810 000	220	130	33	
ZM75	0,4	M75×2	98	18	8	3,5	90	9	M8	15	331 000	260	150	8,41	
ZMA75/125	2,11	M75×2	125	38	8	3,5	117	19	M8	15	880 000	260	150	62,2	
ZM80	0,46	M80×2	105	18	8	3,5	95	9	M8	15	355 000	285	160	11,2	
ZMA80/120	1,33	M80×2	120	35	8	4	105	17,5	M8	15	810 000	285	160	44,6	
ZM85	0,49	M85×2	110	18	8	3,5	102	9	M8	15	385 000	320	190	13,1	
ZM90	0,7	M90×2	120	20	10	4	108	10	M8	15	410 000	360	200	21,8	
ZMA90/130	2,01	M90×2	130	38	10	4	120	19	M8	15	910 000	360	200	64,1	
ZMA90/155	3,36	M90×2	155	38	10	4	146	19	M8	15	1 080 000	360	200	150	
ZM100	0,77	M100×2	130	20	10	4	120	10	M8	15	465 000	425	250	28,6	
ZMA100/140	2,23	M100×2	140	38	12	5	128	19	M10	20	940 000	425	250	82,8	
ZM105	1,05	M105×2	140	22	12	5	126	11	M10	20	495 000	475	300	44,5	
ZM110	1,09	M110×2	145	22	12	5	133	11	M10	20	520 000	510	350	50,1	
ZM115	1,13	M115×2	150	22	12	5	137	11	M10	20	550 000	550	400	56,2	
ZM120	1,28	M120×2	155	24	12	5	138	12	M10	20	580 000	600	450	68,4	
ZM125	1,33	M125×2	160	24	12	5	148	12	M10	20	610 000	640	500	76,1	
ZM130	1,36	M130×2	165	24	12	5	149	12	M10	20	630 000	700	550	84,3	
ZM140	1,85	M140×2	180	26	14	6	160	13	M12	38	690 000	800	600	133	
ZM150	2,24	M150×2	195	26	14	6	171	13	M12	38	750 000	900	650	188	

Sockets

For precision locknuts
suitable for axial locking

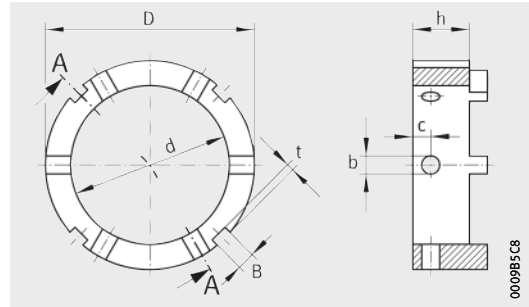

AMS

Dimension table · Dimensions in mm

Designation	Mass m ≈ kg	Dimensions							For precision locknuts
		d	D	h	b H11	c	B	t	
AMS20	0,047	22	32	14	4	5	4	2	AM15, AM17, AM20
AMS30	0,093	35	45	15	5	5	5	2	AM25, AM30, AM35/58, AM30/65
AMS40	0,217	45	65	16	6	6	6	2,5	AM35, AM40
AMS50	0,245	53	70	19	6	6	6	2,5	AM45, AM50
AMS60	0,37	65	85	20	6	6	7	3	AM55, AM60
AMS70	0,615	75	98	25	8	10	8	3,5	AM65, AM70
AMS80	0,755	85	110	25	8	10	8	3,5	AM75, AM80, AM85
AMS90	1,215	95	130	25	8	10	10	4	AM90
AMS110	0,74	110	130	25	8	10	10	4	AM100, AM110
AMS130	1,485	130	155	25	8	10	12	5	AM120, AM130



Sockets

For precision locknuts
 suitable for radial or axial locking
 For torque wrench
 Suitable for combination with sockets AMS

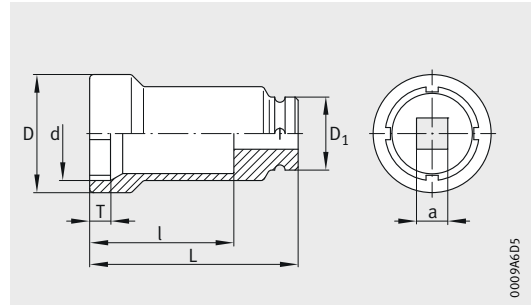

LOCKNUT-SOCKET-KM

Dimension table - Dimensions in mm											
Designation	Mass ≈ kg	Dimensions							Suitable for		Suitable in combination with AMS for AM
		d	D	D ₁	L	l	T	a inch	Precision locknut	Socket	
									ZM	AMS	
LOCKNUT-SOCKET-KM0	0,1	18,1	22	22	57	44	5	3/8	ZM10	-	-
LOCKNUT-SOCKET-KM1	0,1	22,2	28	22	57	44	5	3/8	ZM12	-	-
LOCKNUT-SOCKET-KM2	0,2	25,2	33	30	82	60	6	1/2	ZM15	-	-
LOCKNUT-SOCKET-KM3	0,24	28,2	36	30	82	60	6	1/2	ZM17	-	-
LOCKNUT-SOCKET-KM4	0,28	32,2	38	30	82	56	9	1/2	ZM20	AMS20	AM15 AM17 AM20
LOCKNUT-SOCKET-KM5	0,38	38,2	46	30	82	56	9	1/2	ZMA20/38 ZM25	-	-
LOCKNUT-SOCKET-KM6	0,42	45,2	53	30	82	56	9	1/2	ZMA25/45 ZM30 - -	AMS30	AM25 AM30 AM35/58 AM30/65
LOCKNUT-SOCKET-KM7	0,45	52,2	60	30	82	56	9	1/2	ZMA20/52 ZMA30/52 ZM35	-	-
LOCKNUT-SOCKET-KM8	0,61	58,3	68	30	82	56	9	1/2	ZMA25/58 ZMA35/58 ZM40	-	-
LOCKNUT-SOCKET-KM9	0,8	65,4	73,5	44	90	62	13,5	3/4	ZMA30/65 - - ZM45	AMS40	AM35 AM40
LOCKNUT-SOCKET-KM10	0,85	70,4	78,5	44	90	62	135	3/4	ZMA35/70 - ZM50	AMS50	AM45 AM50
LOCKNUT-SOCKET-KM11	0,9	75,4	83,5	44	90	62	13,5	3/4	ZMA40/75 ZMA50/75 ZM55	-	-

Sockets

For precision locknuts
 suitable for radial or axial locking
 For torque wrench
 Suitable for combination with sockets AMS

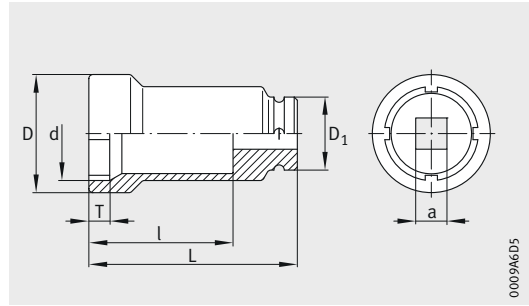

LOCKNUT-SOCKET-KM

0009A6D5

Dimension table (continued) - Dimensions in mm												
Designation	Mass ≈ kg	Dimensions							Suitable for		Suitable in combination with AMS for AM	
		d	D	D ₁	L	l	T	a inch	Precision locknut ZM	Socket AMS		
LOCKNUT-SOCKET-KM13	1,1	85,6	94	44	90	60	13,5	3/4	ZMA45/85	–	–	
									–	AMS60	AM55	
									–	–	AM60	
LOCKNUT-SOCKET-KM14	2,2	92,5	103	76	110	74	12	1	ZMA50/92	–	–	
									ZM70	–	–	
LOCKNUT-SOCKET-KM15	2,3	98,5	109	76	110	74	13	1	ZMA55/98	–	–	
									ZMA60/98	–	–	
									–	AMS70	AM65	
									–	–	AM70	
LOCKNUT-SOCKET-KM16	2,45	105,6	116	76	110	74	15	1	ZMA65/105	–	–	
									ZM80	–	–	
LOCKNUT-SOCKET-KM17	2,6	110,6	121	76	110	74	16	1	ZMA70/110	–	–	
									–	AMS80	AM75	
									–	–	AM80	
									ZM85	–	AM85	
LOCKNUT-SOCKET-KM18	2,9	120,6	131	76	110	74	16	1	ZMA80/120	–	–	
									ZM90	–	–	
LOCKNUT-SOCKET-KM19	3,05	125,6	137	76	110	74	17	1	ZMA75/125	–	–	
LOCKNUT-SOCKET-KM20	3,3	130,6	143	76	110	74	18	1	ZMA90/130	AMS90	AM90	
									ZM100	AMS110	AM100	
									–	–	AM110	
LOCKNUT-SOCKET-KM21	3,43	115	153	76	110	80	18	1	ZMA100/140	–	–	
									ZM105	–	–	
LOCKNUT-SOCKET-KM22	3,54	120	158	76	110	80	18	1	ZM110	–	–	
									ZMA90/155	–	–	
LOCKNUT-SOCKET-KM24	4,15	130	170	76	110	80	18	1	ZM120	AMS130	AM120	
									–	–	AM130	
									–	–	–	



BEARINX-online Easy BallScrew

Calculation of screw drive bearing arrangements

In order to ensure the correct use of products, Schaeffler offers the necessary support in partnership with the customer, from the very first design idea to delivery of the products. A key aspect of design advisory work is the selection and design of rolling bearings. The optimum selection and design of products gives Schaeffler customers a competitive advantage. To this end, Schaeffler has been successfully using calculation programs for many years.

BEARINX-online

Through the use of BEARINX, specific bearing loads can be calculated in detail, represented and documented taking account of operating and environmental conditions. The contact pressure on each individual rolling element is included in the calculation process.

BEARINX takes account of factors including the following:

- the non-linear elastic deflection behaviour of rolling elements
- elasticity of the bearing rings
- displacements in contact angle induced by load
- the actual contact pressure taking account of the misalignment and profiling of rolling elements.

Module Easy BallScrew

For the calculation of screw drive bearing arrangements, there is a separate BEARINX-online module which can be used to calculate the most commonly used arrangements of bearings, *Figure 1*.

In addition to the existing BEARINX-online software, the new module Easy BallScrew fits logically into the proven range of Easy calculation programs.

With Easy BallScrew, it is possible to calculate the minimum static load safety factor and the adjusted reference rating life for all arrangements of bearings. For locating/locating bearing arrangements, the spindle tensioning force and the value for effective spindle elongation due to tensioning as well as all adjustment values for mounting are also outputted.

Easy BallScrew has access to the Schaeffler bearing database. Axial angular contact ball bearings and needle roller/axial cylindrical roller bearings as well as other screw drive bearings can be easily integrated.



Figure 1
BEARINX-online,
module Easy BallScrew

Influencing factors typical for the application

The following influencing factors typical for the application are taken into consideration:

- location of the bearing on the shaft
- consideration of shaft material
- consideration of bearing set combinations
- operating temperature range
- lubrication and severity of contamination.

User-friendly interface

The program provides four common arrangements of bearings for screw drives as preconfigured calculation models, *Figure 2*:

- locating bearing arrangement on one side
- locating/non-locating bearing arrangement
- locating/locating bearing arrangement (spindle tensioning by locknut)
- locating/locating bearing arrangement (spindle tensioning by shim).

All the necessary operating data can be inputted separately, with navigation by means of user-friendly menus:

- arrangement of bearings
- bearing selection
- load case data
- lubrication.

Data can be inputted quickly and easily thanks to the self-explanatory menu navigation, *Figure 3*, page 156. The geometrical data of INA and FAG rolling bearings are easily loaded from an integrated database. Operating conditions are inputted in the form of a duty cycle in a table, *Figure 4*, page 156.

- ① Locating bearing arrangement, one side
- ② Locating/non-locating bearing arrangement
- ③ Locating/locating bearing arrangement (spindle tensioning by locknut)
- ④ Locating/locating bearing arrangement (spindle tensioning by shim)

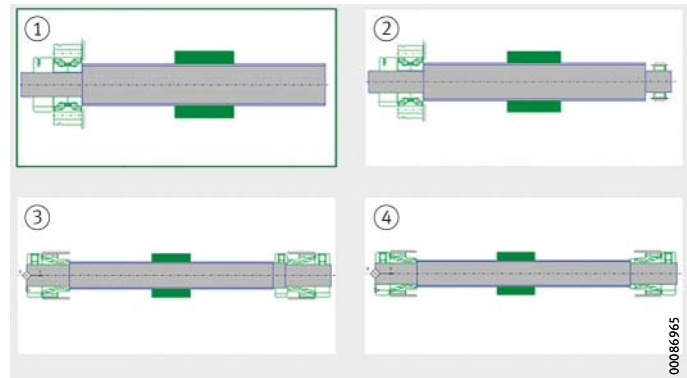

Figure 2
Preconfigured calculation models



BEARINX-online Easy BallScrew

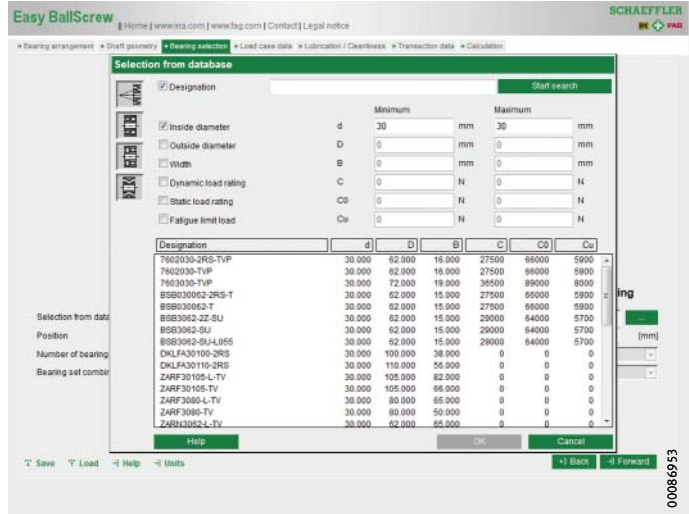

Figure 3
Bearing selection from database

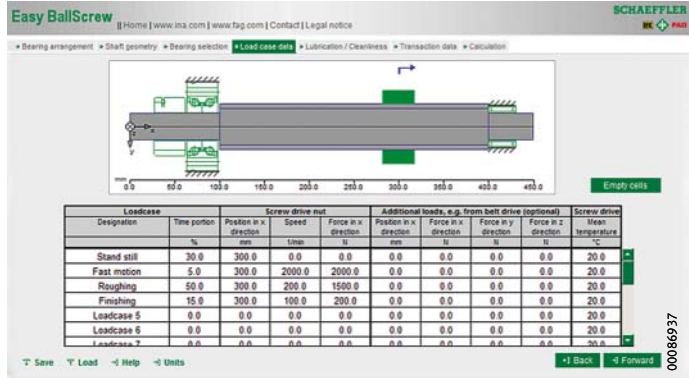

Figure 4
Input of speed/load cycle

Data interchange with Schaeffler

All input data can be stored. As a result, relevant modifications can be quickly made to an existing application case without the need for duplicated input of data. Furthermore, the stored file can be exchanged with the Schaeffler engineering service in order to achieve an optimum bearing design.

The BEARINX-online modules run on the powerful calculation servers at Schaeffler. Once calculation has been successfully carried out, the most significant calculation results are displayed. In addition, a comprehensive results view can be called up.

Registration for the calculation program

<http://bearinx-online-easy-ballscrew.schaeffler.com>



The module BEARINX-online Easy BallScrew is available only in an online format and can be used free of charge.

Initial registration takes only a short time and you can then start your calculation work straight away.

Addresses

Worldwide

You can find all the addresses and contacts for Schaeffler at www.schaeffler.com

Argentina

Schaeffler Argentina S.r.l.
Av. Alvarez Jonte 1938
C1416EXR Buenos Aires
Tel. +(54) 11 / 40 16 15 00
Fax +(54) 11 / 45 82 33 20
info-ar@schaeffler.com

Armenia

Schaeffler Ukraine GmbH
Zhylyanskaya Str. 75, 5. Stock,
Businesscenter «Eurasia»
01032 Kiev
Ukraine
Tel. +(380) 44 520 13 80
Fax +(380) 44 520 13 81
info.ua@schaeffler.com

Australia

Schaeffler Australia Pty Ltd
Level 1, Bldg 8, Forest Central
Business Park
49 Frenchs Forest Road
Frenchs Forst, NSW 2086
Tel. +(61) 2 8977 1000
Fax +(61) 2 9452 4242
sales.au@schaeffler.com

Schaeffler Australia Pty Limited
Suite 14, Level 3
74 Doncaster Road
North Balwyn, VIC 3104
Tel. +(61) 3 9859 8020
Fax +(61) 3 9859 8767
milos.grujic@schaeffler.com

Schaeffler Australia Pty Ltd
Unit 3, 47 Steel Place
Morningside, QLD 4170
Tel. +(61) 7 3399 9161
Fax +(61) 7 3399 9351
martin.grosvenor@schaeffler.com

Austria

Schaeffler Austria GmbH
Ferdinand-Pözl-Straße 2
2560 Berndorf-St. Veit
Tel. +(43) 2672 202-0
Fax +(43) 2672 202-1003
info.at@schaeffler.com

Belarus

Schaeffler Technologies AG & Co. KG
Repräsentanz Weißrussland
Odoewskogo 117, office 317
220015 Minsk
Tel. +(375) 17 336 94 81
Fax +(375) 17 336 94 82
info.by@schaeffler.com

Belgium

Schaeffler Belgium S.P.R.L./B.V.B.A.
Avenue du Commerce, 38
1420 Braine L'Alleud
Tel. +(32) 2 3 89 13 89
Fax +(32) 2 3 89 13 99
info.be@schaeffler.com

Bolivia

Schaeffler Chile Ltda.
Jose Tomas Rider 1051
Providencia
7501037 Santiago
Chile
Tel. +(56) 2 477 5000
Fax +(56) 2 2223 9941
info-cl@schaeffler.com

Bosnia-Herzegovina

Schaeffler Hrvatska d.o.o.
Ogrizovićeva 28b
10000 Zagreb
Croatia
Tel. +(385) 1 37 01 943
Fax +(385) 1 37 64 473
info.hr@schaeffler.com

Brazil

Schaeffler Brasil Ltda.
Av. Independência, 3500-A
Bairro Eden
18087-101 Sorocaba, SP
Tel. +(55) 15 3335 1422
Tel. 0800 11 10 29
Fax +(55) 1533 35 19 60
sac.br@schaeffler.com

Bulgaria

Schaeffler Bulgaria OOD
Dondukov-Blvd. No 62
Eing. A, 6. Etage, App. 10
1504 Sofia
Tel. +(359) 2 946 3900
+(359) 2 943 4008
Fax +(359) 2 943 4134
info.bg@schaeffler.com

Canada

Schaeffler Canada Inc.
100 Alexis Nihon Suite 390
Montréal, QC H4M 2N8
Tel. +(1) 514-748-5111
Tel. 800-361-5841 Toll Free
Fax +(1) 514-748-6111
info.ca@schaeffler.com

Schaeffler Canada Inc.
2871 Plymouth Drive
Oakville, ON L6H 5S5
Tel. +(1) 905-829-2750
Tel. 800-263-4397 Toll Free
Fax +(1) 905-829-2563
info.ca@schaeffler.com

Schaeffler Canada Inc.
#106, 7611 Sparrow Drive
Leduc, AB T9E 0H3
Tel. +(1) 780-980-3016
Tel. 800-663-9006 Toll Free
Fax +(1) 780-980-3037
info.ca@schaeffler.com

Chile

Schaeffler Chile Ltda.
Jose Tomas Rider 1051
Providencia
7501037 Santiago
Chile
Tel. +(56) 2 477 5000
Fax +(56) 2 2223 9941
info-cl@schaeffler.com

China

Schaeffler Holding (China) Co., Ltd.
No. 1 Antuo Road
(west side of Anhong Road)
AnTing, JiaDing District
201804 Shanghai
Tel. +(86) 21 3957 6666
Fax +(86) 21 3957 6600
info_china@schaeffler.com

Colombia

Schaeffler Colômbia Ltda.
Cra. 10 N° 97A 13 Torre A
Ofic 209 Bogotá Trade Center
Bogotá
Tel. +(57) 1 621 53 00
Fax +(57) 1 621 03 22
info-co@schaeffler.com

Addresses

Croatia

Schaeffler Hrvatska d.o.o.
Ogrizovićeva 28b
10000 Zagreb
Tel. +(385) 1 37 01 943
Fax +(385) 1 37 64 473
info.hr@schaeffler.com

Czech Republic

Schaeffler CZ s.r.o.
Průběžná 74a
100 00 Praha 10
Tel. +(420) 267 298 111
Fax +(420) 267 298 110
info.cz@schaeffler.com

Denmark

Schaeffler Danmark ApS
Jens Baggesens Vej 90P
8200 Aarhus N
Tel. +(45) 70 15 44 44
Fax +(45) 70 15 22 02
info.dk@schaeffler.com

Egypt

Delegation Office
Schaeffler Technologies
25, El Obour Buildings – Floor 18 – Flat 4
Salah Salem St.
11371 Cairo
Tel. +(20) 2 24012432
Fax +(20) 2 22612637
schaeffleregypt@schaeffleregypt.com

Estonia

Schaeffler Technologies
Repräsentanz Baltikum
Duntes iela 23a
1005 Riga
Latvia
Tel. +(371) 67 06 37 95
Fax +(371) 67 06 37 96
info.lv@schaeffler.com

Finland

Schaeffler Finland Oy
Lautamiehentie 3
02770 Espoo
Tel. +(358) 207 36 6204
Fax +(358) 207 36 6205
info.fi@schaeffler.com

France

Schaeffler France SAS
93, route de Bitche, BP 30186
67506 Haguenau
Tel. +(33) 3 88 63 40 40
Fax +(33) 3 88 63 40 41
info.fr@schaeffler.com

Germany

Schaeffler Technologies AG & Co. KG
Industriestraße 1 – 3
91074 Herzogenaurach
Tel. +(49) 9132 82-0
Fax +(49) 9132 82-4950
info.de@schaeffler.com

Schaeffler Technologies AG & Co. KG
Georg-Schäfer-Str. 30
97421 Schweinfurt
Tel. +(49) (9721) 91-0
Fax +(49) (9721) 91-3435
faginfo@schaeffler.com

FAG Aerospace GmbH & Co. KG
Georg-Schäfer-Str. 30
97421 Schweinfurt
Tel. +49 (0 97 21) 91-33 72
astrid.hofmann@schaeffler.com

Hungary

Schaeffler Magyarország Ipari Kft.
Rétköz u.5
1118 Budapest
Tel. +(36) 1 4 81 30 50
Fax +(36) 1 4 81 30 53
budapest@schaeffler.com

India

FAG Bearings India Limited
Maneja
Vadodara 390 013
Tel. +(91) 26 52 6426-51
Fax +(91) 26 52 6388-04/-10
info.fag.in@schaeffler.com

Italy

Schaeffler Italia S.r.l.
Via Dr. Georg Schaeffler, 7
28015 Momo (Novara)
Tel. +(39) 3 21 92 92 11
Fax +(39) 3 21 92 93 00
info.it@schaeffler.com

Japan

Schaeffler Japan Co., Ltd.
Schaeffler R&D Center Building,
Yokohama Business Park,
134 Godo-cho, Hodogaya-ku,
240-0005 Yokohama
Tel. +(81) 45 287 9001
Fax +(81) 45 287 9011
info-japan@schaeffler.com

Korea

Schaeffler Korea Corporation –
Guro Office
A-501, 1258, Guro-dong, Guro-gu,
Seoul, 152-721
Tel. +(82) 2 2625-8572
Fax +(82) 2 2611-6075

Latvia

Schaeffler Technologies
Repräsentanz Baltikum
Duntes iela 23a
1005 Riga
Tel. +(371) 7 06 37 95
Fax +(371) 7 06 37 96
info.lv@schaeffler.com

Lithuania

Schaeffler Technologies
Repräsentanz Baltikum
Duntes iela 23a
1005 Riga
Latvia
Tel. +(371) 7 06 37 95
Fax +(371) 7 06 37 96
info.lv@schaeffler.com

Luxembourg

Schaeffler Belgium S.P.R.L./B.V.B.A.
Avenue du Commerce, 38
1420 Braine L'Alleud
Belgium
Tel. +(32) 2 3 89 13 89
Fax +(32) 2 3 89 13 99
info.be@schaeffler.com

Malaysia

Schaeffler Bearings (Malaysia) Sdn. Bhd.
5-2 Wisma Fiamma, No. 20 Jalan 7A/62A
Bandar Menjalara
52200 Kuala Lumpur
Tel. +(60) 3-6275 0620
Fax +(60) 3 6275 6421
marketing_my@schaeffler.com

Schaeffler Bearings (Malaysia) Sdn. Bhd.
(Penang Branch)
No. B-02-28, 2nd Floor, Krystal Point
303, Jalan Sultan Azlan Shah
11900 Sungai Nibong
Tel. +(60) 4 642 3708/3781
Fax +(60) 4 642 3724

Mexico

INA México, S.A. de C.V. -
Rodamientos FAG, S.A. de C.V.
Henry Ford #141
Col. Bondojito
Deleg. Gustavo A. Madero
07850 Mexico D.F.
Tel. +(52) 55 5062 6085
Fax +(52) 55 5739 5850
distr.indl.mx@schaeffler.com

Netherlands

Schaeffler Nederland B.V.
Gildeweg 31
3771 NB Barneveld
Tel. +(31) 342 40 30 00
Fax +(31) 342 40 32 80
info.nl@schaeffler.com

New Zealand

Schaeffler New Zealand
(Unit R, Cain Commercial Centre)
20 Cain Road
1135 Penrose
Tel. +(64) 9 583 1280
Fax +(64) 9 583 1288
sales.nz@schaeffler.com

Norway

Schaeffler Norge AS
Grenseveien 107B
0663 Oslo
Tel. +(47) 23 24 93 30
Fax +(47) 23 24 93 31
info.no@schaeffler.com

Philippines

Schaeffler Philippines Inc
5th Floor, Optima Building
221 Saicedo Street, Legaspi Village
1229 Makati City
Tel. +(63) 2 759 3583
Fax +(63) 2 779 8703
marketing_ph@schaeffler.com

Poland

Schaeffler Polska Sp. z o.o.
Budynek E
ul. Szyszkowa 35/37
02-285 Warszawa
Tel. +(48) 22 8 78 41 20
Fax +(48) 22 8 78 41 22
info.pl@schaeffler.com

Portugal

INA Rolamentos Lda.
Arrábida Lake Towers
Rua Daciano Baptista Marques Torre C,
181, 2º piso
4400-617 Vila Nova de Gaia
Tel. +(351) 22 5 32 08 00
Fax +(351) 22 5 32 08 60
info.pt@schaeffler.com

Schaeffler Portugal S.A.
Rua Estrada do Lavradio 25
2500-294 Caldas da Rainha
Tel. +(351) 262 837000
Fax +(351) 262 837011

Romania

S.C. Schaeffler Romania S.R.L.
Aleea Schaeffler Nr. 3
507055 Cristian/Brasov
Tel. +(40) 268 504816
Fax +(40) 268 505848
info.ro@schaeffler.com

Russia

Schaeffler Russland GmbH
Leningradsky Prospekt 47, Bau 3
Business-Center Avion
125167 Moscow
Tel. +(7) 495 7 37 76 60
Fax +(7) 495 7 37 76 61
info.ru@schaeffler.com

Saudi Arabia

Schaeffler Middle East FZE
Road SE101, Schaeffler Building
Jebel Ali Free Zone – Southside
Postbox 261808
Dubai UAE
United Arab Emirates
Tel. +(971) 4 81 44 500
Fax +(971) 4 81 44 601
info.ae@schaeffler.com

Serbia

Schaeffler Technologies
Repräsentanz Serbien
Branka Krsmanovica 12
11118 Beograd
Tel. +(381) 11 308 87 82
Fax +(381) 11 308 87 75
fagbgdyu@orion.rs

Singapore

Schaeffler (Singapore) Pte. Ltd.
151 Lorong Chuan, #06-01
New Tech Park, Lobby A
556741 Singapore
Tel. +(65) 6540 8600
Fax +(65) 6540 8668
info.sg@schaeffler.com

Slovak Republic

Schaeffler Slovensko, spol. s r.o.
Ulica Dr. G. Schaefflera 1
02401 Kysucké Nové Mesto
Tel. +(421) 41 4 20 51 11
Fax +(421) 41 4 20 59 18
info.sk@schaeffler.com

Schaeffler Slovensko, spol. s r.o.
Nevádzova 5
821 01 Bratislava
Tel. +(421) 2 43 294 260
Fax +(421) 2 48 287 820
info.sk@schaeffler.com

Slovenia

Schaeffler Slovenija d.o.o.
Glavni trg 17/b
2000 Maribor
Tel. +(386) 2 22 82 070
Fax +(386) 2 22 82 075
info@schaeffler.si

South Africa

Schaeffler South Africa (Pty.) Ltd.
1 End Street Ext. Corner Heidelberg Road
2000 Johannesburg
Tel. +(27) 11 225 3000
Fax +(27) 11 334 1755
info.co.za@schaeffler.com

Spain

Schaeffler Iberia, S.L.U. –
División Industria
C/ Foment, 2
Polígono Ind. Pont Reixat
08960 Sant Just Desvern – Barcelona
Tel. +(34) 93 4 80 34 10
Fax +(34) 93 3 72 92 50
info.es@schaeffler.com

Sweden

Schaeffler Sverige AB
Charles gata 10
195 61 Arlandastad
Tel. +(46) 8 59 51 09 00
Fax +(46) 8 59 51 09 60
info.se@schaeffler.com

Switzerland

Schaeffler Schweiz GmbH
Badstrasse 14
8590 Romanshorn
Tel. +(41) 71 4 66 66 66
Fax +(41) 71 4 66 63 33
info.ch@schaeffler.com

Taiwan

Schaeffler Taiwan Co. Ltd.
23F, No.76, Sec. 2, Dunhua S. Rd.,
Da'an Dist.
Taipei 106
Tel. +886 2 7730 1911
Fax +886 2 2707 9964
info.tw@schaeffler.com

Thailand

Schaeffler (Thailand) Co., Ltd.
388 Exchange Tower 31st, 34th Floor,
Unit 3103, 3403-3404 Sukhumvit Rd.,
Klongtoey
Bangkok, 10110
Tel. +(66) 2697 0000
Fax +(66) 2697 0001
info.th@schaeffler.com

Addresses

Turkey

Schaeffler Rulmanlari Ticaret Limited
Sirketi
Ömer Faik Atakan cad. Saray Mah. Yılmaz
Plaza No:3
34768 Istanbul
Tel. +(90) 212 2 79 27 41
Fax +(90) 212 2 81 66 45
info.tr@schaeffler.com

Ukraine

Schaeffler Ukraine GmbH
Zhylyanskaya Str. 75, 5. Stock,
Businesscenter «Eurasia»
01032 Kiev
Ukraine
Tel. +(380) 44 520 13 80
Fax +(380) 44 520 13 81
info.ua@schaeffler.com

United Kingdom

Schaeffler (UK) Ltd
Forge Lane, Minworth
Sutton Coldfield B76 1AP
Tel. +(44) 121 3 13 58 70
Fax +(44) 121 3 13 00 80
info.uk@schaeffler.com

The Barden Corporation (UK) Limited
Plymbridge Road, Estover
Plymouth, PL6 7LH
Tel. +(44) 1752 73 55 55
Fax +(44) 1752 73 34 81
bardenbearings@schaeffler.com

United Arab Emirates

Schaeffler Middle East FZE
Road SE101, Schaeffler Building
Jebel Ali Free Zone - Southside
Postbox 261808
Dubai UAE
Tel. +971 4 81 44 500
Fax +971 4 81 44 601
info.ae@schaeffler.com

USA

Schaeffler Group USA Inc.
200 Park Avenue
P.O. Box 1933
Danbury, CT 06813-1933
Tel. +(1) 203 790 5474
Fax +(1) 203 830 8171
Walter.Newton@schaeffler.com

The Barden Corporation
200 Park Avenue
P.O. Box 2449
Danbury, CT 06813-2449
Tel. +(1) 203 744 2211
Fax +(1) 203 744 3756
sales@bardenbearings.com

Schaeffler Group USA Inc.
308 Springhill Farm Road
Corporate Offices
Fort Mill, SC 29715
Tel. +(1) 803 548 8500
Fax +(1) 803 548 8599
info.us@schaeffler.com

Schaeffler Group USA Inc.
5370 Wegman Drive
Valley City, OH 44280-9700
Tel. +(1) 800 274 5001
Fax +(1) 330 273 3522
luk-ina-fag-as.us@schaeffler.com

Venezuela

Schaeffler Venezuela C.A.
Urbanización San José de Tarbes
Torre BOD, Piso 14, Oficina 14-1
Valencia
Tel. +(58) 58 241 825 9250
Fax +(58) 58 241 825 9705
ana.acevedo@schaeffler.com

Vietnam

Schaeffler Vietnam Co., Ltd –
Ho Chi Minh Sales Office
6th Floor, TMS Building,
172 Hai Ba Trung street, Da Kao Ward,
District 1.
Ho Chi Minh City
Tel. +(84) 8 22 20 2777
Fax +(84) 8 22 20 2776
marketing_vn@schaeffler.com

Schaeffler Vietnam Co., Ltd –
Hanoi Sales Office
MIPEC Tower, 12th Floor No. 229
Tay Son Street, Dong Da District
Ha Noi
Tel. +(84) 4 3556 0930
Fax +(84) 4 3556 0931
marketing_vn@schaeffler.com



**Schaeffler Technologies
AG & Co. KG**

Industriestraße 1 – 3
91074 Herzogenaurach
Germany
Internet www.ina.com
E-mail info.de@schaeffler.com

In Germany:

Phone 0180 5003872
Fax 0180 5003873

From other countries:

Phone +49 9132 82-0
Fax +49 9132 82-4950



**Schaeffler Technologies
AG & Co. KG**

Georg-Schäfer-Straße 30
97421 Schweinfurt
Germany
Internet www.fag.com
E-mail faginfo@schaeffler.com

In Germany:

Phone 0180 5003872
Fax 0180 5003873

From other countries:

Phone +49 9721 91-0
Fax +49 9721 91-3435

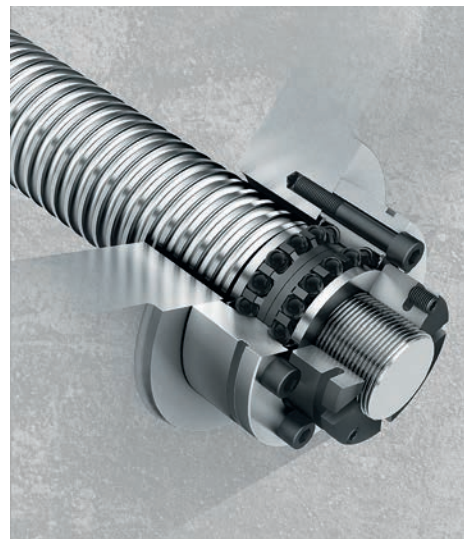

Every care has been taken to ensure the correctness of the information contained in this publication but no liability can be accepted for any errors or omissions. We reserve the right to make technical changes.

© Schaeffler Technologies AG & Co. KG
Issued: 2018, März

This publication or parts thereof may not be reproduced without our permission.